



Digital Protection & Measurement Device

Digital Protection & Measurement Device

LSIS protection and measurement products specializes in the protection and monitoring of electricity distribution networks, making your power distribution easier and more reliable. You can either integrate these products into your intelligent switchgear or use them as stand-alone multifunction units. In addition, all of these products provide versatile communications as well as sophisticated functionality for event, alarm and fault analysis.

The whole GIPAM, GIMAC product family for line, motor, generator protection and monitoring offers you an integrated solution which starts with extensive protection, measurement and control functionality.



GIPAM2000 FI



Contents

X GIPAM	N1
GIPAM-2000	N2
GIPAM-115	N3
DPR-1000	N4
IMC-IIIa	N5
GIMAC-V	O1
GIMAC-PQ	O2
GIMAC-IV	O3
GIMAC-II plus	O4
GIMAC-i	O5
GIMAC-DC	O6



Digital Protection device

		X-GIPAM					GIPAM-2000			GIPAM-115FI	DPR-1000
		F	B	M	T	DG	FI	T	M		
PROTECTION	Phase time overcurrent (51)	●	●	●	●	●	●	●	●	●	●
	Ground time overcurrent (51N/G)	●	●	●	●	●	●	●	●	●	●
	Phase instantaneous overcurrent (50)	●	●	●	●	●	●	●	●	●	●
	Ground instantaneous overcurrent (50N/G)	●	●	●	●	●	●	●	●	●	●
	Overcurrent Hiset & lowset (50,51H/L)	●	●	●	●	●	●	●	●	-	●(51)
	Negative sequence time overcurrent (46)	-	●	●	-	●	-	-	●	-	●
	Negative sequence overvoltage (47)	●	●	●	-	●	●	-	-	●	(POR)
	Thermal overload (49)	-	-	●	-	-	-	-	●	-	●
	Directional ground (67N)	●	●	●	-	●	●	-	●	-	●
	Sensitive ground (67G)	●	●	●	-	●	●	-	●	●	●
	Overvoltage ground (59N, 64)	●	●	●	-	●	●	-	-	●	-
	Undervoltage (27)	●	●	●	●	●	●	-	-	●	-
	Overvoltage (59)	●	●	●	●	●	●	-	-	●	-
	Stall/ Locked rotor (48/51LR)	-	-	●	-	-	-	-	●	-	●
	Undercurrent (37)	-	-	●	-	-	-	-	●	-	●
	Underfrequency (81U)	-	●	-	-	●	-	-	-	-	-
	Overfrequency (81O)	-	●	-	-	●	-	-	-	-	-
	Transformer phase differential (87T-P)	-	-	-	●	-	-	●	-	-	-
	Transformer ground differential (87T-G)	-	-	-	●	-	-	●	-	-	-
	Inrush Detector (68)	-	-	-	●	-	-	●	-	-	-
	Sync check (25)	●	●	-	-	●	-	-	-	-	-
	Forward/reverse active power (32P)	-	●	-	●	●	-	-	-	-	-
	Reverse reactive power (32Q)	-	●	-	-	●	-	-	-	-	-
Underpower (37P)	-	-	-	-	●	-	-	-	-	-	
Supervision of startingtime/Notching (66)	-	●	-	-	-	-	-	●	-	●	
Lock-out (86)	●	●	●	●	●	●	●	●	-	-	
Reclosing (79)	●	●	-	-	-	●	-	-	-	-	
Temperature (38)	●	●	●	●	-	-	-	-	-	●	
Setting Gr.	4					1			1		
I/O	Power outputs Point (Option)	4(+2x2)					4			2	
	Digital outputs Point (Option)	16(+6x2)					16			8	
	Digital inputs Point (Option)	20(+10x2)					20			3	
	Analog inputs/Output Channel (Option)	(+ AI/AO 6/4x2)					-			-	
MONITORING & METERING	Ia, Ib, Ic, In	●					●			●	
	Va, Vb, Vc, Vab, Vbc, Vca	●					●			●	
	Watts	●					●			●	
	Vars	●					●			●	
	kWh	●					●			●	
	kVarh	●					●			●	
	Frequency	●					●			●	
	Power factor	●					●			●	
	Trip circuit supervision	●					●			-	
	Trip relay supervision	●					●			-	
	VT fuse failure	●					-			-	
	CB operation failure	●					▲			●	
	Sag, Swell, Interruption	●					-			-	
	Harmonics, THD, TDD, K-Factor	63th, THD, TDD, K-Factor					13th, THD			-	
HMI	8.4" color touch LCD					320x240 Graphic LCD16x2 LCD			20x4 LCD		
Accuracy	I, V	±0.2%					±0.5%			±0.5%	
	W, Wh	±0.5%					±1.0%			±1.0%	
ADDITIONAL	Event recording	1000					800			128	
	Fault recording	200					200			32	
	Fault wave recording	128Cycle					Max. 512Cycle			-	
	Self-Test	●					-			-	
	Programmable logic	●					●			-	
	Mounting	Drow Out					Drow Out			Drow Out	
COMMUNICATION	PC Interface USB Port	1					-			-	
	PC Interface IrDA port	-					1			-	
	RS-485 (422) port	2					1			1	
	100/10 Base - T (TE)	2					1			-	
	100 Base - FX (FE)	2					1			-	
	I-NET (Custom LS)	-					●			●	
	Modbus	●					●			-	
	DNP3.0	●					●			-	
IEC61850 (TE)	●					-			-		

Digital Measurement device

		GIMAC-PQ	GIMAC-415	GIMAC-115 Plus	GIMAC-iEX	GIMAC-iNO
MONITORING & METERING	Ia, Ib, Ic, In	•	•	•	•	•
	Io, I1, I2	•	•	•	•	•
	Va, Vb, Vc, Vab, Vbc, Vca	•	•	•	•	•
	Vo, V1, V2	•	•	•	•	•
	Watts	•	•	•	•	•
	Vars	•	•	•	•	•
	VA	•	•	•	•	•
	kWh	•	•	•	•	•
	kVarh	•	•	•	•	•
	VAh				•	•
	Reverse Watts	•	•	•	•	•
	Reverse Vars	•	•	•	•	•
	Reverse VA	•	•	•	•	•
	Reverse kWh	•	•	•	•	•
	Reverse kVarh					•
	Frequency	•	•	•	•	•
	Power factor	•	•	•	•	•
	Phase	•	•	•	•	
	Unbalanced factor	•	•	•		
	Harmonics (V, I)	• (15th)	• (63th)	• (15th)	• (15th)	
	THD (V, I)	•	•	•	•	
	TDD (I)	•	•	•		
	k-factor	•	•	•		
Demand I	•	•	•	•		
Demand W	•	•	•	•		
CB operation	•	•	•			
CB operating time	•	•	•			
Accuracy	I, V W, Wh	±0.2% ±0.5%	±0.2% ±0.5%	±0.3% ±0.5%	±0.3% ±0.5%	±0.3% ±0.5%
I/O	Power outputs	2	2	2		
	Digital outputs	8	8	8		
	Digital inputs	10	10	10		
	Analog inputs	2	2			
ADDITIONAL	Power quality	•				
	Sag	•				
	Swell	•				
	Interruption	•				
	Undervoltage	•				
	Overvoltage	•				
	Auto power factor controller Option		•			
	Demand controller Option		•			
Event recording	256	300	256			
Fault wave recording	Max. 60cycle					
COMMUNICATION	RS-485 (422)	•	•	•	•	•
	I-NET (Custom LS)		•	•		
	Modbus	•	•	•	•	•
	Dual	•				

X GIPAM



neXt Generation Intelligent Device

XGIPAM is next generation intelligent device having IEC 61850, Setting Group, Power Quality, Arc Protection and function for control and Protection, monitoring that make possible to construct power protection and monitoring system



IEC 60255, KEMC 1120, IEC 61850
ISO 9001, ISO 14001



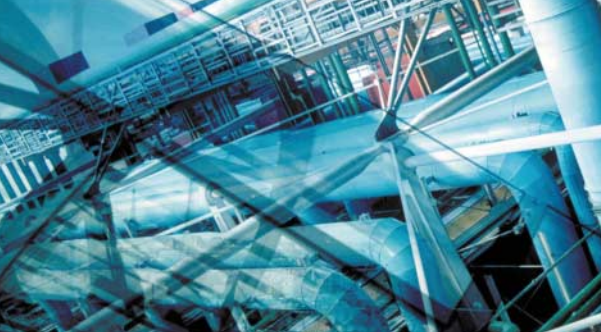

N₁



Contents :

Features	N-1-6
External & Structure	N-1-10
Functional Block Diagram	N-1-11
Technical Specifications	N-1-12
Rating	N-1-13
Characteristic	N-1-14
Wirings	N-1-19
Contact and Logic Usage	N-1-21
Dimension	N-1-23
Ordering	N-1-24
Certification	N-1-25





LSIS protection and measurement products specializes in the protection and monitoring of electricity distribution networks, making your power distribution easier and more reliable. You can either integrate these products into your intelligent switchgear or use them as standalone multifunction units. In addition, all of these products provide versatile communications as well as sophisticated functionality for event, alarm and fault analysis.

XGIPAM

neXt Generation Intelligent Device

Digital Integrated Protection
& Monitoring Device

neXt
Generation
HMI

neXt
Generation
Flexibility

neXt
Generation
Intelligent
Device

neXt
Generation
Application



The whole GIPAM, product family for line, motor, generator protection and monitoring offers you an integrated solution which starts with extensive protection, measurement and control functionality.

neXt Generation Intelligent Device

Features HMI

8.4" inches of large color Touch screen

- Convenient operation by 8.4" large color Touch screen
- Easy management by Graphic color LCD
- Intuitive display of various diagrams, pictures, charts
- Available to control and operate on screen by graphic user interface

Language selection and User selective menu

- Language selecting on X-GIPAM screen menu (Korean/English)
- Customizing frequent monitoring 3 menu

H/W, S/W flexibility

- Reliability Improvement by Independent module structure
- Expandable DI/DO boards (DI:32, DO:40 points)
- Expandable AI/AO boards (AI:12, AO:8 channels)
- 6 kinds of modular option
- Easy configuration and installation of switchboard by detachable HMI option

IEC 61850 communication

- Providing high-speed and two-way communication based on Ethernet
- Realization of wireless interlock by supplying GOOSE function
- Supporting all defined in IEC 61850 Standards (Report, Dataset, Control)
- Available to establish connection of communication system with different IEDs

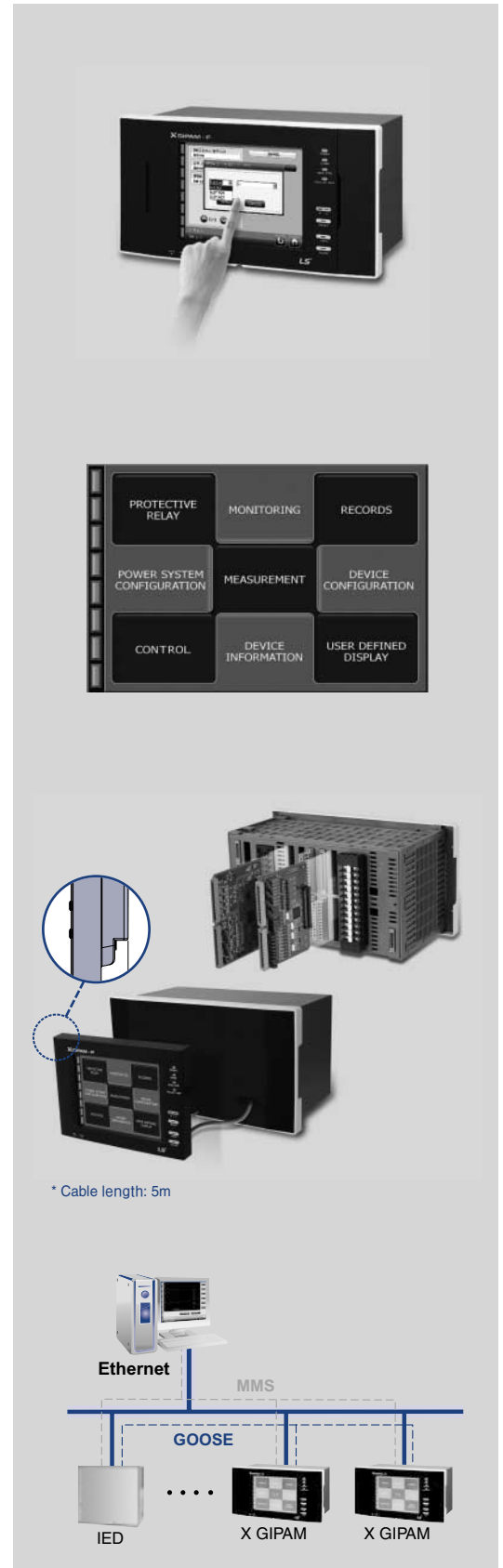

Hardware & software Flexibility

X-GIPAM manager with advanced function

- Available to set various menu through PC manager (relay elements, CB, CT/PT ratio, etc.)
- Setting and editing Digital or analog I/O points
- Measuring voltage, Frequency, Current ,power, Energy harmonics, etc.
- Analysis of Power quality, fault waveform (COMTRADE format)

Mimic Diagram function

- Convenient monitoring by graphic mimic diagram of power system on HMI
- Possible to check out status and control CB by touching the screen

Dual Communication System

- Supporting Independent dual communication system due to built-in dual ports
- Possible to communicate with multi-SCADA system without port switching
- Building a fail-safe communication system with Preliminary communication lines

Various measurements and monitoring functions

- 0.2% of Voltage and Current Measuring accuracy
- Graphical display of the load rate factor
- Recording peak/demand value of current and power
- Available to wave-capture for input voltage and current
- Easy to check wiring by VECTOR diagram in color LCD

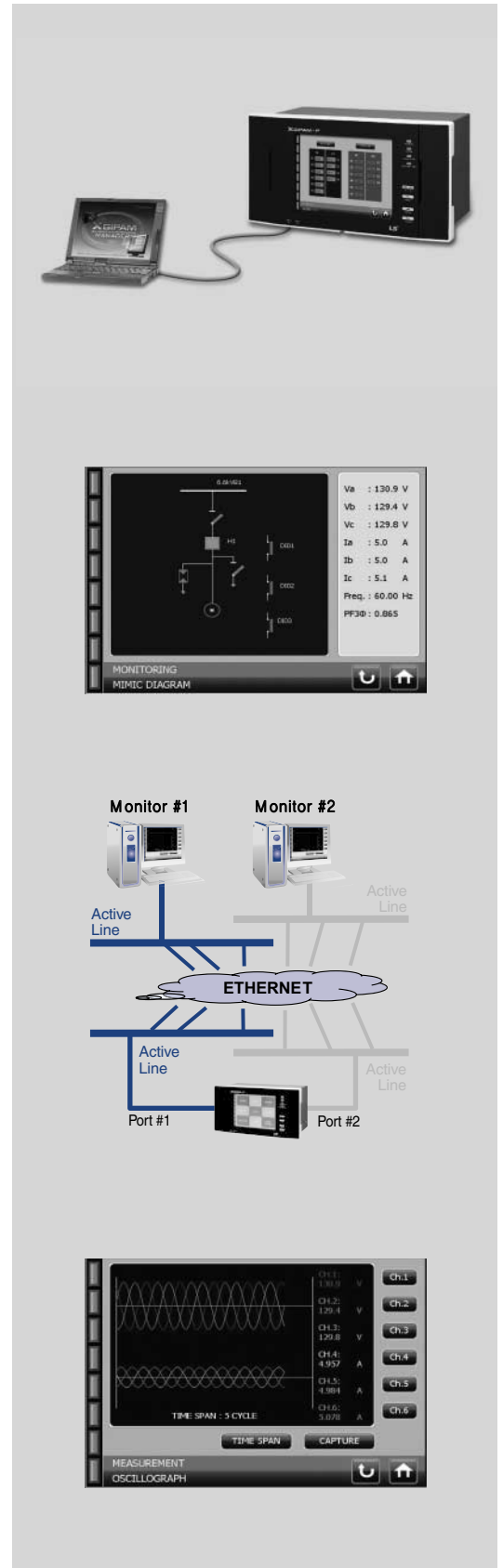

neXt Generation Intelligent Device

Features

Intelligent Device

Input/Output points monitoring and control function

- Monitoring AI/AO variation rate through VOC(Value of Change) function
- Showing the status of Digital I/O and performing each point control.
- Multi SW control(6 switching devices) through Power output.

Advanced PQ(Power Quality) measurement

- Analysis/Masurement of Sag, Swell, Interruption
- Offering analyze of harmonics(up to 63rd levels)
(1~63 Harmonics and THD, TDD, K-factor)
- 0.2% of measurement accuracy for Current and Voltage and 0.5% for Power, Energy, etc.

Group setting function

- Available to configure up to 4 setting groups for each relay element
- Possible to change setting values automatically depending on field status.
- Automatically recognizing any change of the status in power system.

Supervision of CB Capacity Limit

- Calculation accumulating value of breaking current and operating times
- Tolerance monitoring of circuit break vacuum interrupter.

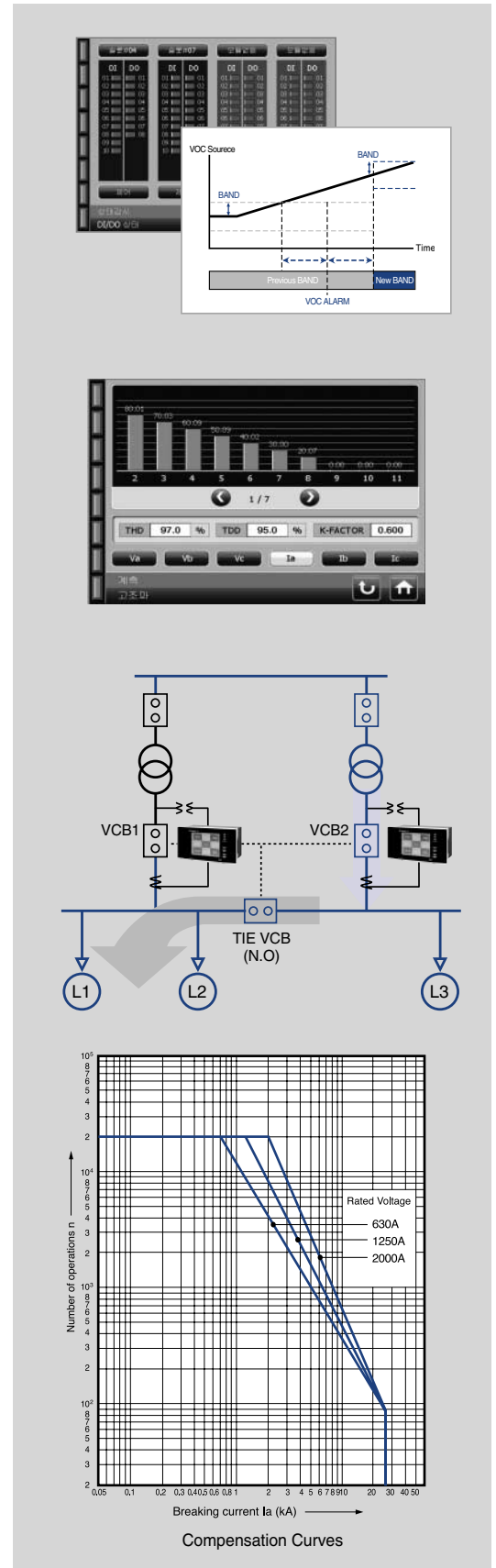

Application

Self Test Function

- It is a function which can test Relay operation & wiring
 - Simulation test can be carry out on various scenario
 - It is not available to test for SYNC, Reclosing, Temperature and ROCOF(df/dt)

Various extra monitoring, control and Fault recording

- SBO(Select Before Operating)
- TCS(Trip Circuit Supervision), TRS(Trip Relay Supervision)
- CBF(Circuit Breaker Failure), PTF(PT Failure)
- Saving 1,000 events, 200 Fault data
- Saving up to 62 fault waveform
(Available to choose the terms and conditions of saving waveform)

Trip Logic and PLC Function

- Real-time monitoring I/O points and logic status
- PLC function based on IEC Standard
- Available logic programming with using various I/O status or relay operation signal

Supporting SMS/Voice alarm module and USB port

- Providing voice message service
- Establishing 24-hour alarming and unmanned monitoring system through SMS information
- Available to download various recorded data to USB (Wave, Demand etc.) and upload setting value to device by X-GIPAM Manager

Bay Controller

- In possession of Reclosing(79) and directional overcurrent(67) element
- Various earth protection function (50NG, 51NG, 67N, 67G)
- Overvoltage/Undervoltage monitoring and protecting system(59,27)
- Overfrequency/Underfrequency monitoring and protecting system(81O, 81U)
- Available to control 4 Switching devices (CB DS etc)
- Expandable DI/DO structure

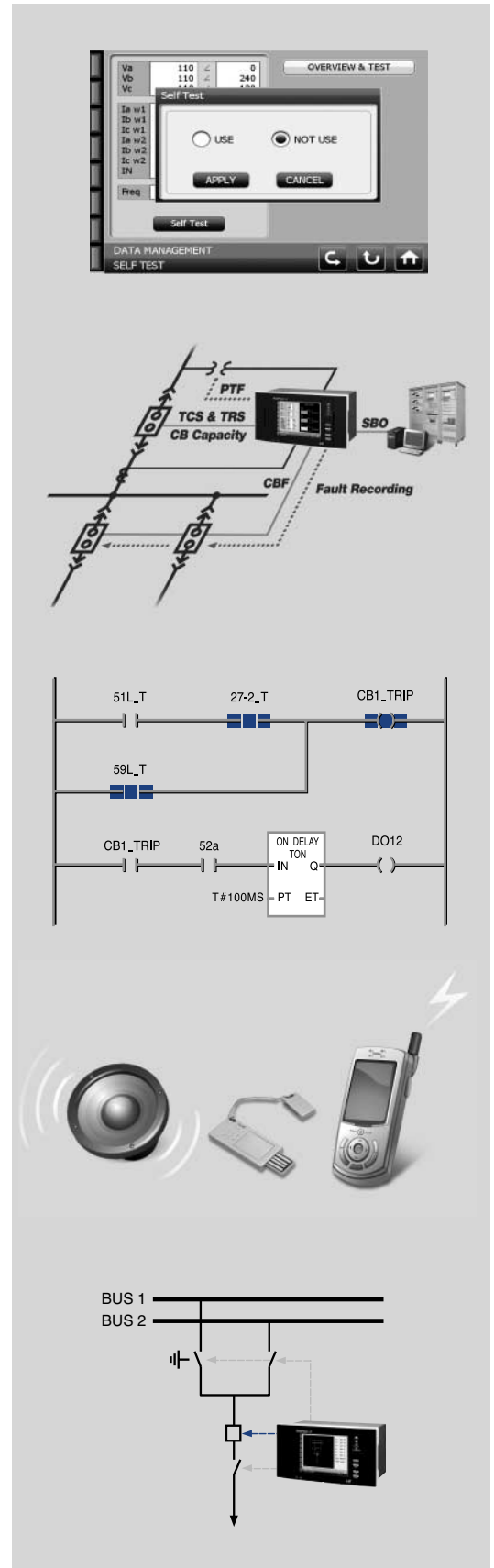

neXt Generation Intelligent Device

External & Structure

Structure

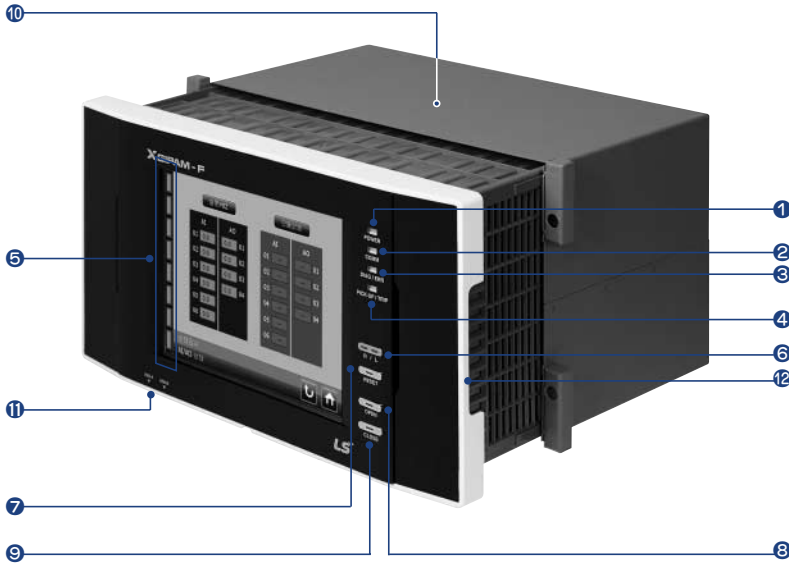

LED

- ① POWER LED (Green)
- ② COMM LED (Yellow)
- ③ DIAG/ERR LED (Red)
- ④ PICK-UP/TRIP LED (Red)
- ⑤ Fault assign LED (Virtual)

Key

- ⑥ R/L: Remote(Green)/ Local(Red)
- ⑦ RESET: Message Clear (Red: Trip)
- ⑧ OPEN(Green): CB Open
- ⑨ CLOSE(Red): CB Close

Other

- ⑩ X GIPAM Case
- ⑪ USB (Memory, PC, PLC)
- ⑫ Draw-Out handle

Rear View

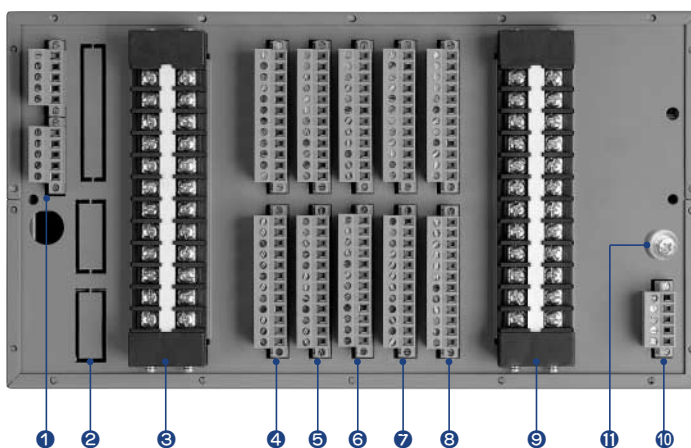

Slot

Module

- ① Main processing
- ② Slot #0 Extended communication Module
- ③ Slot #1 Arithmetic
- ④ Slot #2 AIO (Option)
- ⑤ Slot #3 AIO, SMS/Voice, Arc(Option)
- ⑥ Slot #4 DIO (Standard)
- ⑦ Slot #5 DIO (Bay, DG)
- ⑧ Slot #6 DIO (Option)
- ⑨ Slot #7 Arithmetic or DIO
- ⑩ Power module
- ⑪ FG terminal

Functional Block Diagram

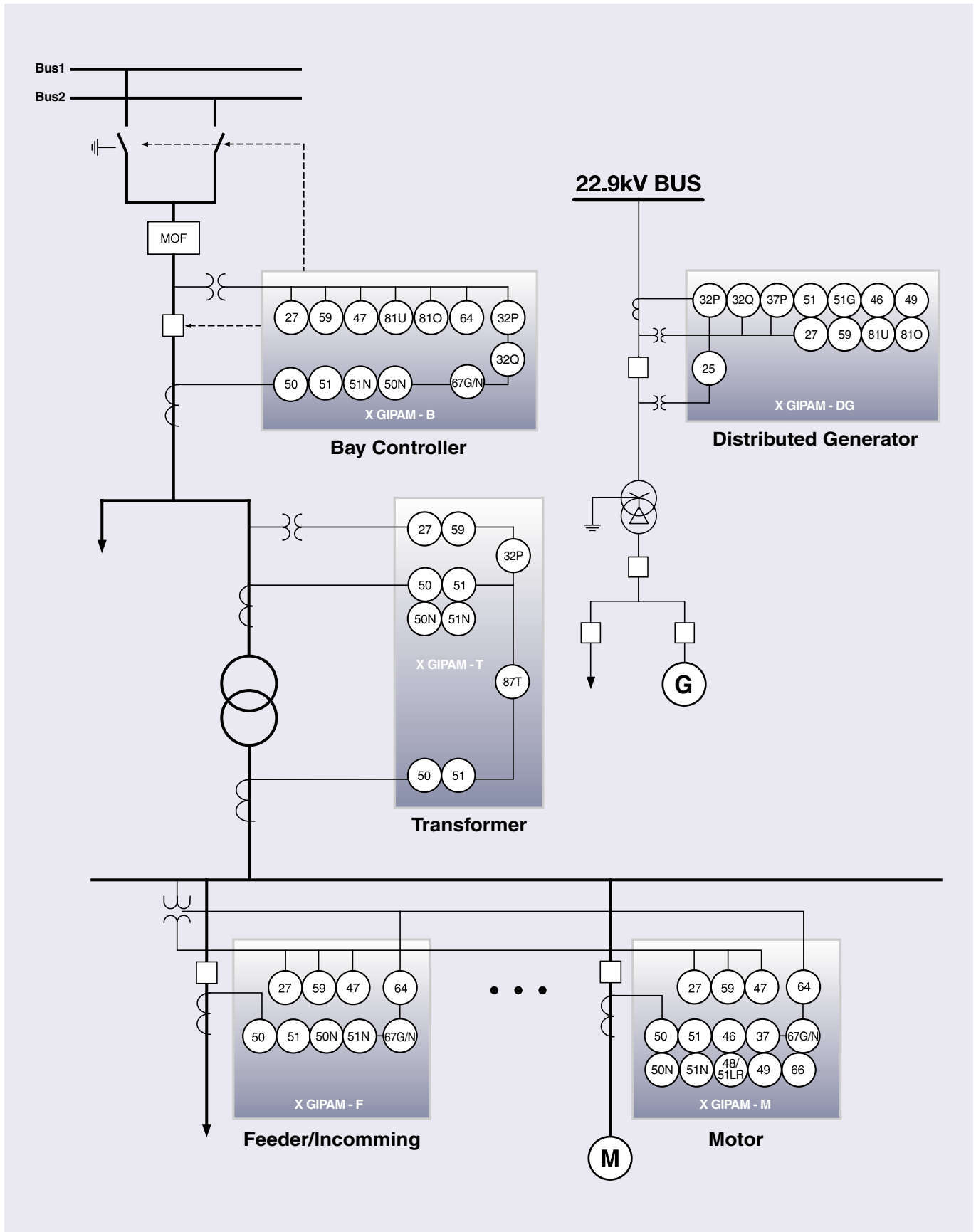

neXt Generation Intelligent Device

Technical Specifications

Type of Protection

Type	Vsage	Protection
X GIPAM - F	Feeder/Incomming	OCR(50/51), OCGR(50/51N), UVR(27), OVR(59), SGR(67G), DGR(67N), OVGR(64I/D), NSOVR(47N), POR(47), SYNC Check(25), Reclosing(79), Temperature(38)
X GIPAM - B	Bay Controller	OCR(50/51), OCGR(50/51N), UVR(27), OVR(59), SGR(67G), DGR(67N), OVGR(64I/D), NSOVR(47N), POR(47), SYNC Check(25), Reclosing(79), Temperature(38), DOCR(67I/D), NSOCR(46I/D), UFR(81U), OFR(81O), DPR(32P), DQR(32Q)
X GIPAM - M	Motor	OCR(50/51), OCGR(50/51N), UVR(27), OVR(59), SGR(67G), DGR(67N), OVGR(64I/D), NSOVR(47N), POR(47), Temperature(38), Stall/Locked Rotor(48/51LR), THR(49), DOCR(67I/D), UCR(37), NCH(66), NSOCR(46I/D),
X GIPAM - T	Transformer	OCR(50/51) × 2, OCGR(50/51N), UVR(27), OVR(59), Temperature(38), DPR(32P), DFR(87T)
X GIPAM - DG	Distributed Generator	OCR(50/51), OCGR(50/51N), UVR(27), OVR(59), DPR(32P), UPR(37P), DQR(32Q), UFR(81U), OFR(81O), DGR(67N), SYNC Check(25), DOCR(67I/D), NSOCR(46I/D), POR(47), NSOVR(47N), ROCOF(81R), SGR(67G), OVGR(64I/D)

Measurement function

Measurement	Range	Accuracy	Remarks
Voltage	0.0V ~ 999.999 kV	± 0.2%	Phase voltage, Line voltage
Zero-phase voltage	0.0V ~ 999.999 kV	± 2.0%	Vo
Phase voltage	0.0V ~ 999.999 kV	± 0.2%	VB
Unbalanced voltage rate	0.0% ~ 200.00%	± 2.0%	IEEE Std. 141
Reverse voltage	0.0V ~ 999.999 kA	± 1.0%	V ₂
Current	0.0A ~ 999.999 kA	± 0.2%	Phase current
Zero-phase current (CT4)	0.0A ~ 999.999 kA	± 2.0%	I _n
Zero-phase current (ZCT)	0.0A ~ 999.999 kA	± 1.0%	I _o
Reverse current	0.0A ~ 999.999 kA	± 1.0%	I ₂
Phase	0.0 ° ~ 360.0 °	± 5 °	-
Active power	0.00W ~ 9999.999 MW	± 0.5%	+ Forward, - Reverse
Reactive power	0.00VAR ~ 9999.999 MVAR	± 0.5%	-
Apparent power	0.00VA ~ 9999.999 MVA	± 1.0%	-
Active power amount	0.00WH ~ 99999.999 MWH	± 0.5%	+ Forward, - Reverse
Reactive power amount	0.00VARH ~ 99999.999 MVARH	± 0.5%	-
Frequency (Va)	45Hz ~ 65Hz	± 0.005Hz	-
Frequency (VB)	45Hz ~ 65Hz	± 0.005Hz	-
PF	-1.000 ~ 1.000	± 1.0%	Forward/Reverse
DPF	-1.000 ~ 1.000	± 1.0%	
Voltage hamonics	0.00% ~ 100.00%	± 5.0%	2nd ~ 63th harmonics THD, TDD, K-Factor
Current hamonics	0.00% ~ 100.00%	± 5.0%	
Active power demand	0.00W ~ 9999.999 MW	-	Peak Demand
Reactive power demand	0.00VAR ~ 9999.999 MVAR	-	
Voltage demand	0.3A ~ 999.999 kA	-	Each phase & Peak Demand
Load factor	0.0% ~ 100.000%	± 0.2%	Each phase current

Rating

Ratings

Type		Specification	
Wiring		3P3W, 3P4W	
Input	Frequency	50Hz or 60Hz	
	Voltage	PT: 100/ $\sqrt{3}$, 110/ $\sqrt{3}$, 120/ $\sqrt{3}$, 190/ $\sqrt{3}$, 100, 110, 120V GPT: 100-190V	
	Current	CT: 5A, ZCT: 1.5mA	
	Power consumption	Normal: Max. 30W, Operating: Max. 70W	
	Control voltage	AC/DC 110/125V ($\pm 20\%$)	
	Burden	PT: Max. 0.5VA (Phase PT Standard), CT: Max. 1.0VA	
	Output contact	TRIP	Rated
Open			AC 2500VA, DC 300W
ALARM		Close	AC 250V 5A / DC 30V 5A, Resistive Load
		Open	AC 1250VA, DC 150W
Insulation Resistance		Over DC 500V 10M Ω	
Dielectric Strength		AC 2kV(1kV) / for 1 min	
Overload withstand	Current circuit	3 In for 3 hours, 20 In for 2 seconde	
	Voltage circuit	1.15Vn for 3 hours	
Fast Transient Disturbance		Power Input 4kV, Other Input 2kV	
Electrostatic Discharge(ESD)		Air 8kV, Contact 6kV	
Operation temperature		-10°C ~ 55°C	
Storage temperature		-25°C ~ 70°C	
Humidity		30% ~ 80%	
Others		Non-impact place, Non-air pollution place	
Weight		7 kg (HMI: 2kg)	
Standard		IEC 60255-22-1: 1MHz Burst disturbance tests IEC 60255-22-2: Electrostatic discharge tests IEC 60255-22-3: Radiated radio frequency electromagnetic field IEC 60255-22-4: Electrical fast transient/burst immunity test IEC 60255-22-5: Surge immunity test IEC 60255-22-6: Immunity to conducted disturbances induced by radio frequency fields IEC 60255-22-7: Power frequency immunity test IEC 60255-11: Interruptions to and alternating component (ripple) in d.c. auxiliary quantity of measuring relay IEC 60255-25: Electromagnetic emission tests for measuring relays and protection equipment KEMC 1120 IEC 16850-6, 7-1, 7-2, 7-3, and 8-1	

neXt Generation Intelligent Device

Characteristics

X GIPAM - F

Protection	Operating part	Setting range	Operating characteristics	Operating time ^(Note)	Delay time	Remarks
OCR (50)	Stage 1	OFF, 0.10~32.00In/0.01In	Instantaneous	30msec and below	-	-
	Stage 2		Definite	0.050~300.000s/0.001s		
OCR (51)	Stage 1	OFF, 0.02~10.00In/0.01In	Definite	0.050~300.000s/0.001s	-	IEC SI/VI/EI/LI ANSI SI/VI/LI KEPCO SI/VI
	Stage 2		Inverse	0.05~1.2/0.01		
OCGR (50N)	Stage 1	OFF, 0.1~32.00In/0.01In	Instantaneous	30msec and below	-	-
	Stage 2		Definite	0.050~300.000s/0.001s		
OCGR (51N)	Stage 1	OFF, 0.02~10.00In/0.01In	Definite	0.050~300.000s/0.001s	-	IEC SI/VI/EI/LI ANSI SI/VI/LI KEPCO SI/VI
	Stage 2		Inverse	0.05~1.2/0.01		
SGR (67G)	Stage 1	OFF, 0.6~6.0mA/0.1mA Vo: 0V, 8V~80V/1V	Definite	0.050~10.000s/0.001s	-	If the zero phaes voltage is set to 0, the zero phase current will act.
	Stage 2	Characteristics angle: 0~±90°/1°				
DGR (67N)	Stage 1	OFF, 0.02~10.00In/0.01In Vo: 8~80V/1V	Instantaneous Definite	45msec and below 0.050~300.000s/0.001s	- -	IEC SI/VI/EI/LI ANSI SI/VI/LI KEPCO SI/VI
	Stage 2	Characteristics angle: 0~±90°/1° Operating range: 60~87°/1°	Inverse	0.05~1.20/0.01	0~300.000s/0.001s	
UVR (27)	Stage 1	OFF, 0.10~1.10Vn/0.01Vn Auto Reset: Enable/Disable	Definite	0.050~300.000s/0.001s	-	Dead Voltage Block: 0.05Vn
	Stage 2	Dead Voltage: Enable/Disable				
OVR (59)	Stage 1	OFF, 0.80~1.60Vn/0.01	Definite	0.050~300.000s/0.001s	-	IEC SI/VI/EI/LI ANSI SI/VI/EI
	Stage 2		Inverse	0.01~1.20/0.01		
OVGR (64I)	Stage 1	OFF, 5~80V/1V	Instantaneous	30msec and below	-	-
	Stage 2		Definite	0.050~300.000s/0.001s		
OVGR (64D)	Stage 1	OFF, 5~80V/1V	Definite	0.050~300.000s/0.001s	-	IEC SI/VI/EI/LI ANSI SI/VI/EI
	Stage 2		Inverse	0.05~1.20/0.01		
NSOVR (47N)	Stage 1	OFF, 11~120V/1V	Definite	0.050~300.000s/0.001s	-	All 3 phase voltage must be over 5V.
	Stage 2					
POR (47)	Stage 1	OFF, 2.0~100%/1%	Definite	0.050~300.000s/0.001s	-	-
	Stage 2					
Synchro-check (25)	Stage 1	V Diff: OFF, 2~50V/1V Phase Diff: OFF, 5~45/1° F Diff: 0.01~0.50/0.01Hz Dead V: 0.2~0.4Vn/0.01Vn	-	After the synchronous condition are satisfied, it operation within 1sec.	-	0.5Vn~1.2Vn
		Stage 2	OFF, 20~180℃/1℃	Definite	0.050~300.000s/0.001s	-
Temperature(38)	Stage 1	OFF, 20~180℃/1℃	Definite	0.050~300.000s/0.001s	-	-
	Stage 2					
Reclosing (79)	Stage 1	Reclosing counts: 1 ~ 5 times • Prepare Timer: 0.020 s ~ 60.000 s (0.001 s) • Dead Timer: 5, 0.060 s ~ 300.000 s (0.001 s) • CB Operation Timer: 0.05 s ~ 0.500 s (0.001 s) • Reclaim Time: 1.000 s ~ 300.000 s (0.001 s)				• Scheme: Dead Bus-Dead Line, Dead Bus-Live Line, Live Bus-Dead Line, Live Bus-Live Line • Dead: 0 ~ 0.1Vn • Live: 0.5Vn ~

Note) The operating time is based on 60Hz.

X GIPAM - B

Protection	Operating part	Setting range	Operating characteristics	Operating time ^(Note)	Delay time	Remarks
OCR (50)	Stage 1	OFF, 0.10~32.00In/0.01In	Instantaneous Definite	30msec and below 0.050~300.000s/0.001s	-	-
	Stage 2					
OCR (51)	Stage 1	OFF, 0.02~10.00In/0.01In	Definite Inverse	0.050~300.000s/0.001s 0.05~1.2/0.01	-	IEC SI/V/I/EI/LI ANSI SI/V/I/LI KEPCO SI/V/I
	Stage 2					
OCGR (50N)	Stage 1	OFF, 0.1~32.00In/0.01In	Instantaneous Definite	30msec and below 0.050~300.000s/0.001s	-	-
	Stage 2					
OCGR (51N)	Stage 1	OFF, 0.02~10.00In/0.01In	Definite Inverse	0.050~300.000s/0.001s 0.05~1.2/0.01	-	IEC SI/V/I/EI/LI ANSI SI/V/I/LI KEPCO SI/V/I
	Stage 2					
SGR (67G)	Stage 1	OFF, 0.6~6.0mA/0.1mA Vo: 0V, 8V~80V/1V Characteristics angle: 0~±90°/1°	Definite	0.050~10.000s/0.001s	-	If the zero phases voltage is set to 0, the zero phase current will act.
	Stage 2					
DGR (67N)	Stage 1	OFF, 0.02~10.00In/0.01In Vo: 8~80V/1V Characteristics angle: 0~±90°/1° Operating range: 60~87°/1°	Instantaneous Definite Inverse	45msec and below 0.050~300.000s/0.001s 0.05~1.2/0.01	-	IEC SI/V/I/EI/LI ANSI SI/V/I/LI KEPCO SI/V/I
	Stage 2					
UVR (27)	Stage 1	OFF, 0.10~1.10Vn/0.01Vn Auto Reset: Enable/Disable Dead Voltage: Enable/Disable	Definite	0.050~300.000s/0.001s	-	Dead Voltage Block : 0.05Vn
	Stage 2					
OVR (59)	Stage 1	OFF, 0.80~1.60Vn/0.01	Definite Inverse	0.050~300.000s/0.001s 0.01~1.20/0.01	-	IEC SI/V/I/EI/LI ANSI SI/V/I/EI
	Stage 2					
OVGR (64I)	Stage 1	OFF, 5~80V/1V	Instantaneous Definite	30msec and below 0.050~300.000s/0.001s	-	-
	Stage 2					
OVGR (64D)	Stage 1	OFF, 5~80V/1V	Definite Inverse	0.050~300.000s/0.001s 0.05~1.20/0.01	-	IEC SI/V/I/EI/LI ANSI SI/V/I/EI
	Stage 2					
NSOVR (47N)	Stage 1	OFF, 11~120V/1V	Definite	0.050~300.000s/0.001s	-	All 3 phase voltage must be over 5V.
	Stage 2					
POR (47)	Stage 1	OFF, 2.0~100%/1%	Definite	0.050~300.000s/0.001s	-	-
	Stage 2					
Synchro-check (25)	Stage 1	V Diff: OFF, 2~50V/1V Phase Diff: OFF, 5~45/1° F Diff: 0.01~0.50/0.01Hz Dead V: 0.2~0.4Vn/0.01Vn	-	1sec and below	-	0.5Vn ~1.2Vn
Temperature (38)	Stage 1	OFF, 20~180°C/1°C	Definite	0.050~300.000s/0.001s	-	-
	Stage 2					
UFR (81U)	Stage 1	50Hz: off, 50~60Hz/0.05Hz Block: 0.50~0.90Vn/0.01Vn	Definite	0.100~300.000s/0.001s	-	PT #1 or PT #5
	Stage 2					
	Stage 3					
	Stage 4					
OFR (81O)	Stage 1	50Hz: off, 50~60Hz/0.05Hz Block: 0.50~0.90Vn/0.01Vn	Definite	0.100~300.000s/0.001s	-	-
	Stage 2					
	Stage 3					
	Stage 4					
DPR (32P)	Stage 1	OFF, 0.01~1.50Pn/0.01Pn (Forward, Reverse)	Definite	0.100~300.000s/0.001s	-	-
	Stage 2					
DQR (32Q)	Stage 1	OFF, 0.02~1.50Qn/0.01Qn (Forward, Reverse)	Definite	0.100~300.000s/0.001s	-	-
	Stage 2					
DOCR (67I)	Stage 1	OFF, 0.10~32.00In/0.01In Characteristics angle: 0~±90°/1° Operating range: 60~87°/1° Forward/Reverse	Instantaneous Definite	45msec and below 0.050~300.000s/0.001s	-	-
	Stage 2					
DOCR (67D)	Stage 1	OFF, 0.02~10.00In/0.01In V(a-b), V(b-c), V(c-a) Characteristics angle: 0~±90°/1° Operating range: 60~87°/1° Forward/Reverse	Definite Inverse	0.050~300.000s/0.001s 0.05~1.20/0.01	-	IEC SI/V/I/EI/LI ANSI SI/V/I/EI KEPCO SI/V/I
	Stage 2					
NSOCR (46I)	Stage 1	OFF, 0.1~2.0/0.01In	Instantaneous Definite	50msec and below 0.050~300.000s/0.001s	-	-
	Stage 2					
NSOCR (46D)	Stage 1	OFF, 0.05~2.00/0.01In	Definite Inverse	0.050~300.000s/0.001s 0.05~1.20/0.01	-	IEC SI/V/I/EI/LI ANSI SI/V/I/EI
	Stage 2					
Reclosing (79)	Stage 1	Reclosing counts: 1 ~ 5 times • Prepare Timer: 0.020 s ~ 60.000 s (0.001s) • Dead Timer: 5, 0.060 s ~ 300.000 s (0.001s) • CB Operation Timer: 0.05 s ~ 0.500 s (0.001s) • Reclaim Time: 1.000 s ~ 300.000 s (0.001s)		• Scheme: Dead Bus-Dead Line, Dead Bus-Live Line, Live Bus-Dead Line, Live Bus-Live Line • Dead: 0 ~ 0.1Vn • Live: 0.5Vn ~		

Note) The operating time is based on 60Hz.

neXt Generation Intelligent Device

Characteristics

X GIPAM - M

Protection	Operating part	Setting range	Operating characteristics	Operating time ^{Note)}	Delay time	Remarks
OCR (50)	Stage 1	OFF, 0.10 ~ 32.00In/0.01In	Instantaneous	30msec and below	-	-
	Stage 2		Definite	0.050 ~ 300.000s/0.001s		
OCR (51)	Stage 1	OFF, 0.02 ~ 10.00In/0.01In	Definite	0.050 ~ 300.000s/0.001s	-	IEC SI/M/EI/LI ANSI SI/M/LI KEPCO SI/M
	Stage 2		Inverse	0.05 ~ 1.2/0.01		
OCGR (50N)	Stage 1	OFF, 0.1 ~ 32.00In/0.01In	Instantaneous	30msec and below	-	-
	Stage 2		Definite	0.050 ~ 300.000s/0.001s		
OCGR (51N)	Stage 1	OFF, 0.02 ~ 10.00In/0.01In	Definite	0.050 ~ 300.000s/0.001s	-	IEC SI/M/EI/LI ANSI SI/M/LI KEPCO SI/M
	Stage 2		Inverse	0.05 ~ 1.2/0.01		
SGR (67G)	Stage 1	OFF, 0.6 ~ 6.0mA/0.1mA Vo : 0V, 8V ~ 80V/1V	Definite	0.050 ~ 10.000s/0.001s	-	If the zero phases voltage is set to 0, the zero phase current will act.
	Stage 2	Characteristics angle: 0~±90°/1°				
DGR (67N)	Stage 1	OFF, 0.02 ~ 10.00In/0.01In Vo : 8 ~ 80V/1V	Instantaneous	45msec and below	-	IEC SI/M/EI/LI ANSI SI/M/LI KEPCO SI/M
	Stage 2	Characteristics angle: 0~±90°/1° Operating range: 60~87°/1°	Definite	0.050 ~ 300.000s/0.001s		
UVR (27)	Stage 1	OFF, 0.10~1.10Vn/0.01Vn Auto Reset: Enable/Disable	Definite	0.050 ~ 300.000s/0.001s	-	Dead Voltage Block : 0.05Vn
	Stage 2	Dead Voltage: Enable/Disable				
OVR (59)	Stage 1	OFF, 0.80 ~ 1.60Vn/0.01	Definite	0.050 ~ 300.000s/0.001s	-	IEC SI/M/EI/LI ANSI SI/M/EI
	Stage 2		Inverse	0.01 ~ 1.20/0.01		
OVGR (64I)	Stage 1	OFF, 5 ~ 80V/1V	Instantaneous	30msec and below	-	-
	Stage 2		Definite	0.050 ~ 300.000s/0.001s		
OVGR (64D)	Stage 1	OFF, 5 ~ 80V/1V	Definite	0.050 ~ 300.000s/0.001s	-	IEC SI/M/EI/LI ANSI SI/M/EI
	Stage 2		Inverse	0.05 ~ 1.20/0.01		
NSOVR (47N)	Stage 1	OFF, 11 ~ 120V/1V	Definite	0.050 ~ 300.000s/0.001s	-	All 3 phase voltage must be over 5V.
	Stage 2					
POR (47)	Stage 1	OFF, 2.0 ~ 100%/1%	Definite	0.050 ~ 300.000s/0.001s	-	-
	Stage 2					
DOCR (67I)	Stage 1	OFF, 0.10 ~ 32.00In/0.01In Characteristics angle: 0~±90°/1°	Instantaneous	45msec and below	-	-
	Stage 2	Operating range: 60~87°/1° Forward/Reverse				
DOCR (67D)	Stage 1	OFF, 0.02 ~ 10.00In/0.01In V(a-b), V(b-c), V(c-a)	Definite	0.050 ~ 300.000s/0.001s	-	IEC SI/M/EI/LI ANSI SI/M/LI KEPCO SI/M
	Stage 2	Characteristics angle: 0~±90°/1° Operating range: 60~87°/1° Forward/Reverse				
NSOCR (46I)	Stage 1	OFF, 0.1 ~ 2.0/0.01In	Instantaneous	50msec and below	-	-
	Stage 2		Definite	0.050 ~ 300.000s/0.001s		
NSOCR (46D)	Stage 1	OFF, 0.05 ~ 2.00/0.01In	Definite	0.050 ~ 300.000s/0.001s	-	IEC SI/M/EI/LI ANSI SI/M/EI
	Stage 2		Inverse	0.05 ~ 1.20/0.01		
THR (49)		<ul style="list-style-type: none"> • FLC(Full Load Current) : 0.20 ~ 2.00 / 0.01In • OLC(Over Load Constant) : 0.8 ~ 1.2 / 0.01 • SF(Service Factor) : 0.8 ~ 1.2 / 0.01 • 동작치 : OFF, 50 ~ 100 / 1% 	Inverse	$\tau_1 \tau_2 : 2.0 \sim 60\text{min}/0.1\text{min}$	-	한시특성 Hot, Cold *k factor = SF×OLC
Stall (48)	기동시간설정치 1.0~300.0S	OFF, 0.2 ~ 10.0In/0.01In	Definite	0.05 ~ 300s/0.001	-	운전중 회전차 구속
Lock (51LR)		OFF, 0.2 ~ 10.0In/0.01In	Inverse	T/L: 0.05 ~ 1.20/0.01 0.05 ~ 300.0/0.001sec	0 ~ 300s/0.001s	IEC VI, IEC EI
UCR (37)	Stage1	OFF, 0.1 ~ 0.9 In/0.01In	Definite	0.100 ~ 300.000s/0.001s	-	Dead Current Block
	Stage2					
NCH(66)		<ul style="list-style-type: none"> • 기동횟수제한 : OFF, 1 ~ 5회 • 기동제한시간 : OFF, 1 ~ 60분 • 기동허용시간 : 10 ~ 60분 • 잔류열량제한 : OFF, 10 ~ 80% 				
Temperature (38)	Stage 1	OFF, 20 ~ 180°C/1°C	Definite	0.050 ~ 300.000s/0.001s	-	-
	Stage 2					

Note) The operating time is based on 60Hz.

X GIPAM - T

Protection	Operating part	Setting range	Operating characteristics	Operating time ^(Note)	Delay time	Remarks
OCR-1(50)	Stage 1	OFF, 0.10~32.00In/0.01In	Instantaneous	30msec and below	-	-
	Stage 2		Definite	0.050~300.000s/0.001s		
OCR-1(51)	Stage 1	OFF, 0.02~10.00In/0.01In	Definite	0.050~300.000s/0.001s	-	IEC SI/VI/EI/LI ANSI SI/VI/LI KEPCO SI/VI
	Stage 2		Inverse	0.05~1.2/0.01		
OCGR (50N)	Stage 1	OFF, 0.1~32.00In/0.01In	Instantaneous	30msec and below	-	-
	Stage 2		Definite	0.050~300.000s/0.001s		
OCGR (51N)	Stage 1	OFF, 0.02~10.00In/0.01In	Definite	0.050~300.000s/0.001s	-	IEC SI/VI/EI/LI ANSI SI/VI/LI KEPCO SI/VI
	Stage 2		Inverse	0.05~1.2/0.01		
OCR-2 (50)	Stage 1	OFF, 0.10~32.00In/0.01In	Instantaneous	30msec and below	-	-
	Stage 2		Definite	0.050~300.000s/0.001s		
OCR-2 (51)	Stage 1	OFF, 0.02~10.00In/0.01In	Definite	0.050~300.000s/0.001s	-	IEC SI/VI/EI/LI ANSI SI/VI/LI KEPCO SI/VI
	Stage 2		Inverse	0.05~1.2/0.01		
UVR (27)	Stage 1	OFF, 0.10~1.10Vn/0.01Vn Auto Reset: Enable/Disable Dead Voltage: Enable/Disable	Definite	0.050~300.000s/0.001s	-	Dead Voltage Block : 0.05Vn
	Stage 2					
OVR (59)	Stage 1	OFF, 0.80~1.60Vn/0.01	Definite	0.050~300.000s/0.001s	-	IEC SI/VI/EI/LI ANSI SI/VI/EI
	Stage 2		Inverse	0.01~1.20/0.01		
DPR (32P)	Stage 1	OFF, 0.01~1.50Pn/0.01Pn (Forward, Reverse)	Definite	0.100~300.000s/0.001s	-	-
	Stage 2					
Temperature (38)	Stage 1	OFF, 20~180℃/1℃	Definite	0.050~300.000s/0.001s	-	-
	Stage 2					
DFR(87T)	Stage1	OFF, 2~32 In/0.01In			40ms and below	-
	Stage 2	OFF, 0.2~1.0In/0.01In Slope 1: 15~100%/1% Slope 2: 15~100%/1% Knee Point: 1.0~20.0In/0.1In Inrush Inhibit: ON (5~50%/1%) : OFF Io Elimination: ON/OFF	Definite	-	0, 0.05~300s/0.001s	-

Note) The operating time is based on 60Hz.

neXt Generation Intelligent Device

Characteristics

X GIPAM - DG

Protection	Operating part	Setting range	Operating characteristics	Operating time ^{Note)}	Delay time	Remarks
OCR (50)	Stage 1	OFF, 0.10 ~ 32.00In/0.01In	Instantaneous Definite	30msec and below 0.050 ~ 300.000s/0.001s	-	-
	Stage 2					
OCR (51)	Stage 1	OFF, 0.02 ~ 10.00In/0.01In	Definite Inverse	0.050 ~ 300.000s/0.001s 0.05 ~ 1.2/0.01	-	IEC SI/V/I/EI/LI ANSI SI/V/I/LI KEPCO SI/V/I
	Stage 2					
OCGR (50N)	Stage 1	OFF, 0.1 ~ 32.00In/0.01In	Instantaneous Definite	30msec and below 0.050 ~ 300.000s/0.001s	-	-
	Stage 2					
OCGR (51N)	Stage 1	OFF, 0.02 ~ 10.00In/0.01In	Definite Inverse	0.050 ~ 300.000s/0.001s 0.05 ~ 1.2/0.01	-	IEC SI/V/I/EI/LI ANSI SI/V/I/LI KEPCO SI/V/I
	Stage 2					
DGR (67N)	Stage 1	OFF, 0.02 ~ 10.00In/0.01In Vo : 8 ~ 80V/1V Characteristics angle: $0 \sim \pm 90^\circ / 1^\circ$ Operating range: $60 \sim 87^\circ / 1^\circ$	Instantaneous Definite Inverse	45msec and below 0.050 ~ 300.000s/0.001s 0.05 ~ 1.20/0.01	-	IEC SI/V/I/EI/LI ANSI SI/V/I/LI KEPCO SI/V/I
	Stage 2					
SGR (67G)	Stage 1	OFF, 0.6 ~ 6.0mA/0.1mA Vo : 0V, 8V ~ 80V/1V Characteristics angle: $0 \sim \pm 90^\circ / 1^\circ$	Definite	0.050 ~ 10.000s/0.001s	-	If the zero phases voltage is set to 0, the zero phase current will act.
	Stage 2					
UVR (27)	Stage 1	OFF, 0.10~1.10Vn/0.01Vn Auto Reset: Enable/Disable Dead Voltage: Enable/Disable	Definite	0.050 ~ 300.000s/0.001s	-	Dead Voltage Block : 0.05Vn
	Stage 2					
OVR (59)	Stage 1	OFF, 0.80 ~ 1.60Vn/0.01	Definite Inverse	0.050 ~ 300.000s/0.001s 0.01 ~ 1.20/0.01	-	IEC SI/V/I/EI/LI ANSI SI/V/I/EI
	Stage 2					
OVGR (64I)	Stage 1	OFF, 5 ~ 80V/1V	Instantaneous Definite	30msec and below 0.050 ~ 300.000s/0.001s	-	-
	Stage 2					
OVGR (64D)	Stage 1	OFF, 5 ~ 80V/1V	Definite Inverse	0.050 ~ 300.000s/0.001s 0.05 ~ 1.20/0.01	-	IEC SI/V/I/EI/LI ANSI SI/V/I/EI
	Stage 2					
NSOVR (47N)	Stage 1	OFF, 11 ~ 120V/1V	Definite	0.050 ~ 300.000s/0.001s	-	-
	Stage 2					
POR (47)	Stage 1	OFF, 2.0 ~ 100%/1%	Definite	0.050 ~ 300.000s/0.001s	-	All 3 phase voltage must be over 5V.
	Stage 2					
DPR (32P)	Stage 1	OFF, 0.01 ~ 1.50Pn/0.01Pn Forward/Reverse	Definite	0.100 ~ 300.000s/0.001s	-	-
	Stage 2					
DQR (32Q)	Stage 1	OFF, 0.01 ~ 1.50Qn/0.01Qn Forward/Reverse	Definite	0.100 ~ 300.000s/0.001s	-	Qa=IaVasin(θ), Qa=Ia(Vb-Vc)
	Stage 2					
Synchro-check (25)	Stage 1	V Diff : OFF, 2 ~ 50V/1V Phase Diff : OFF, 5 ~ 45/1° F Diff : 0.01 ~ 0.50/0.01Hz Dead V : 0.2 ~ 0.4Vn/0.01Vn	-	After the synchronous condition are satisfied, it operation within 1sec.	-	Dead Voltage Block: 0.5Vn ~ 1.2Vn
DOCR (67I)	Stage 1	OFF, 0.10 ~ 32.00In/0.01In Characteristics angle: $0 \sim \pm 90^\circ / 1^\circ$ Operating range: $60 \sim 87^\circ / 1^\circ$ Forward/Reverse	Instantaneous Definite	45msec and below 0.050 ~ 300.000s/0.001s	-	-
	Stage 2					
DOCR (67D)	Stage 1	OFF, 0.02 ~ 10.00In/0.01In V(a-b), V(b-c), V(c-a) Characteristics angle: $0 \sim \pm 90^\circ / 1^\circ$ Operating range: $60 \sim 87^\circ / 1^\circ$ Forward/Reverse	Definite Inverse	0.050 ~ 300.000s/0.001s 0.05 ~ 1.20/0.01	-	IEC SI/V/I/EI/LI ANSI SI/V/I/LI KEPCO SI/V/I
	Stage 2					
UFR (81U)	Stage 1	OFF, 50 ~ 60Hz/0.05Hz Block : 0.50 ~ 0.90Vn/0.01Vn	Definite	0.100 ~ 300.000s/0.001s	-	PT #1 or PT #5
	Stage 2					
	Stage 3					
	Stage 4					
OFR (81O)	Stage 1	OFF, 60 ~ 70Hz/0.05Hz Block : 0.50 ~ 0.90Vn/0.01Vn	Definite	0.100 ~ 300.000s/0.001s	-	PT #1 or PT #5
	Stage 2					
	Stage 3					
	Stage 4					
NSOCR (46I)	Stage 1	OFF, 0.1 ~ 2.0/0.01In	Instantaneous Definite	50msec and below 0.050 ~ 300.000s/0.001s	-	-
	Stage 2					
NSOCR (46D)	Stage 1	OFF, 0.05 ~ 2.00/0.01In	Definite Inverse	0.050 ~ 300.000s/0.001s 0.05 ~ 1.20/0.01	-	IEC SI/V/I/EI/LI ANSI SI/V/I/EI
	Stage 2					
UPR (37P)	Stage1	OFF, 0.02 ~ 0.80Pn/0.01Pn	Definite	0.10 ~ 300.00/0.001s	-	-
	Stage2					
ROCOF (81R)	Stage1	0.1 ~ 2.0/0.1Hz/s UV Block : 50 ~ 100/1V	Definite	0.2 ~ 60.0/0.001s	-	-
	Stage2					
	Stage3					
	Stage4					

Note) The operating time is based on 60Hz.

Wiring

X GIPAM - F/B/M/DG (3P3W)

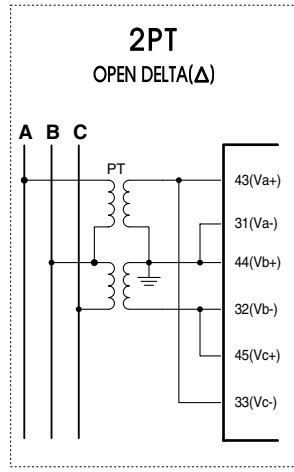
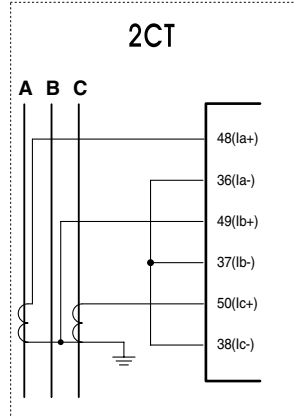
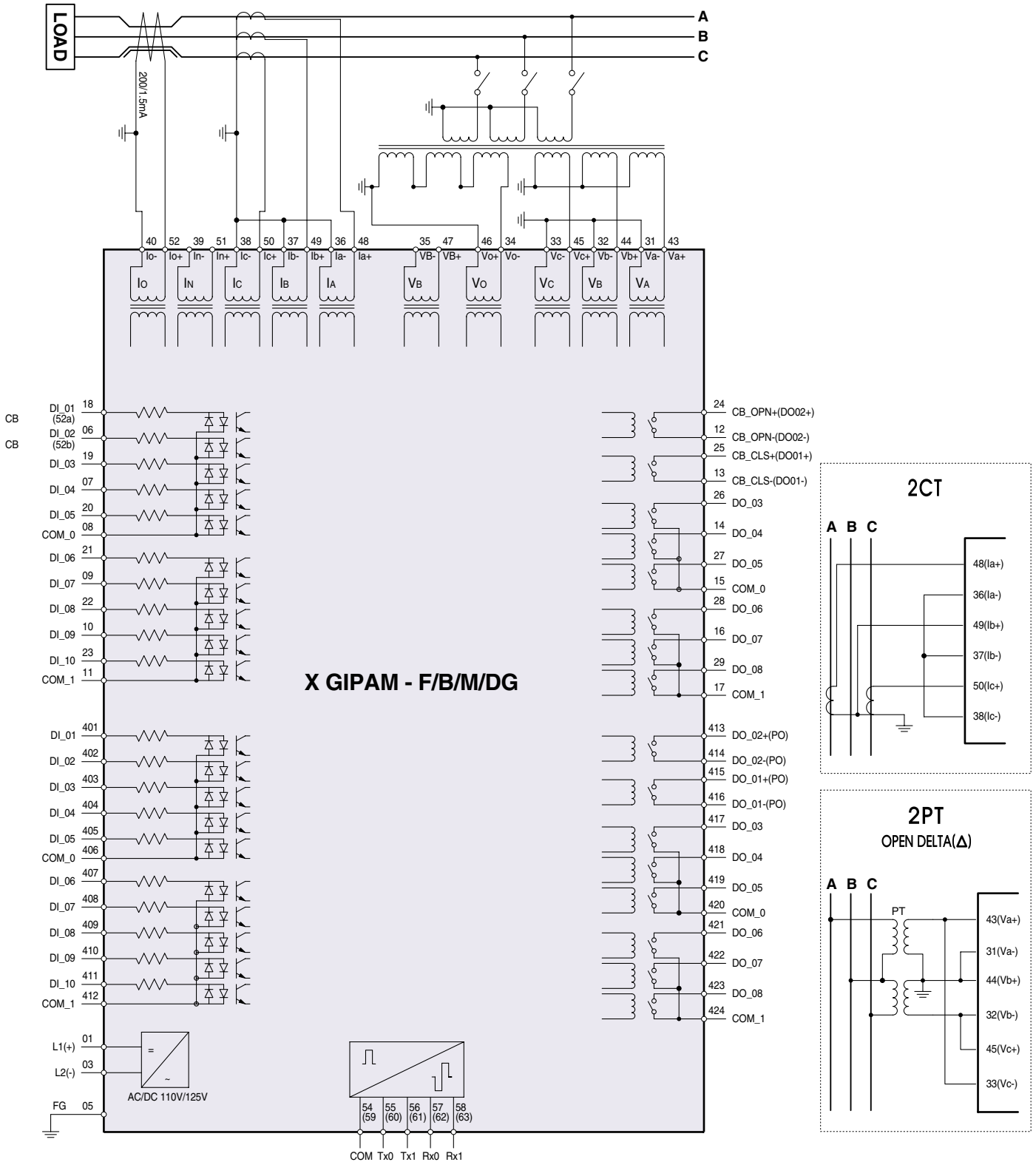

Note) For example is Number 4B described B in slot #4

neXt Generation Intelligent Device

Wiring

X GIPAM - F/B/M/DG (3P4W)

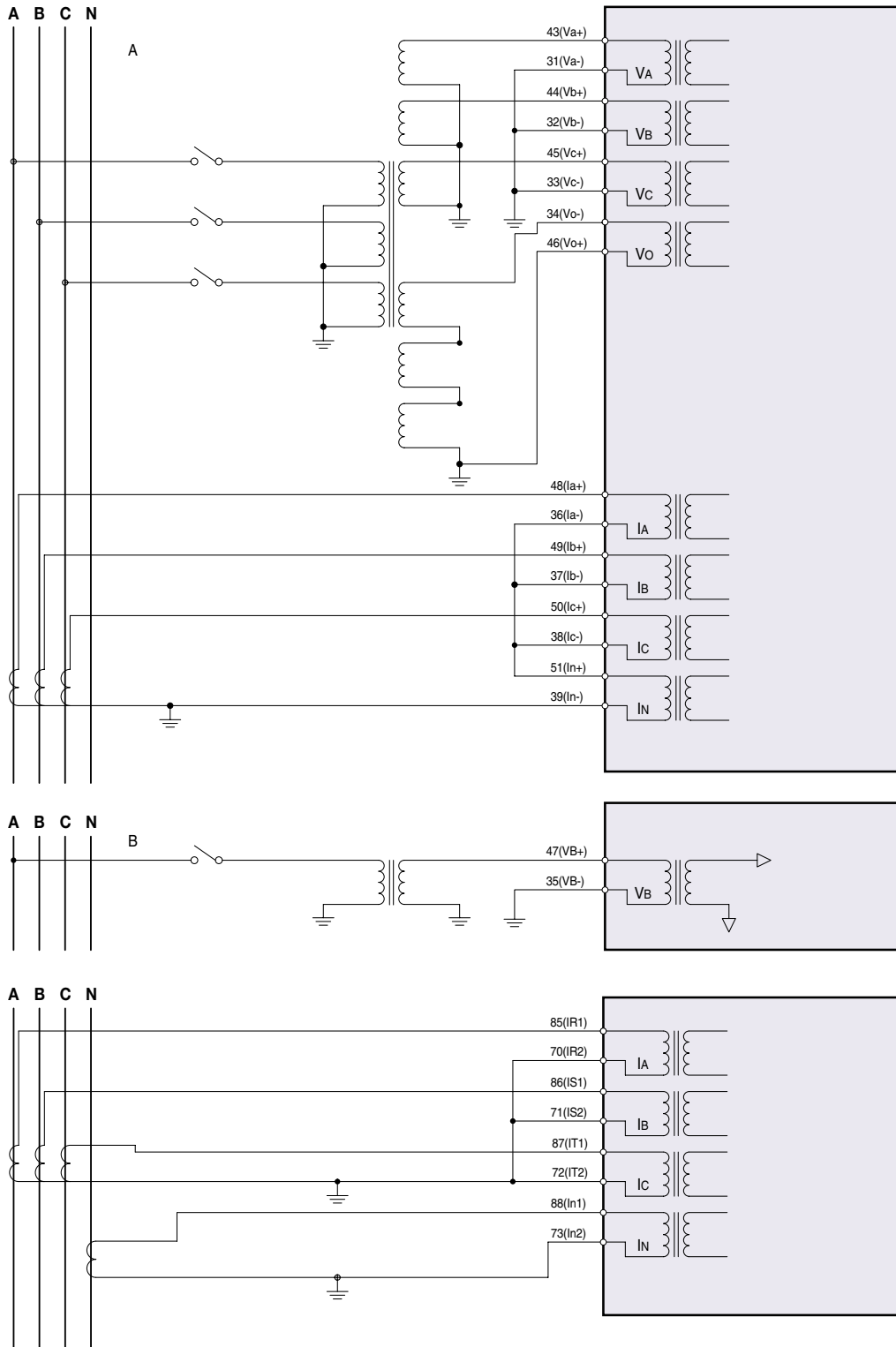

X GIPAM - T

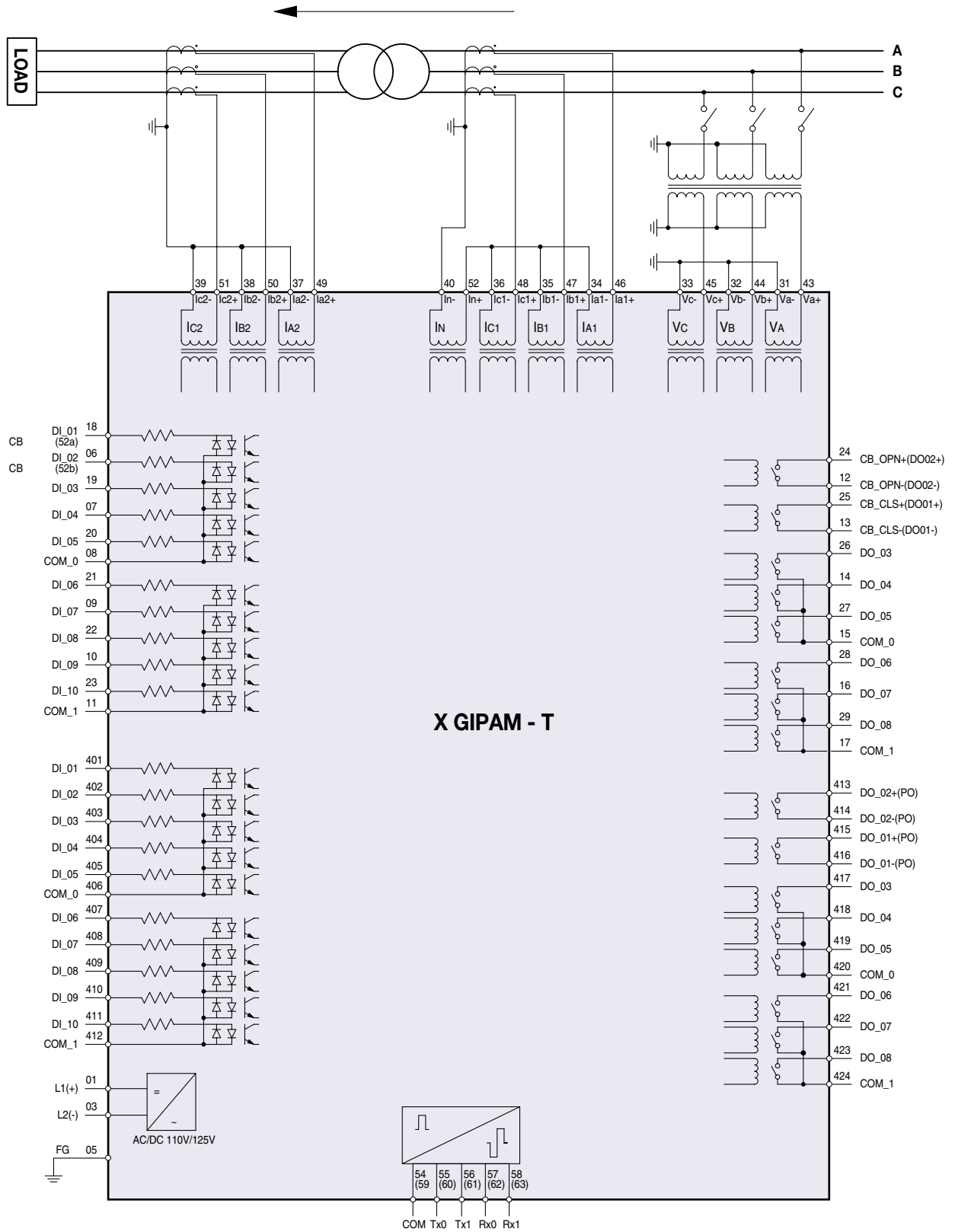

Note) For example is Number 4B described B in slot #4

neXt Generation Intelligent Device

Contact and Logic Usage

X GIPAM - F/B/M/DG

Comm	Extended Comm	CT/PT	Slot2	Slot3	Slot4	Slot5	Slot6	Slot7	
54 COM A 55 TxDO A 56 TxD1 A 57 RxDO A 58 RxD1 A	64 FX RXA 65 FX TXA 66 FX RXB 67 FX TXB	42 BLK BLK 30 43 Va+ Va- 31 44 Vb+ Vb- 32 45 Vc+ Vc- 33 46 Vo+ Vo- 34 47 VB+ VB- 35 48 Ia+ Ia- 36 49 Ib+ Ib- 37 50 Ic+ Ic- 38 51 In+ In- 39 52 Io+ Io- 40 53 BLK BLK 41	01 AI01+ 02 AI01- 03 AI02+ 04 AI02- 05 AI03+ 06 AI03- 07 AI04+ 08 AI04- 09 AI05+ 10 AI05- 11 AI06+ 12 AI06-	01 AI01+ 02 AI01- 03 AI02+ 04 AI02- 05 AI03+ 06 AI03- 07 AI04+ 08 AI04- 09 AI05+ 10 AI05- 11 AI06+ 12 AI06-	01 DI01 02 DI02 03 DI03 04 DI04 05 DI05 06 COM0 07 DI06 08 DI07 09 DI08 10 DI09 11 DI10 12 COM1	01 DI01 02 DI02 03 DI03 04 DI04 05 DI05 06 COM0 07 DI06 08 DI07 09 DI08 10 DI09 11 DI10 12 COM1	01 DI01 02 DI02 03 DI03 04 DI04 05 DI05 06 COM0 07 DI06 08 DI07 09 DI08 10 DI09 11 DI10 12 COM1	18 DI01 DI02 06 19 DI03 DI04 07 20 DI05 COM0 08 21 DI06 DI07 09 22 DI08 DI09 10 23 DI10 COM1 11 24 CB OPN+ (DO02+) CB OPN- (DO02-) 12 25 CB CLS+ (DO01+) CB CLS- (DO01-) 13 26 DO03 DO04 14 27 DO05 COM0 15 28 DO06 DO07 16 29 DO08 COM1 17	01 L1/+ 02 L2/- 03 L2/- 04 L2/- 05 FG
59 COM B 60 TxDO B 61 TxD1 B 62 RxDO B 63 RxD1 B	68 LAN A 69 LAN B		13 AO01+ 14 AO01- 15 AO02+ 16 AO02- 17 AO03+ 18 AO03- 19 AO04+ 20 AO04- 21 22 23 24	13 AO01+ 14 AO01- 15 AO02+ 16 AO02- 17 AO03+ 18 AO03- 19 AO04+ 20 AO04- 21 22 23 24	13 DO02+(P0) 14 DO02-(P0) 15 DO01+(P0) 16 DO01-(P0) 17 DO03 18 DO04 19 DO05 20 COM0 21 DO06 22 DO07 23 DO08 24 COM1	13 DO02+(P0) 14 DO02-(P0) 15 DO01+(P0) 16 DO01-(P0) 17 DO03 18 DO04 19 DO05 20 COM0 21 DO06 22 DO07 23 DO08 24 COM1	13 DO02+(P0) 14 DO02-(P0) 15 DO01+(P0) 16 DO01-(P0) 17 DO03 18 DO04 19 DO05 20 COM0 21 DO06 22 DO07 23 DO08 24 COM1		
Comm	Extended Comm	CT/PT	AI/AO (Option)	AI/AO (Option)	DI/DO	DI/DO (Option)	DI/DO (Option)	DI/DO	PWR
RS-485	100Base-FX or 100/10Base-F	3I+I _N +I ₀ 3V+V ₀ +V _S	AI: 6Channel AO: 4Channel	AI: 6Channel AO: 4Channel	DI: 10 Point DO: 8Point -S/W2Point -General 6Point	DI: 10 Point DO: 8Point -S/W2Point -General 6Point	DI: 10 Point DO: 8Point -S/W2Point -General 6Point	DI: 10 Point DO: 8Point -S/W2Point -General 6Point	

X GIPAM - T

Comm	Extended Comm	CT/PT	Slot2	Slot3	Slot4	Slot5	Slot6	Slot7	
54 COM A 55 TxDO A 56 TxD1 A 57 RxDO A 58 RxD1 A	64 FX RXA 65 FX TXA 66 FX RXB 67 FX TXB	42 BLK BLK 30 43 Va+ Va- 31 44 Vb+ Vb- 32 45 Vc+ Vc- 33 46 Ia1+ Ia1- 34 47 Ib1+ Ib1- 35 48 Ic1+ Ic1- 36 49 Ia2+ Ia2- 37 50 Ib2+ Ib2- 38 51 Ic2+ Ic2- 39 52 In+ In- 40 53 BLK BLK 41	01 AI01+ 02 AI01- 03 AI02+ 04 AI02- 05 AI03+ 06 AI03- 07 AI04+ 08 AI04- 09 AI05+ 10 AI05- 11 AI06+ 12 AI06-	01 AI01+ 02 AI01- 03 AI02+ 04 AI02- 05 AI03+ 06 AI03- 07 AI04+ 08 AI04- 09 AI05+ 10 AI05- 11 AI06+ 12 AI06-	01 DI01 02 DI02 03 DI03 04 DI04 05 DI05 06 COM0 07 DI06 08 DI07 09 DI08 10 DI09 11 DI10 12 COM1	01 DI01 02 DI02 03 DI03 04 DI04 05 DI05 06 COM0 07 DI06 08 DI07 09 DI08 10 DI09 11 DI10 12 COM1	01 DI01 02 DI02 03 DI03 04 DI04 05 DI05 06 COM0 07 DI06 08 DI07 09 DI08 10 DI09 11 DI10 12 COM1	18 DI01 DI02 06 19 DI03 DI04 07 20 DI05 COM0 08 21 DI06 DI07 09 22 DI08 DI09 10 23 DI10 COM1 11 24 CB OPN+ (DO02+) CB OPN- (DO02-) 12 25 CB CLS+ (DO01+) CB CLS- (DO01-) 13 26 DO03 DO04 14 27 DO05 COM0 15 28 DO06 DO07 16 29 DO08 COM1 17	01 L1/+ 02 L2/- 03 L2/- 04 L2/- 05 FG
59 COM B 60 TxDO B 61 TxD1 B 62 RxDO B 63 RxD1 B	68 LAN A 69 LAN B		13 AO01+ 14 AO01- 15 AO02+ 16 AO02- 17 AO03+ 18 AO03- 19 AO04+ 20 AO04- 21 22 23 24	13 AO01+ 14 AO01- 15 AO02+ 16 AO02- 17 AO03+ 18 AO03- 19 AO04+ 20 AO04- 21 22 23 24	13 DO02+(P0) 14 DO02-(P0) 15 DO01+(P0) 16 DO01-(P0) 17 DO03 18 DO04 19 DO05 20 COM0 21 DO06 22 DO07 23 DO08 24 COM1	13 DO02+(P0) 14 DO02-(P0) 15 DO01+(P0) 16 DO01-(P0) 17 DO03 18 DO04 19 DO05 20 COM0 21 DO06 22 DO07 23 DO08 24 COM1	13 DO02+(P0) 14 DO02-(P0) 15 DO01+(P0) 16 DO01-(P0) 17 DO03 18 DO04 19 DO05 20 COM0 21 DO06 22 DO07 23 DO08 24 COM1		
Comm	Extended Comm	CT/PT	AI/AO (Option)	AI/AO (Option)	DI/DO	DI/DO (Option)	DI/DO (Option)	DI/DO	PWR
RS-485	100Base-FX or 100/10Base-F	3I+3I _N +I ₀ 3V	AI: 6Channel AO: 4Channel	AI: 6Channel AO: 4Channel	DI: 10 Point DO: 8Point -S/W2Point -General 6Point	DI: 10 Point DO: 8Point -S/W2Point -General 6Point	DI: 10 Point DO: 8Point -S/W2Point -General 6Point	DI: 10 Point DO: 8Point -S/W2Point -General 6Point	

Dimension

Dimensions (with integrated HMI)

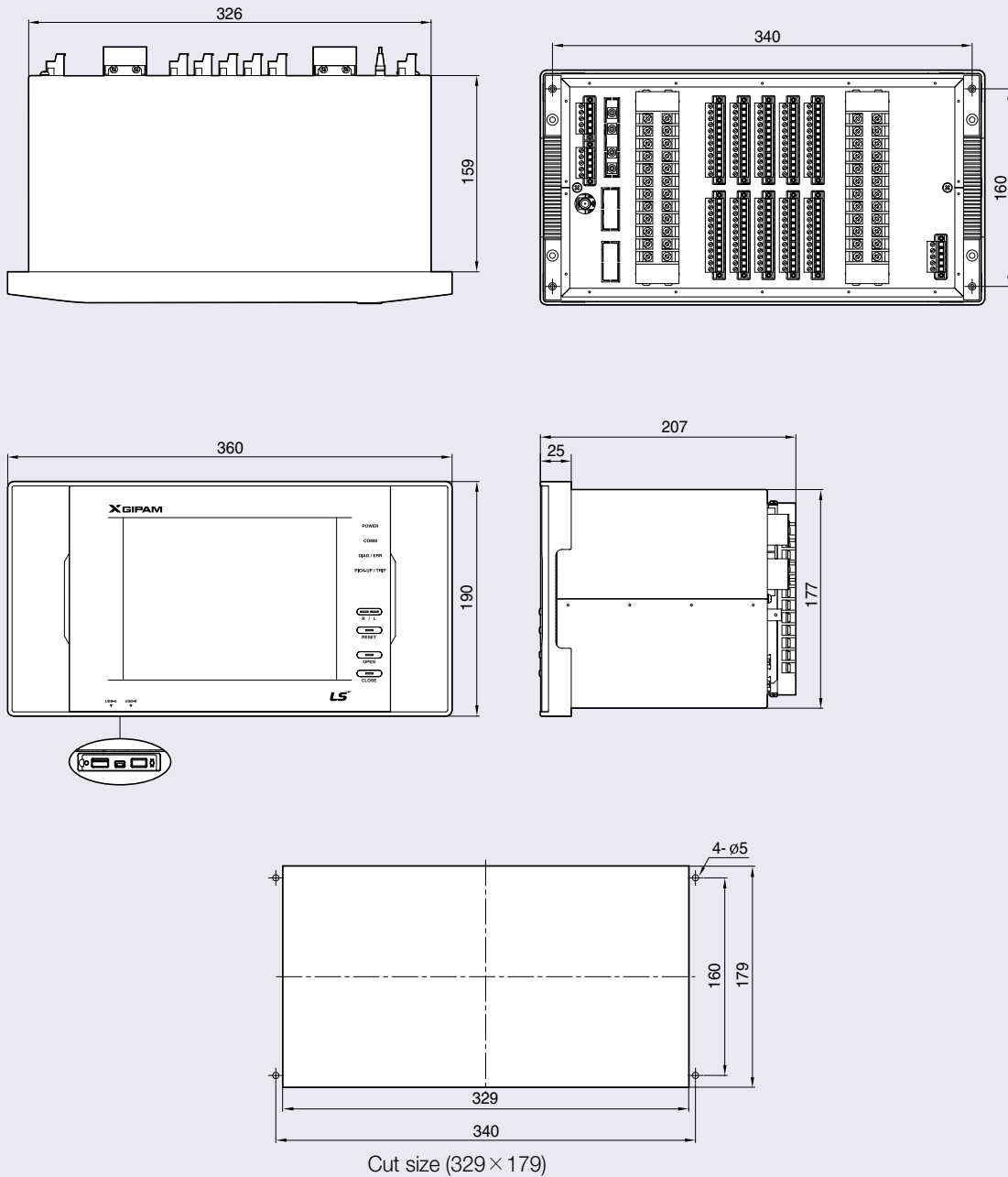

neXt Generation Intelligent Device

Odering

X GIPAM

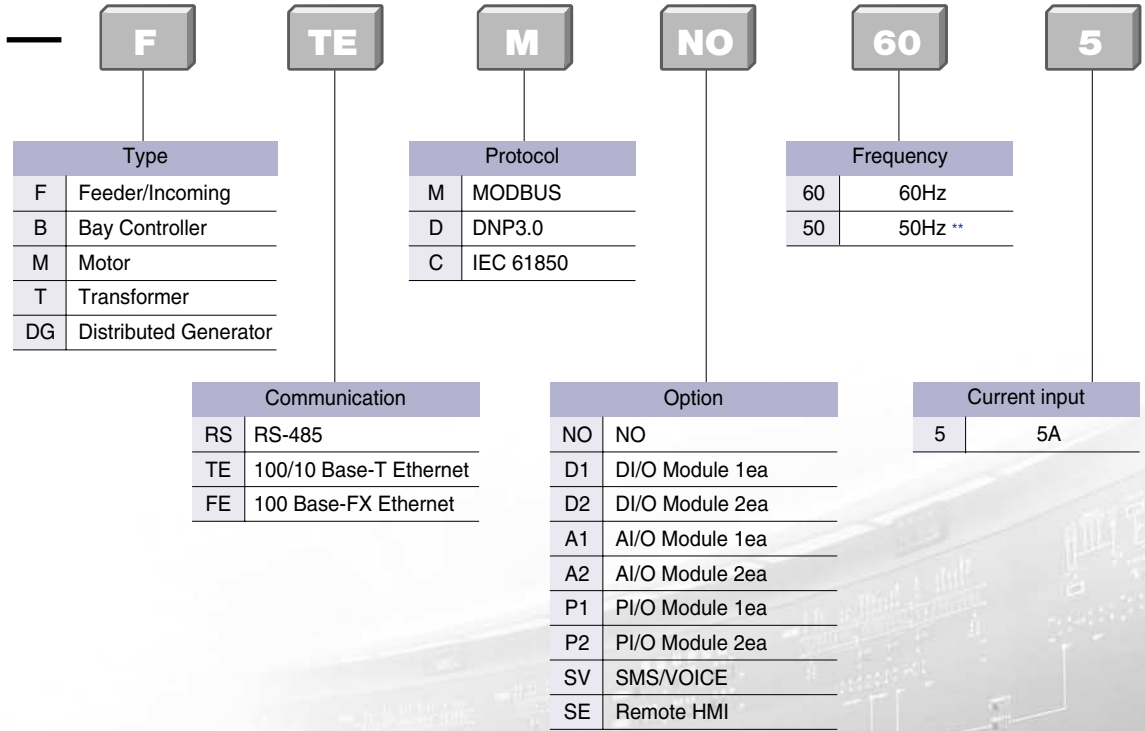

** For further information about 50Hz, please address inquiries to us separately.

neXt Generation Technology

X GIPAM



Digital Protection & Measurement Device



International
Usersgroup

IEC 61850 Certificate Level A¹

Page 1/2

No. 30920476-Consulting 09-1763

Issued to:
LS Industrial Systems Co., Ltd.
LS Tower 1026-6, Hogye-dong, Dongan-gu,
Anyang-si, Gyeonggi-do 431-848
Korea

For the product:
X GIPAM
Multifunctional Protection & Control Device
IEC61850 EXT. v1.0

Issued by:



The product has not shown to be non-conforming to:

IEC 61850-6, 7-1, 7-2, 7-3, 7-4 and 8-1

Communication networks and systems in substations

The conformance test has been performed according to IEC 61850-10 with product's protocol, model and technical issue implementation conformance statements: "X GIPAM Ext. v1.0 PICS", "X GIPAM Ext. v1.0 MICS", "X GIPAM Ext. v1.0 TICS" and product's extra information for testing: "X GIPAM Ext. v1.0 PIXIT".

The following IEC 61850 conformance blocks have been tested with a positive result (number of relevant and executed test cases / total number of test cases as defined in the UCA International Users Group Device Test procedures v2.2):

1	Basic Exchange (19/24)	12a	Direct Control (6/11)
2+	Data Set Definition (26/29)	12b	SBO Control (8/15)
5	Unbuffered Reporting (16/18)	12c	Enhanced Direct Control (6/13)
6	Buffered Reporting (18/20)	12d	Enhanced SBO Control (11/19)
9a	GOOSE Publish (6/12)	13	Time Synchronization (4/4)
9b	GOOSE Subscribe (9/10)	14	File Transfer (4/7)

This Certificate includes a summary of the test results as carried out at KEMA in The Netherlands with UniCasim 61850 version 3.19.02 with test suite 3.19.01 and UniCA 61850 analyzer 4.18.01. The test is based on the UCA International Users Group Device Test Procedures version 2.2. This document has been issued for information purposes only, and the original paper copy of the KEMA report: No. 30920476-Consulting 09-1762 will prevail.

The test has been carried out on one single specimen of the products as referred above and submitted to KEMA by LS Industries. The manufacturer's production process has not been assessed. This Certificate does not imply that KEMA has certified or approved any product other than the specimen tested.

Arnhem, August 28, 2009

W. Strabbing
Manager Intelligent Networks and Communication

M. Flohil
Senior Test Engineer

1 Level A - Independent Test lab with certified ISO 9000 or ISO 17025 Quality System

Copyright © KEMA Nederland B.V., Arnhem, the Netherlands. All rights reserved. Please note that any electronic version of this KEMA certificate is provided to KEMA's customer for convenience purposes only. It is prohibited to update or change it in any manner whatsoever, including but not limited to dividing it into parts. In case of a conflict between the electronic version and the original version, the original paper version issued by KEMA will prevail.

KEMA Nederland B.V.
Utrechtseweg 310, 6812 AR Arnhem P.O.Box 9035, 6800 ET Arnhem The Netherlands
T +31 26 356 61 42 F +31 26 351 54 56 sales@kema.com www.kema.com

GIPAM-2000

Digital Integrated Protection & Monitoring Device

The optimum protection which leads protective diagnosis and reliability improvement of own protection relay, quick accident analysis and maintenance & repair, preventive control, minimizing accident spread.



IEC 60255, KEMC 1120
ISO 9001, ISO 14001





N₂



Contents :

Features	N-2-6
Technical Specifications	N-2-9
Communications	N-2-11
Characteristics	N-2-12
Time Characteristic Curves	N-2-15
Wirings	N-2-19
Contact Usage	N-2-23
Dimension	N-2-25
Ordering	N-2-36



GIPAM-2000 series are multifunction microprocessor-based protection equipments suitable for all types of application such as distribution feeders. It can be also be used for management backup protection of incomings, feeders, transformers and high tension motors.



Digital Integrated Protection & Monitoring Equipment

Over current protection function includes protection elements such as over current, over current ground fault, selective ground fault current, directive ground fault current, negative sequence over current in each phase with regard to time delay or instantaneous elements. Moreover, it supports under voltage, over voltage, ground fault over voltage, phase reversal over voltage, etc. regarding voltage protection and thermal overload, rocked rotor, differential, ground fault differential regarding various kinds of protection functions. As it has differential, ground fault differential to protect a transformer, and the protection of secondary wires transformer is available too.

GIPAM-2000 can arrange easily as demand of users' need as well as apply to various sequences because the logic design through a simple logic program is available regarding input/output contacts.

GIPAM-2000 series provides various monitoring, measuring functions and it does easy accident analysis by storing data fires such as 800 events, 200 faults and maximum 128 cycle' s fault waveform. Furthermore, when accidents happens, alarm signal can put out during the operation in terms of self testing. GIPAM-2000 series provide IrDA Serial Ports for connecting PC which is performing the operation program, and they are



equipped with RS-485, optic communication ports to communicate with the upper systems. In addition, they support DNS 3.0, MODBUS protocol widely spread in the industrial electric section and I-NET which is the exclusive express communication system by LSIS.

Setting all protection function and monitoring as well as checking many kinds of functions are available through the operation program based on PC interface.

Digital Integrated Protection & Monitoring Device

Features

Easy GIPAM-2000 Setting

GIPAM-2000 series is simple to set all relay functions and verify all supported functions through the offered operation program (GIPAM OPTO MASTER) which is based on PC interface. After setting the each parameter, downloading data from the communication port on the front of GIPAM-2000 series leads completion of setting. It is very easy to maintain and repair due to the availability of download & upload.

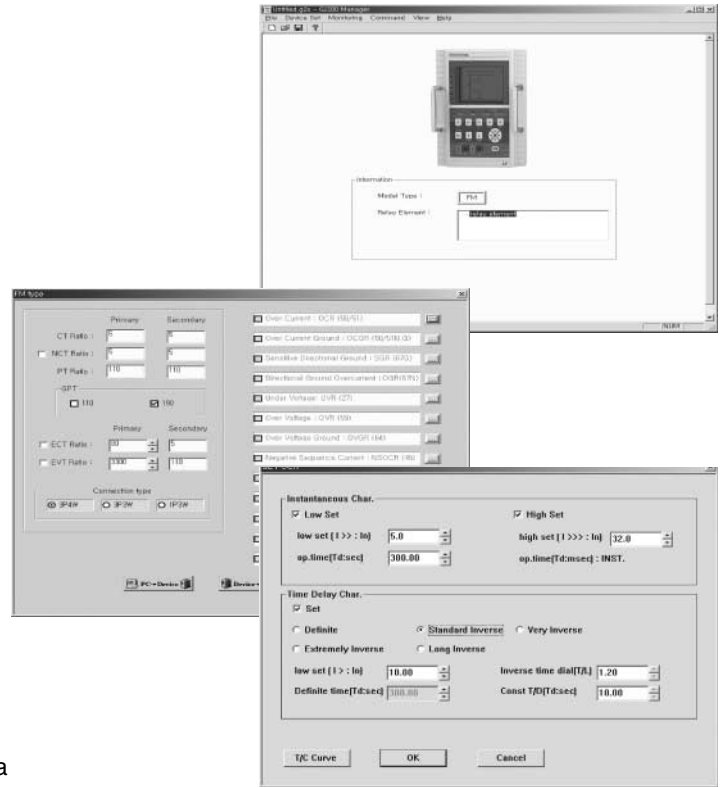

MIMIC Diagram & Graphic LCD

The 320×240 graphic LCD of GIPAM-2000 features a convenient MMI and various types of display. MIMIC diagram especially displays the system that GIPAM-2000 has been applied to in the form of a one-line diagram so as to see them at a glance, which enables easily the checking of operating status of the devices such as contacts or breakers according to the output of GIPAM-2000. MIMIC diagram can be designed in the operational program for the PC Interface by user.

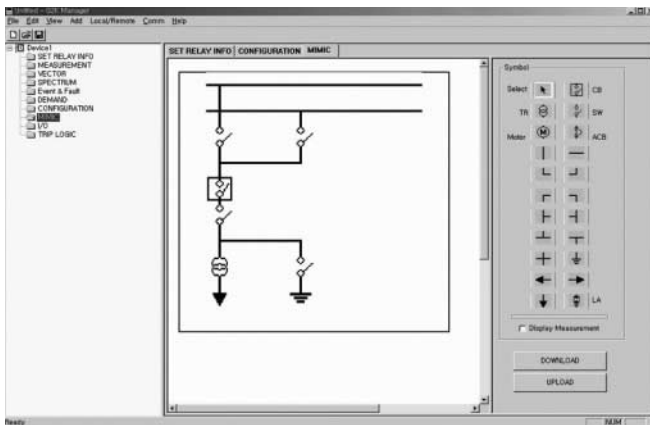

Harmonic Spectrum

GIPAM-2000 can display the harmonic analysis SPECTRUM, which enables the measurement and verification of current and voltage from the 2nd harmonic to 13th harmonic and THD (Total Harmonic Distortion) can be displayed together.

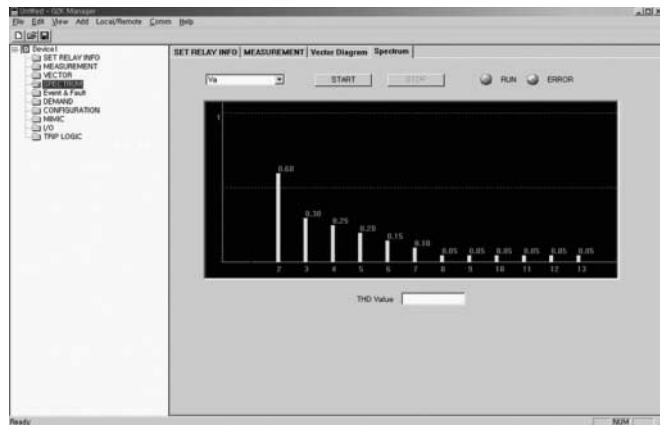

EVENT & FAULT RECORDING

GIPAM-2000 is able to store up to 800 events that are related to Protection & Measuring function, Breaker operation, Contact trip, operation information, and selfdiagnosis outcome. Moreover, in case of line and load fault incidents, GIPAM-2000 can store up to 200 detailed information regarding fault analysis, current fault, and voltage fault

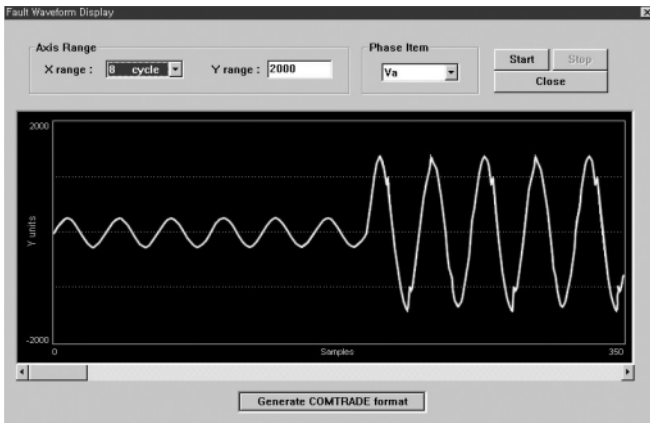

Fault waveforms are saved as a Comtrade (IEEE) file format to be analyzed its waveforms or used for fault simulations.

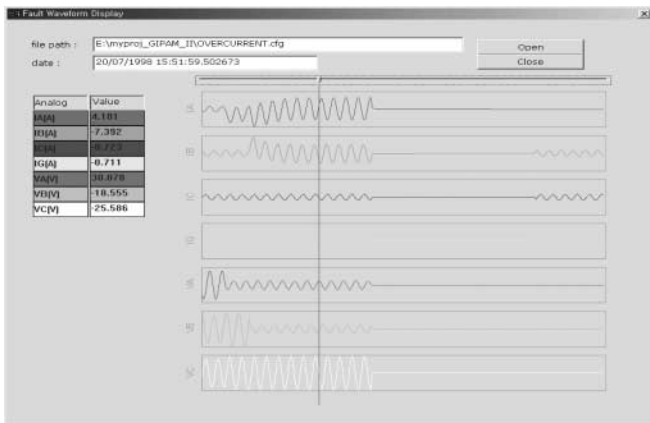

Sequence of Event(SOE) Function

GIPAM-2000 supports the SOE function that makes easy for reviewing fault analysis and operation information by recording events in sequence at 1ms' intervals regarding internal protection relay, breaker operation, or self-diagnosis abnormalities such as alarm contact output and others. These events including the latest registered one can be stored as many as 800. Each event can be verified in detail under the "EVENT LIST" section from the initial screen of "EVENT/FAULT REC" Menu. In addition, it is possible to save as files with GIPAM Manager (capable to manage more than 800).

Vector Diagram

GIPAM-2000 can display a vector diagram regarding the system's voltage, current, and phase through PC interface operating program. It is easy to comprehend its electric system's condition because of visualization from the diagram that verifies the amount of electricity.

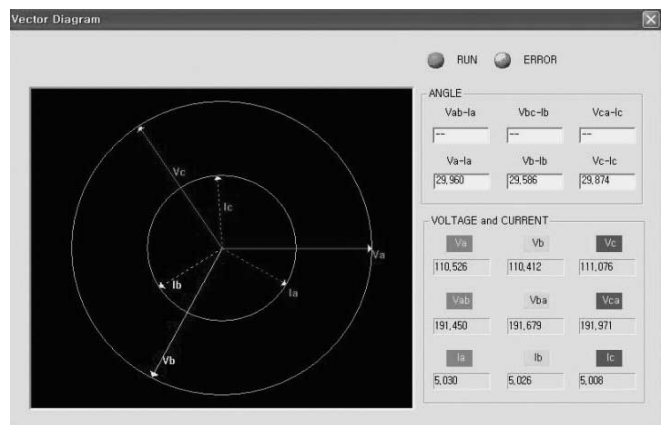

Time Characteristic Curve

By operating PC interface operating program, it is possible to verify time characteristic curves to check with arranged values after setting each protection relay. Therefore, it is very convenient to program protection relay. Besides, it is simple to make protection coordination among electric systems as well.

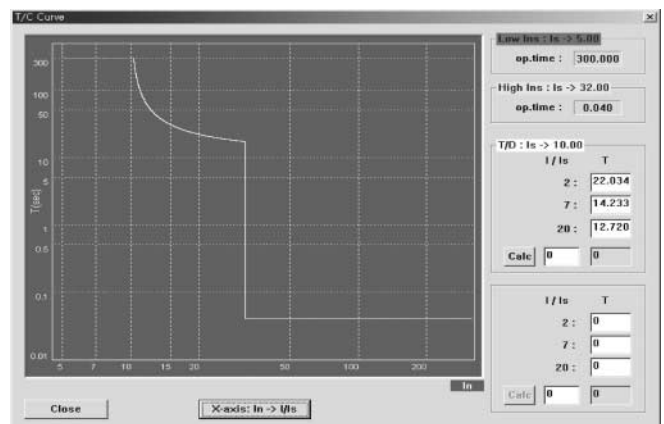

Digital Integrated Protection & Monitoring Device

Features

Select Before Operating(SBO) and Check Before Operating(CBO) Function

By choosing controlling Points first before sending out orders to where it is desired to control, control orders are executed only along with normal responses. This function enhances to control reliability and security. GIPAM-2000 applies SBO/CBO functions at CB control's power contact points. For selected control point, it will wait for control orders for 5 seconds after its response. If the control order won't be delivered within 5 seconds, it will be reset. The control functions will be executed only on the normal condition when orders were delivered within 5 seconds,

Various Communication Compatibilities

GIPAM is possible to select its communication from RS-485/422, Optic, Ethernet and I- NET. Its application to diverse systems is convenient in the industrial sites, because it supports various protocols such as DNP 3.0, MODBUS and exclusive I-NET protocol as well. Not only it is able to support the Ethernet communication mode through a protocol transformer enabling high speed data communications, but also it is possible to make up differentiated systems using H.A.(High Availability) communication supports. Moreover, the product's front side is equipped with an IrDA(infrared rays) port to provide easy access to upload/download with PC

TRIP LOGIC and SEQUENCE

Including a trip relay, GIPAM-2000 series' all I/O contact points and protection relay's operation signals can be managed by the logic that is directly designed by users. The logic can be easily arranged by using provided PC operating program, and applied to a variety of sequences.

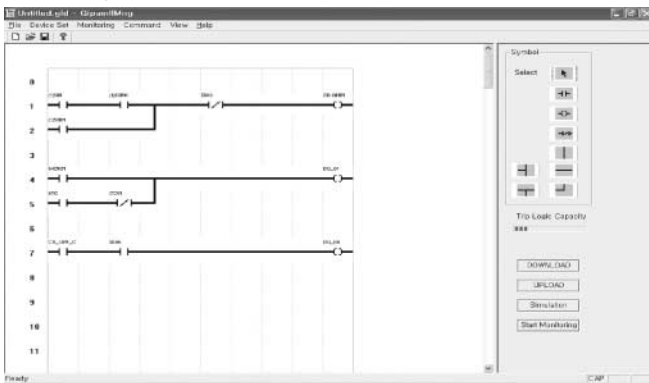

TRIP CIRCUIT SUPERVISION (TCS) & TRIP RELAY SUPERVISION (TRS)

To check circuit's condition, GIPAM-2000 internally make micro-current to flow on a trip circuit that is composed of breaker's trip coil and control voltage, and trip relay; and tests it every hour. By composing trip relay with 2 pole series, not 1 pole by itself, it will execute contact operation at regular cycle or requested time checking trip relay automatically without operation of a circuit breaker. After the automatic check-up, the result will be recorded as event and if fault happens, contact output will be printed to prevent accidents in advance.

CIRCUIT BREAKER FAILURE (CBF)

GIPAM-2000 supports breaker failure function that can prevent further extension of accident by controlling upper circuit breaker to trip, when lower circuit breaker failed to act despite protection relay was activated and sent trip signal for problems in the circuit. This function is not limited only on trip signal, but also includes CB Close/Open control failure, it will produce alarm output as well.

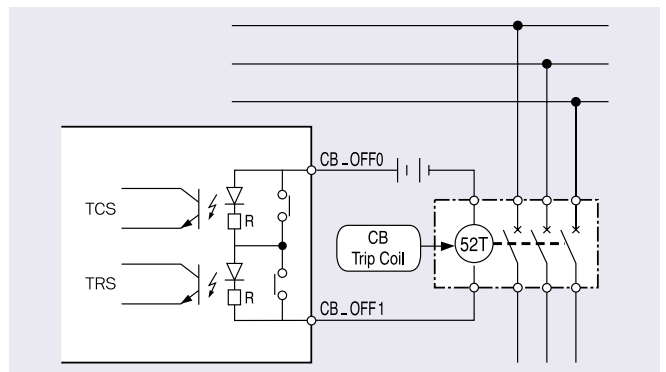

PT(VT) FAILURE

By detecting PT 2nd fuse melt-down in advance, it's possible to collect alarm message and logic prints which can be used to prevent unnecessary system cutoffs by protection relay operation of UVR and NSOVR. It does not activate under under-voltage or blackout situation, it compares with voltage current and on breaker conditions to decide PT fuse opening. By utilizing DO output, it can generate alarm signal and it can also make Trip Block to disable trip function. Replacing PT fuse will reset it immediately.

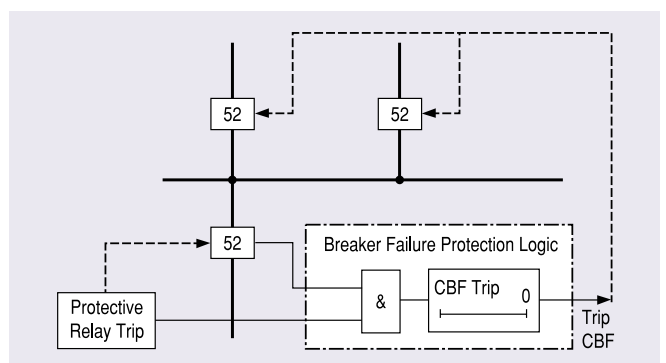

Technical Specifications

Rating

Type		Specification	
Wiring		1P3W, 3P3W, 3P4W	
Input	Frequency	60Hz/50Hz	
	Voltage	PT	110V (100V)
		GPT	190V, 190/√3V
	Current	CT	5A (Option : 1A)
		ZCT	200/1.5mA
	Control Voltage	AC/DC 110V	
	Power Consumption	Normal : Max. 30W, Operating : Max. 70W	
	Burden	PT	Max. 0.5VA
		CT	Max. 1.0VA
	Input Contact 6EA	Digital Input : AC/DC 110V/125V	
Output Contact	2EA for Power	AC 250V 16A / DC 30V 16A, Resistive Load 4000VA, 480W	
	10EA for Alarm	AC 250V 5A / DC 30V 5A, Resistive Load 1250VA, 150W	
Insulation Resistance		Over DC 500V 100MΩ	
Insulation Voltage		AC 2kV (1kV) / for 1 min	
Impulse Voltage		AC 5kV (3kV) Over 1.2 × 50μs	
Overload Withstand	Current circuit	3 In for 3 hours 20 In for 2 seconds	
	Voltage circuit	1.15 Vn for 3 hours	
Fast Transient Disturbance		Power Input 4kV Other Input 2kV (Analog input 1kV)	
ESD (Electrostatic Discharge)		Air 8kV Contact 6kV	
Operation temperature		-10°C ~ 55°C	
Storage Temperature		-25°C ~ 70°C	
Humidity		Average 30% ~ 80%	
Altitude		1000m and below	
Others		Non-impact place Non-air pollution place	
Standard		IEC 60255, IEC 61000-4, KEMC 1120	

Digital Integrated Protection & Monitoring Device

Technical Specifications

Protection function

Type	Usage	Protection		
GIPAM-2000FI	Feeder Incoming	<ul style="list-style-type: none"> · OCR (50/51) · DGR (67N) · UVR (27-1) · POR(47P) 	<ul style="list-style-type: none"> · OCGR (50/51N) · OVR (59) · R-UVR (27R) · Reclosing (79) 	<ul style="list-style-type: none"> · SGR (67G) · OVGR (64G) ³⁾ · NSOVR (47N) · Lock-out (86) ²⁾
GIPAM-2000M	Motor	<ul style="list-style-type: none"> · OCR (50/51) · DGR (67N) · NSOVR (47N) · 48/51LR 	<ul style="list-style-type: none"> · OCGR (50/51N) · NSOCR (46) · THR (49) · Lock-out (86) ²⁾ 	<ul style="list-style-type: none"> · SGR (67G) · POR (47P) · UVR (27-1)
GIPAM-2000T	Transformer	<ul style="list-style-type: none"> · DFR (87T) · OCGR (50/51N-1) · Lock-out (86) ²⁾ 	<ul style="list-style-type: none"> · OCR (50/51-1) · OCGR (50/51N-2) 	<ul style="list-style-type: none"> · OCR (50/51-2) · Inrush Detector (68) ¹⁾

Note) 1. DFR (87T) contains Inrush Detector (68).

2. Lock-out (86) can be configured as a PLC Trip Logic

3. OVGR is not connected to the CB_OFF (TRIP circuit) . (Modify the LOGIC if necessary)

Measurement function

Measurement	Display range	Accuracy (%)	Remarks
Voltage (V)	0.00V ~ 999.99kV	±0.5%	Line voltage, Phase voltage
Zero phase voltage (Vo)	0.00V ~ 999.99V	±0.5%	Vo, Vo_max
Reverse phase voltage (V2)	0.00V ~ 999.99kV	±0.5%	
Current (A)	0.00A ~ 999.99kA	±0.5%	Phase current
Zero phase current (Io)	0.00A ~ 999.99A	±0.5%	Io(In), Io(In)_max
Reverse phase current (I2)	0.00A ~ 999.99kA	±0.5%	Displayed only at M type
Phase	0.00° ~ 360.00°	±0.5%	Phase between lines, between phases, between phase and current, between currents, between Zero phase Amps and voltage
Active power (W) ¹⁾	0.00W ~ 999.99MW	±0.5%	+ : Forward, - : Reverse
Reactive power (VAR)	0.00VAR ~ 999.99MVAR	±1.0%	
Apparent power (VA)	0.00VA ~ 999.99MVA	±1.0%	
Active Energy (WH)	0.00WH ~ 9999.99MWH	±1.0%	+ : Forward, - : Reverse
Reactive energy (VARH)	0.00VARH ~ 9999.99MVARH	±1.0%	
Frequency (F)	45 ~ 65Hz	±0.5%	
Power Factor (PF)	-1.000 ~ 1.000	±1.0%	cosθ, Lead (-)/Lag(+)
Fundamental Power Factor (DPF)	-1.000 ~ 1.000	±1.0%	
Voltage harmonics (%)	0.00 ~ 100.00 ²⁾		Va(ab), Vb(bc), Vc(ca), Vo (n) of the 2 nd ~ 13 th harmonics and THD
Current harmonics (%)	0.00 ~ 100.00 ²⁾		Ia, Ib, Ic, Io(n) of 2 nd ~ 13 th harmonics and THD
Active Power Demand	0.00W ~ 999.99MW ²⁾		Total Peak Demand, Over Demand
Reactive Power Demand	0.00W ~ 999.99MVAR ²⁾		Total Peak Demand, Over Demand
Current Demand	0.3A ~ 999.99kA ²⁾		Each phase and total Peak Demand

Note) 1. Accuracy of Real power is based on the rating for PF = 1

2. Harmonics and Demand function applies only for GIPAM-2000

Communications

GIPAM-2000 provides baud rate up to 64kbps data transmission with the general RS-485 communication. In addition, RS-485/I-NET combo port and Fiber Optic (optical) port are provided, and DNP3.0 MODBUS protocol and I-NET (LSIS-dedicated) protocol are supported. The standard protocol, MODBUS protocol transmitting data at 100Mbps is applied to Ethernet communication method of GIPAM-2000

1 I-NET communication standards

I-NET is an express and high reliable communication which is designed with Custom LSI(GCV14605) ASIC Chip developed by LSIS.

- Baud rate: 250kbps
- Communication Line:
 - Low capacitance LAN Interface cable
- Communication range: Maximum 1 km
- Specification:
 - LIREV-AMEBSB 22AWG 2-pair (7/0.254TA)
- Isolation Method: Pulse Transformer
- Characteristic Impedance: 10MHz, 120Ω
- Connection Method: 4-Wire Multi-drop
- Termination: 2 Vertical 120Ω resistances are needed in the both sides of the line ends.
- Signal Modulation: Bipolar

2 DNS3.0, MODBUS / RS-485 Communication standards

- Operation mode: Differential
- Communication Range: Maximum 1.2km
- Communication Line: RS-485 shield twist 2-Pair cable
- Communication speed: Normally 19.2kbps~38.4bps
- Transmission Method: Half-Duplex
- Maximum Input/Output Voltage: -7V~+12V

3 DNS3.0, MODBUS/Optic Communication Standards (Optic Transceiver Specification)

- Wave Length: 820nm
- Fiber Size: 50/125, 62.5/125, 100/140 μ m
- Optical Connector Type: ST Type
- Optic Link Distance:
 - Depends on Data rate, Maximum 4km
 - (GIPAM-2200's Data bit rate: 9600bps ~ 230.4kbps)

4 MODBUS TCP/IP

- 100Base-TX
 - Maximum baud rate: 100Mbps
 - Topology: Star Type
 - Transmission media: UTP(CAT.5), STP(Level3)
 - Maximum transmission distance :
 - Max. 100m per segment
- UNIT ID: 255

5 Extra Communication Equipments.

Protocol Converter (GMPC)

- Converting into RS-232/485/422 common use, Ethernet
- Supporting DNP3.0, MODBUS Protocol



<GMPC-V>



<GMPC-MASTER>

6 Rear View

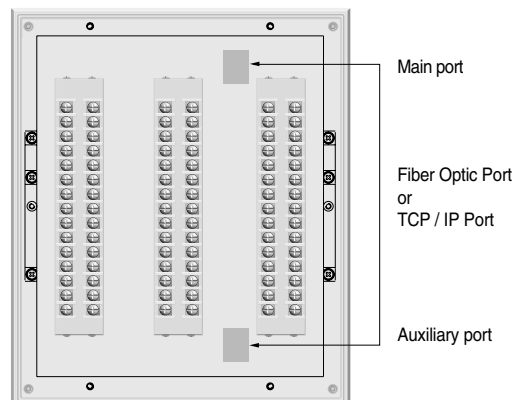

<GIPAM-2000>

Digital Integrated Protection & Monitoring Device

Characteristics

GIPAM-2000FI

Protection	Operating part		Setting range		Operating time ³⁾		Note
					Setting	Curves	
OCR (50/51)	Instantaneous	Low set	OFF, 0.5~32In/0.1In		30~250ms	Definite	
		High set					
	* Time delay	Low set	OFF, 0.10~5.00In/0.01In		0.05~1.20/0.01	Inverse	
		High set	OFF, 0.10~10.00In/0.01In		0.05~300.00s/0.01s	Definite	
OCGR (50/51N)	Instantaneous	Low set	OFF, 0.1~8.0In/0.02In		40~250ms/5ms	Definite	
		High set					
	* Time delay	Low set	OFF, 0.02~2.00In/0.01In		0.05~1.20/0.01	Inverse	
		High set	OFF, 0.1~2.00In/0.01In		0.05~300.00s/0.01s	Definite	
SGR (67G) DGR (67N)	Time delay	Zero-phases current	Grounded	OFF, 0.9~6mA/0.1mA (Ion=1.5mA)	0.05~10.00s/0.01s	Definite	*If Not use selected at the input of Zero-phase voltage, only ZCT input enables to operate (GR protection element)
			Non-grounded	OFF, 0.02~2.00Ion/0.01Ion (Ion=5A)			
		Zero-phases voltage	8~80V/1V (Von=190V, 190/√3 V)				
		Reference sensitivity Phase angle	0° ~90° /1°				
OVR (59)	* Time delay	Low set	OFF, 0.8~1.6Vn/0.01Vn		0.01~1.20/0.01	Inverse	SI, VI, DT
		High set			0.05~10.00s/0.01s	Definite	
OVGR (64G) ²⁾	Instantaneous	OFF, 0.05~0.80Von/0.01Von (0.09~1.0Von/0.01Von)		40~250ms	Definite	SI, VI, EI, DT Von=190V (in case of Von=190/√3 V)	
	Time delay	Low set	OFF, 0.05~0.20Von/0.01Von (0.09~0.4Von/0.01Von)		0.05~1.00/0.01		Inverse
		High set	OFF, 0.05~0.80Von/0.01Von (0.09~1.0Von/0.01Von)		0.05~300.00s/0.01s		Definite
UVR (27)	Time delay	-OFF, 0.20~1.00Vn/0.01Vn		0, 0.05~10.00s/0.01s	Definite		
R-UVR (27R)	Time delay	-OFF, 0.20~1.00Vn/0.01Vn		0, 0.05~10.00s/0.01s	Definite	B-bus R-phase voltage detection	
NSOVR (47N)	Time delay	OFF, 0.05~1.00Vn/0.01Vn		0.05~10.00s/0.01s	Definite	Unbalance (%) = Reverse portion of unbalanced 3-phase circuits Normal portion of unbalanced 3-phase circuits × 100	
POR (47P)	Time delay	OFF, 5~100%/1%		0.05~10.00s/0.01s	Definite	Unbalance (%) = $\frac{V_{max}-V_{min}}{V_{average}} \times 100$	
Reclosing element	Reclosing protective elements		Prepared Time	Dead Time	Reclaim Time	Reclosing times	
Reclosing (79)	OCR, OCGR, SGR, DGR		OFF, 0.0~300.0s / 0.1s	0.2~300.0s / 0.1s	0.0~300.0s / 0.1s	1~5 times (1 time for Instantaneous Trip)	

Note) 1. * Operating Delay time (C) can be set: 0.00 ~ 10.00s/0.01s (applies only for inverse time)
 2. OVGR is not connected to the CB_OFF (TRIP circuit) . (Modify the LOGIC if necessary)
 3. The operating time is based on 60Hz.

GIPAM-2000M

Protection	Operating part		Setting range		Operating time ²⁾		Note	
					Setting	Curves		
OCR (50/51)	Instantaneous	Low set	OFF, 0.5-32In/0.1In		30~250ms	Definite		
		High set						
	* Time delay	Low set	OFF, 0.10~5.00In/0.01In		0.05~1.20/0.01	Inverse		SI, VI, EI, LI, DT, Kepco SI, Kepco VI
		High set	OFF, 0.10~10.00In/0.01In		0.05~300.00s/0.01s	Definite		
OCGR (50/51N)	Instantaneous	Low set	OFF, 0.1-8.0In/0.02In		40~250ms/5ms	Definite		
		High set						
	* Time delay	Low set	OFF, 0.02~2.00In/0.01In		0.05~1.20/0.01	Inverse		SI, VI, EI, LI, DT, Kepco SI, Kepco VI
		High set	OFF, 0.1~2.00In/0.01In		0.05~300.00s/0.01s	Definite		
SGR (67G) DGR (67N)	Time delay	Zero-phases current	Grounded	OFF, 0.9~6mA/0.1mA (I _{on} =1.5mA)		0.05~10.00s/0.01s	Definite	*If Not use selected at the input of Zero-phase voltage, only ZCT input enables to operate (GR protection element)
			Non-grounded	OFF, 0.02~2.00In/0.01In (I _{on} =5A)				
		Zero-phases voltage	8~80V/1V (V _{on} =190V, 190/√3 V)					
		Reference sensitivity Phase angle	0° ~90° /1°					
NSOCR (46)	Instantaneous		OFF, 0.1~2.0In/0.02In		30~250ms/5ms	Definite	SI, VI, EI, LI, DT	
	* Time delay		OFF, 0.08~1.00In/0.01In		0.05~1.00/0.01	Inverse		
					0.05~10.00s/0.01s	Definite		
POR (47P)	Time delay		OFF, 5~100%/1%		40~250ms	Definite	Unbalance (%) = $\frac{V_{max}-V_{min}}{V_{average}} \times 100$	
Stall/Lock (48/51LR)	Time	Stall Current	OFF, 0.20~10.00In/0.01In		0.05~300.00s/0.01s	Definite	Starting time set 1~300s/0.1s	
		Lock Current	OFF, 0.20~10.00In/0.01In		0.05~1.00/0.01	Inverse (VI, EI)		
THR (49)	Hot		OFF, 0.20~5.0In/0.01In		Thermal time constant 0.5~60min/0.5min	$t = \tau \cdot \ln \frac{I^2 - I^2}{I^2 - (k \cdot I_B)^2}$	t : Operating time k : multiple factor (0.5~1.5/0.05) τ : Thermal time constant	
	Cold					$t = \tau \cdot \ln \frac{I^2}{I^2 - (k \cdot I_B)^2}$		
NSOVR (47N)	Time delay		OFF, 0.05~1.00Vn/0.01Vn		0.05~10.00s/0.01s	Definite	Unbalance (%) = Reverse portion of unbalanced 3-phase circuits $\frac{\text{Normal portion of unbalanced3-phase circuits}}{\text{Normal portion of unbalanced3-phase circuits}} \times 100$	
UVR (27)	Time delay		-OFF, 0.20~1.00Vn/0.01Vn		0, 0.05~10.00s/0.01s	Definite		

Note) 1. * Operating Delay time (C) can be set: 0.00 ~ 10.00s/0.01s (applies only for inverse time)
2. The operating time is based on 60Hz.

Digital Integrated Protection & Monitoring Device

Characteristics

GIPAM-2000T

Protection	Setting range		Delay time	Note
* DFR (87T)	Low set	Id : 0.2~1.0In/0.1In Slope 1 : 0.15~1.00/0.01 Slope 2 : 0.15~1.00/0.01 Knee Point : 1.0~20.0In/0.1In	Inst., 0.05~10.00s/0.01s	Inst.: less than 50ms
		Inrush Inhibit : 5~50%/1%	Inrush Inhibit : 0.02~60.00/0.01s	
	High set	Id : 2.0~32In/0.1In	Instantaneous: less than 40ms	

Protection	Time		Setting range	Delay time		Note	
				Setting	Curves		
OCR (50/51-1)	Instantaneous	Low set	OFF, 0.5~32In/0.1In	30~250ms/5ms	Definite		
		High set					
	* Time delay	Low set	OFF, 0.10~5.00In/0.01In	0.05~1.20/0.01	Inverse		SI, VI, EI, LI, DT, Kepco SI, Kepco VI
		High set	OFF, 0.10~10.00In/0.01In	0.05~300.00s/0.01s	Definite		
OCR (50/51-2)	Instantaneous	Low set	OFF, 0.5~32In/0.01In	30~250ms/5ms	Definite		
		High set					
	* Time delay	Low set	OFF, 0.10~5.00In/0.01In	0.05~1.20/0.01	Inverse		SI, VI, EI, LI, DT, Kepco SI, Kepco VI
		High set	OFF, 0.10~10.00In/0.01In	0.05~300.00s/0.01s	Definite		
OCR (50/51-3)	Instantaneous	Low set	OFF, 0.5~32In/0.01In	30~250ms/5ms	Definite		
		High set					
	* Time delay	Low set	OFF, 0.10~5.00In/0.01In	0.05~1.20/0.01	Inverse		SI, VI, EI, LI, DT, Kepco SI, Kepco VI
		High set	OFF, 0.10~10.00In/0.01In	0.05~300.00s/0.01s	Definite		
OCGR (50/51N-1)	Instantaneous	Low set	OFF, 0.1~8.0In/0.02In	40~250ms	Definite		
		High set					
	* Time delay	Low set	OFF, 0.02~2.00In/0.01In	0.05~1.20/0.01	Inverse		SI, VI, EI, LI, DT, Kepco SI, Kepco VI
		High set	OFF, 0.1~2.00In/0.01In	0.05~300.00s/0.01s	Definite		
OCGR (50/51N-2)	Instantaneous	Low set	OFF, 0.1~8.0In/0.02In	40~250ms	Definite		
		High set					
	* Time delay	Low set	OFF, 0.02~2.00In/0.01In	0.05~1.20/0.01	Inverse		SI, VI, EI, LI, DT, Kepco SI, Kepco VI
		High set	OFF, 0.1~2.00In/0.01In	0.05~300.00s/0.01s	Definite		

Note) 1.*Operating Delay time (C) can be set: 0.00 ~ 10.00s/0.01s (applies only for inverse time)
2. OCR(50/51-3) and OCGR(50/51N-2) are models for three winding.

Time Characteristic Curves

Standard Inverse Time-SI

Operating time(t)

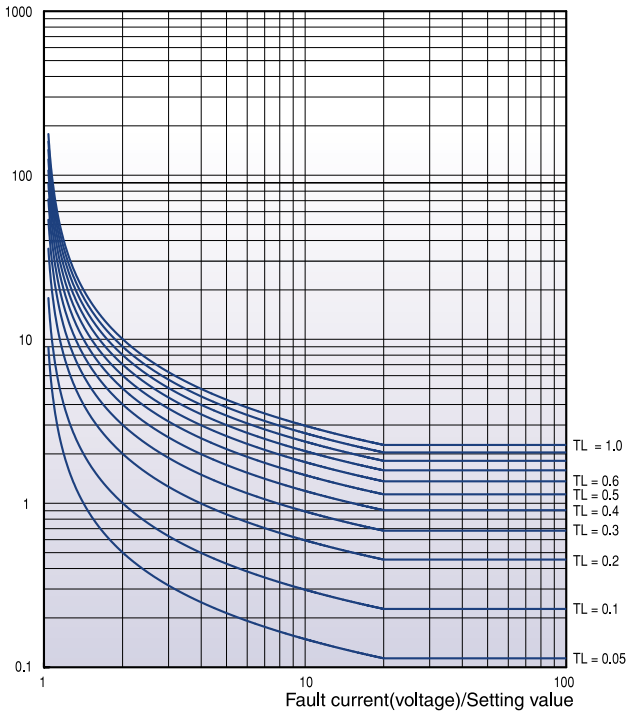

- **Application : OCR (50/51)
OCGR (50/51N)
OVGR (64)
NSOCR (46)**

$$t = \frac{0.14}{(I/I_s)^{0.02-1}} \times TL + C$$

- Time lever (TL) : 0.05~1.2
(OVGR
NSOCR } TL: 0.05~1.0)

• Relay constant C: 0

• Operation Delay Time: 0.00~10.00s/0.01s
(OCR, OCGR, NSOCR)

Very Inverse Time-VI

Operating time(t)

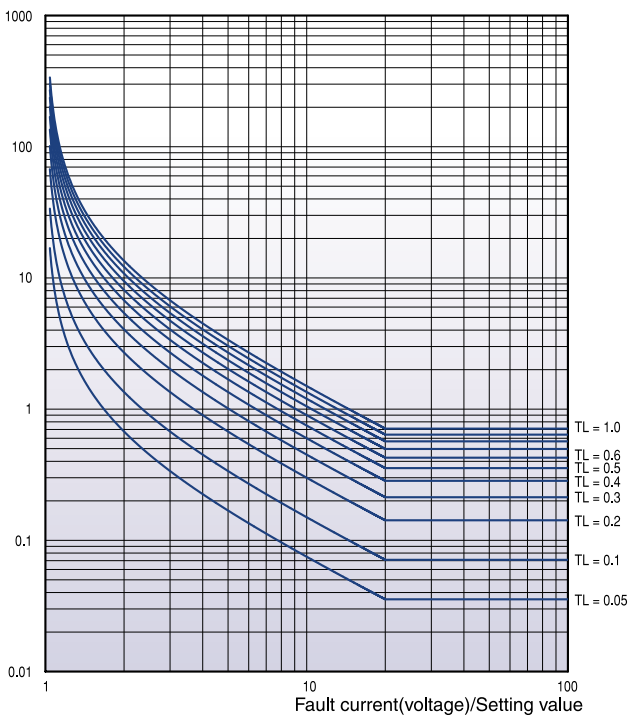

- **Application : OCR (50/51)
OCGR (50/51N)
OVGR (64)
NSOCR (46)
Locked Rotor (51LR)**

$$t = \frac{13.5}{(I/I_s)^{-1}} \times TL + C$$

- Time lever (TL) : 0.05~1.2
(OVGR
NSOCR
Locked Rotor } TL: 0.05~1.0)

• Relay constant C: 0

• Operation Delay Time: 0.00~10.00s/0.01s
(OCR, OCGR, NSOCR)

Time Characteristic Curves

Extremely Inverse Time-EI

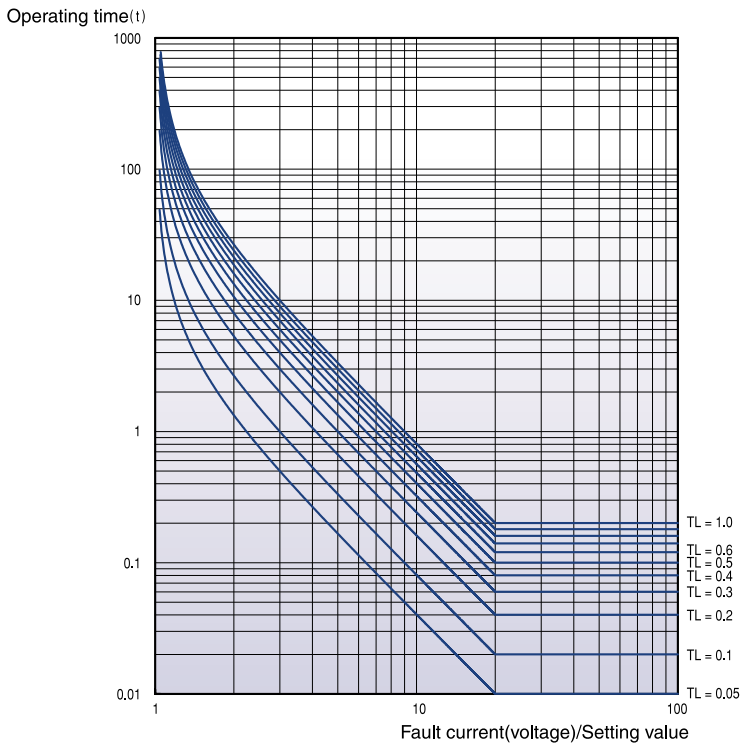

- Application : OCR (50/51)
OCGR (50/51N)
OVGR (64)
NSOCR (46)
Locked Rotor (51LR)

$$t = \frac{80}{(I/I_s)^2 - 1} \times TL + C$$

- Time lever (TL) : 0.05~1.2

}	OVGR	TL: 0.05~1.0
	NSOCR	
	Locked Rotor	
- Relay constant C: 0
- Operation Delay Time: 0.00~10.00s/0.01s
(OCR, OCGR, NSOCR)

Long Inverse Time-LI

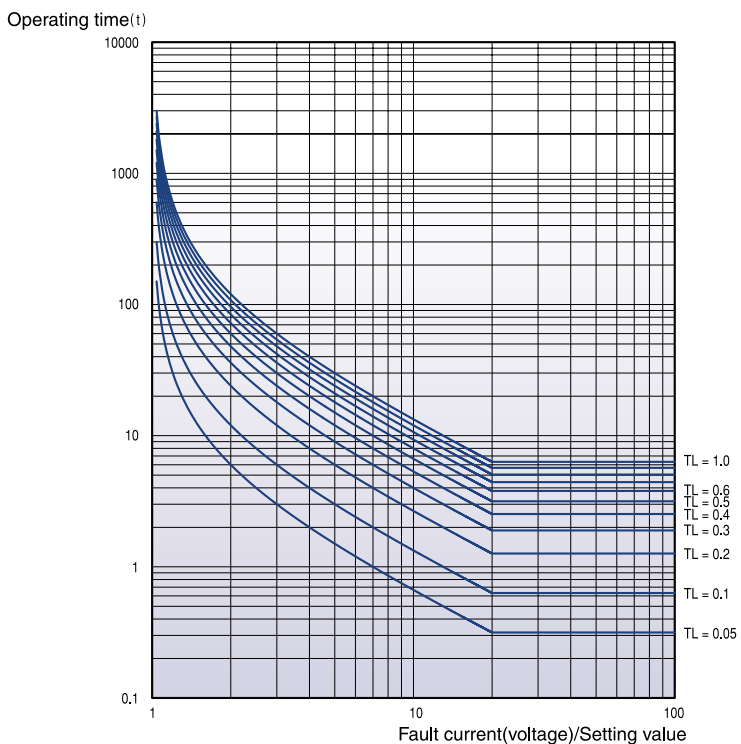

- Application : OCR (50/51)
OCGR (50/51N)
NSOCR (46)

$$t = \frac{120}{(I/I_s) - 1} \times TL + C$$

- Time lever TL: 0.05~1.2
(NSOCR (TL): 0.05~1.0)
- Relay constant C: 0
- Operation Delay Time: 0.00~10.00s/0.01s
(NSOCR)

Thermal Curve

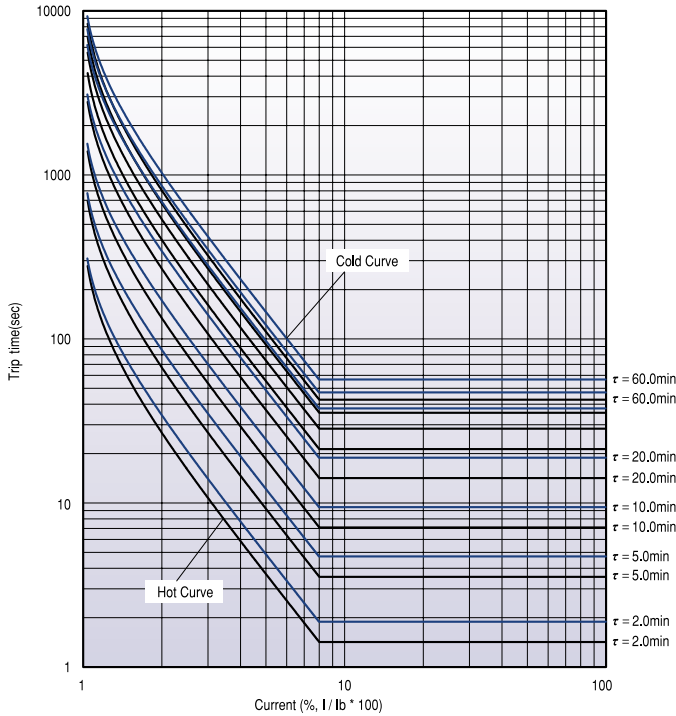

• Application : THR (49)

HOT
$$t = \tau_h \cdot \ln \frac{I^2 - I_P^2}{I^2 - (k \cdot I_B)^2}$$

$$\tau_h = 2.0 \sim 60.0 \text{min}$$

COLD
$$t = \tau_c \cdot \ln \frac{I^2}{I^2 - (k \cdot I_B)^2}$$

$$\tau_c = 2.0 \sim 60.0 \text{min}$$

$$\left(\begin{array}{l} I_P = 0.5 \\ k = 1 \\ I_B = 1 \end{array} \right)$$

- I_P : Fault full load current
- I_B : Rating load current
- k : Overload constant
- I : Fault current
- τ_h (τ heating)
- τ_c (τ cooling)

• Application : SGR (67G) DGR(67N)

- (a) Pick-up $I_o \angle$:
323° ~ 127°
- (b) Drop-out $I_o \angle$:
137° ~ 313°

$V_o > V_{os}$
 $I_o > I_{os}$
 $RCA - 87^\circ \leq \phi(V_o) - \phi(I_o) \leq RCA + 87^\circ$

• RCA : Relay Characteristic Angle

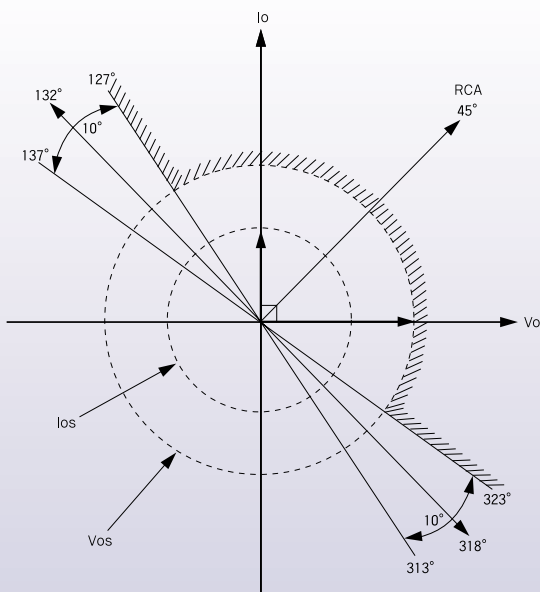

Ratio Differential Curve

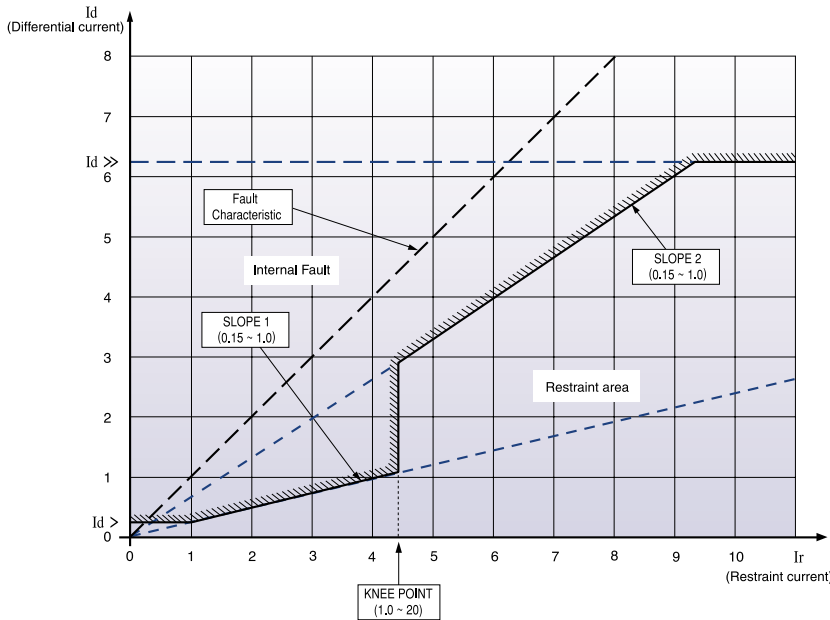

• **Application : DFR (87T-P)**

$$I_d = I_{\text{differential}} = |\bar{I}_1 - \bar{I}_2| \text{ (Vector sum.)}$$

$$I_r = I_{\text{restraint}} = |I_1| + |I_2| \text{ (Scalar sum.)}$$

$$\text{SLOPE} = \left[\frac{I_d}{I_r} \right]$$

Fault Characteristic : ($I_{1st} = I_f$, $I_{2nd} = 0$)

I_d : Differential current

I_r : Restraining current

$I_d >$: Time delay differential current
(Low set: 0.2~1.0)

$I_d >>$: Instantaneous differential current
(High set: 2.0~32.0)

Ground Ratio Differential Curve

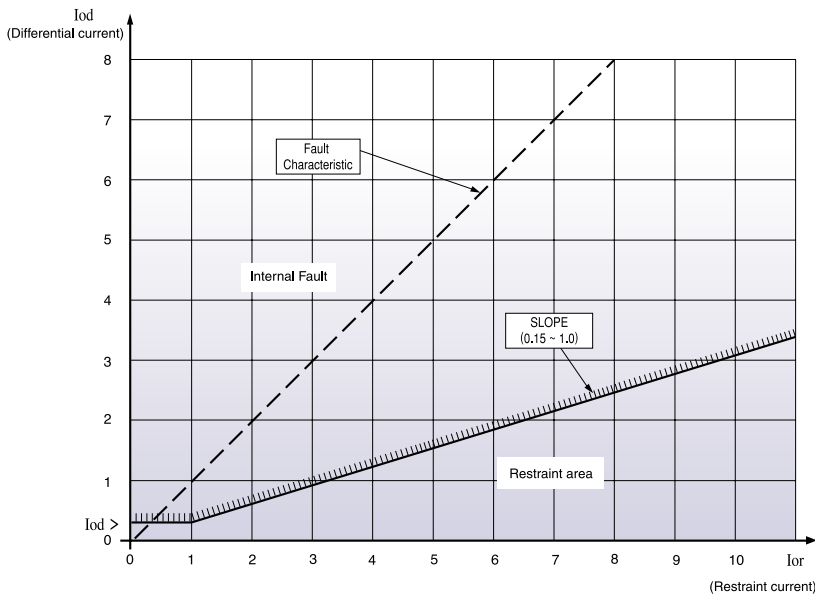

• **Application : DFR (87T-G)**

$$I_{od} = |3\bar{I}_o - \bar{I}_g| \text{ (Vector sum.)}$$

$$I_{or} = |3I_o| + |I_g| \text{ (Scalar sum.)}$$

$$\text{SLOPE} = \left[\frac{I_{od}}{I_{or}} \right]$$

Fault Characteristic ($I_{1st} = I_f$, $I_{2nd} = 0$)

I_{od} : Zero-phase differential current

I_{or} : Zero-phase restraining current

$I_{od} >$: Time delay zero-phase differential current
(0.05 ~ 1.00)

Wirings

GIPAM-2000FI/M (3P3W)

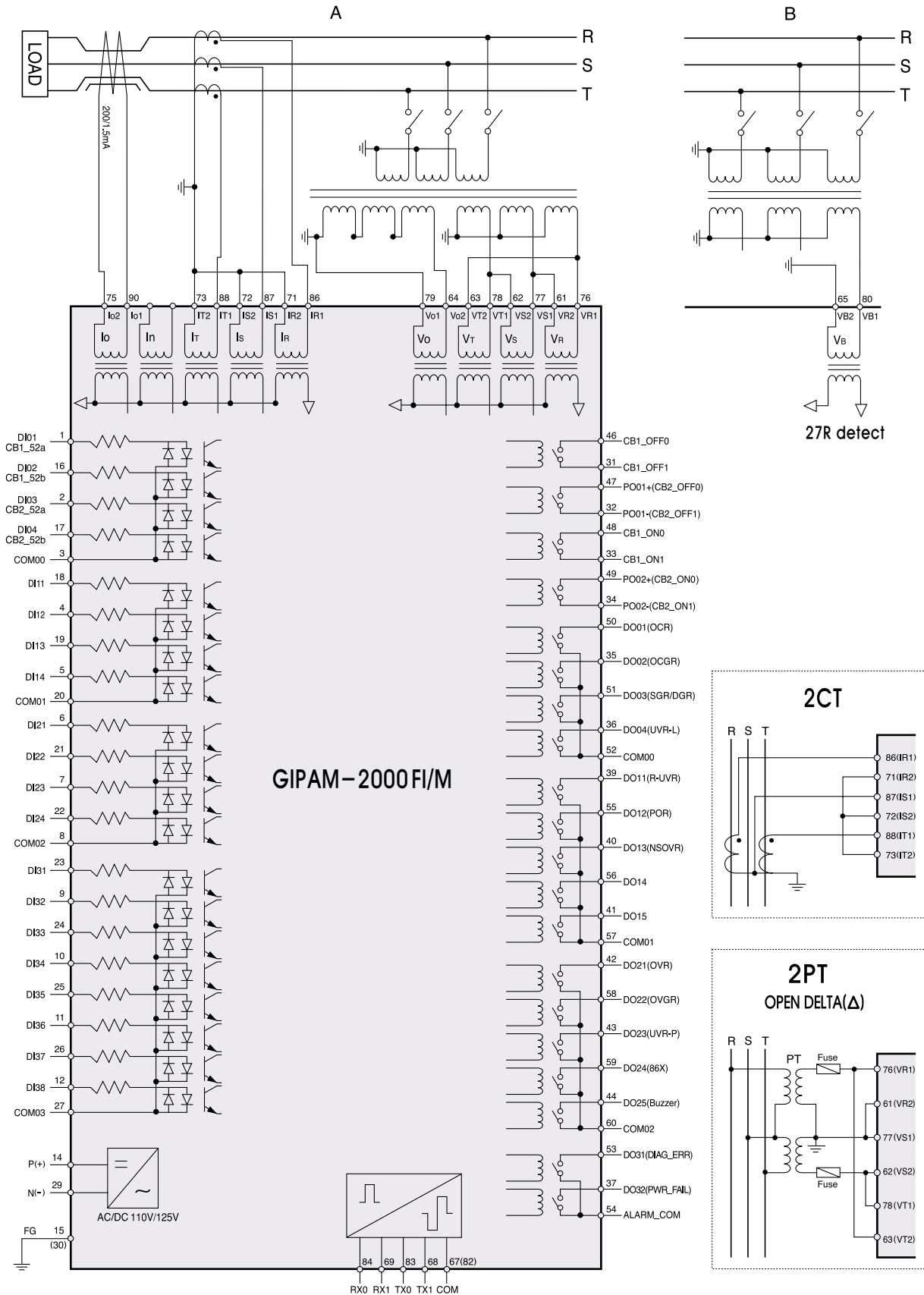

GIPAM-2000FI/M

A

B

27R detect

2CT

2PT
OPEN DELTA(Δ)

Digital Integrated Protection & Monitoring Device

Wirings

GIPAM-2000FI/M (3P4W)

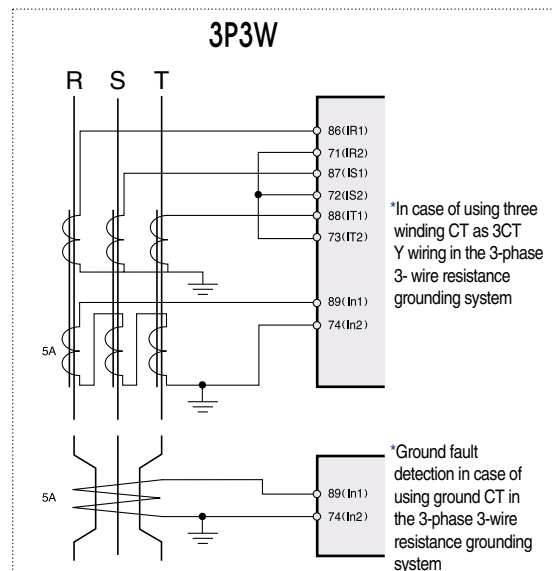
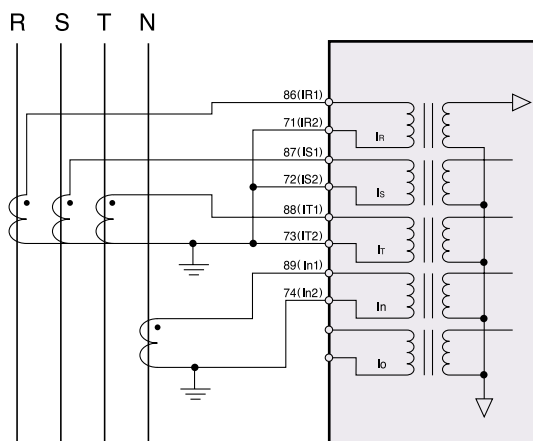
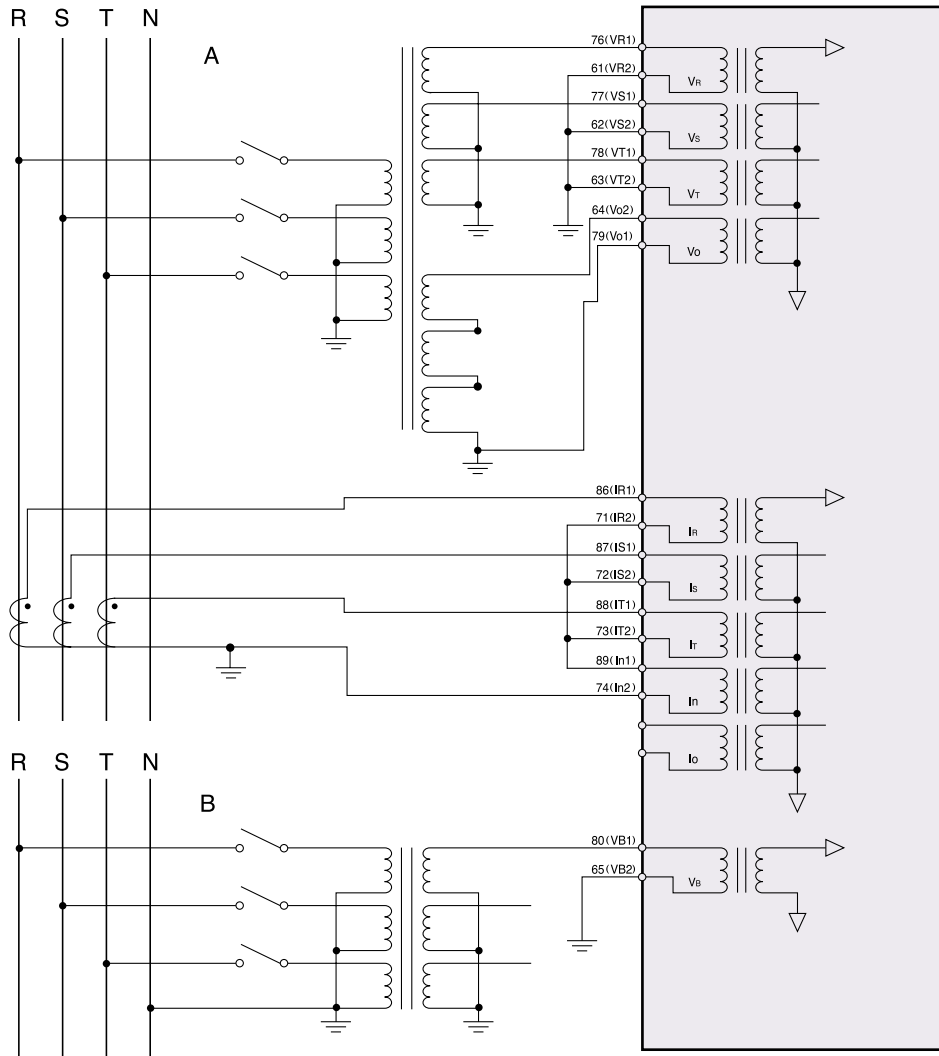

* In case of using a separate CT for the neutral point

GIPAM-2000T (for two winding)

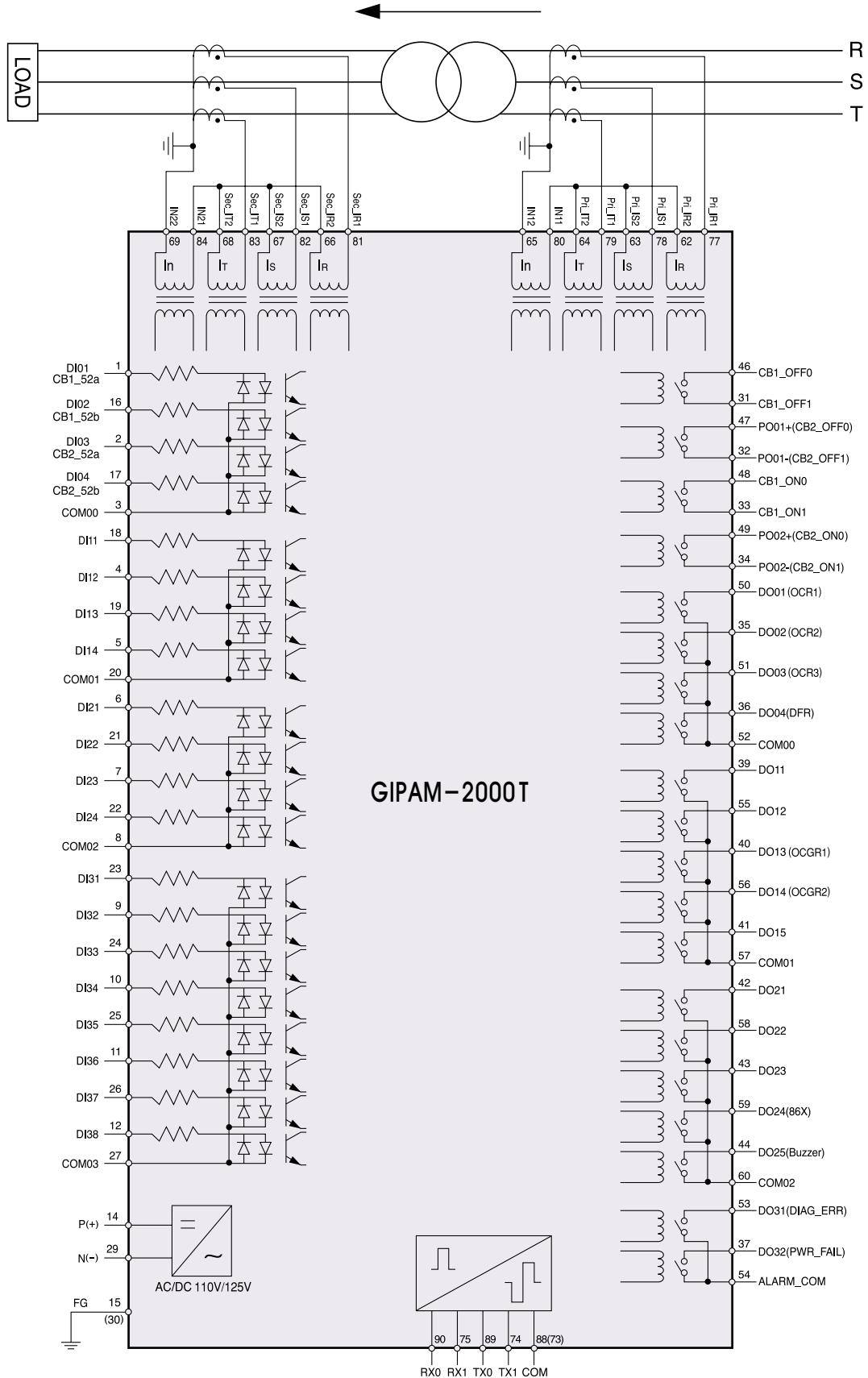

Digital Integrated Protection & Monitoring Device

Wirings

GIPAM-2000T (for three winding)

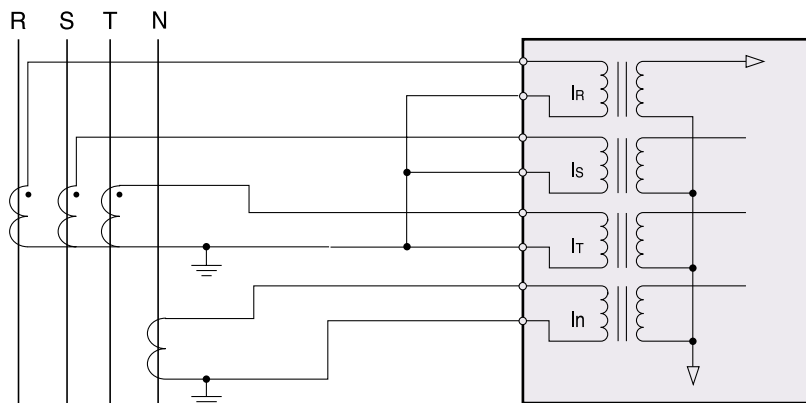
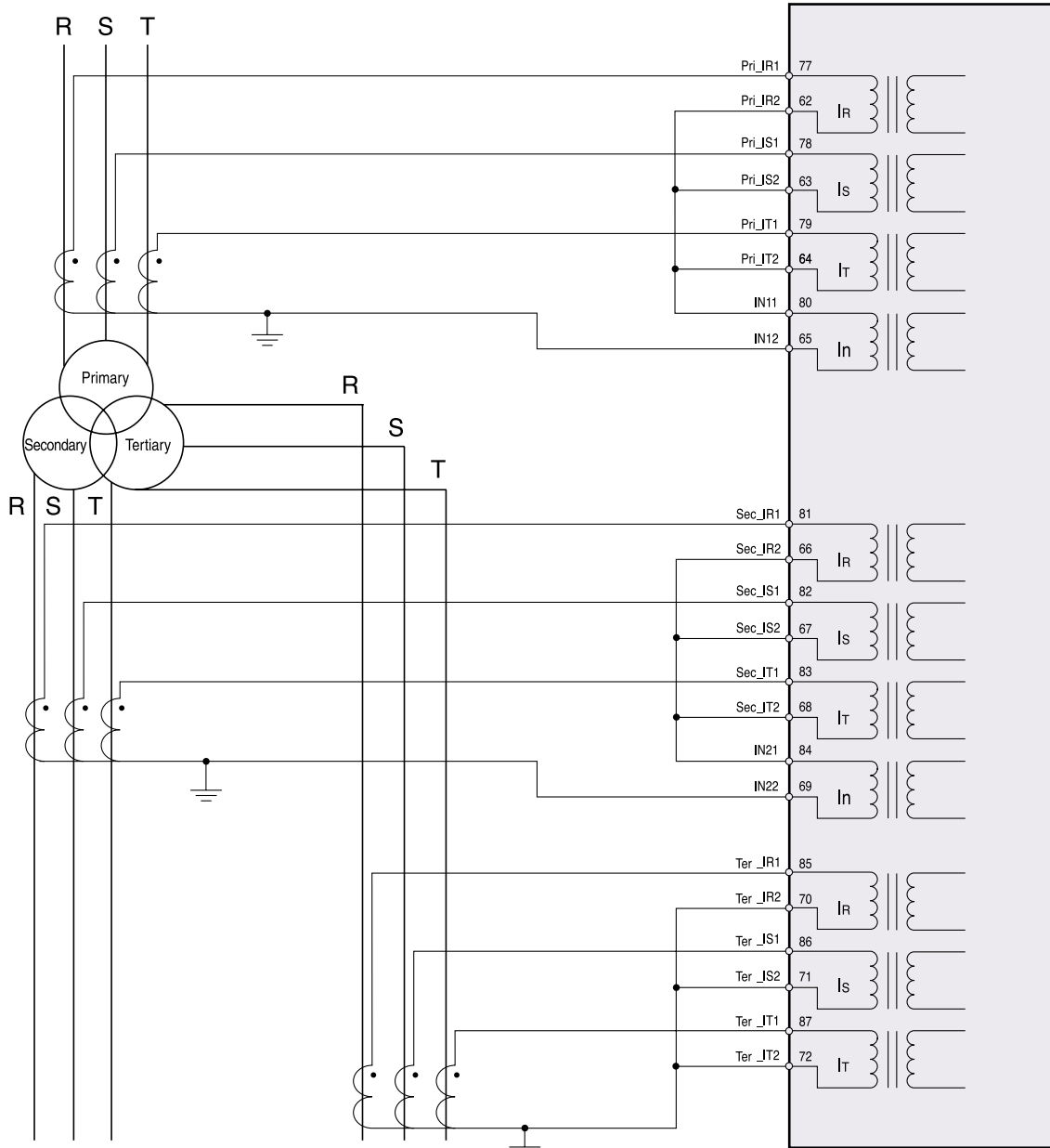

* In case of using a separate CT for the neutral point (primary, secondary and tertiary all possible)

Contact Usage

GIPAM-2000FI/M

76	VR1	VR2	61
77	VS1	VS2	62
78	VT1	VT2	63
79	Vo1	Vo2	64
80	VB1	VB2	65
81	BLANK	BLANK	66
82	COM	COM	67
83	TX0	TX1	68
84	RX0	RX1	69
85	BLANK	BLANK	70
86	IR1	IR2	71
87	IS1	IS2	72
88	IT1	IT2	73
89	In1	In2	74
90	Io1	Io2	75

46	CB1_OFF0	CB1_OFF1	31
47	PO01+	PO01-	32
48	CB1_ON0	CB1_ON1	33
49	PO02+	PO02-	34
50	DO01	DO02	35
51	DO03	DO04	36
52	COM00	DO32	37
53	DO31	BLANK	38
54	ALM.COM	DO11	39
55	DO12	DO13	40
56	DO14	DO15	41
57	COM01	DO21	42
58	DO22	DO23	43
59	DO24	DO25	44
60	COM02	BLANK	45

16	DI02	DI01	1
17	DI04	DI03	2
18	DI11	COM00	3
19	DI13	DI12	4
20	COM01	DI14	5
21	DI22	DI21	6
22	DI24	DI23	7
23	DI31	COM02	8
24	DI33	DI32	9
25	DI35	DI34	10
26	DI37	DI36	11
27	COM03	DI38	12
28	BLANK	BLANK	13
29	POWER(-)	POWER(+)	14
30	FG	FG	15

Input / Output

Terminal description	Terminal No.	Usage (default setting)	Usage (for change)	Remarks
DI01	1	CB1 status input (52a)	Unchangeable	
DI02	16	CB1 status input (52b)		
DI03	2	General DI	CB2 status input (52a)	Terminal No. Used as CB2 state input terminal when PO is set for TRIP in TRIP logic.
DI04	17	General DI	CB2 status input (52b)	
DI11	18	General DI	Input for 63CBI	Must be wired when selecting 79 (Reclosing)
DI12	4	General DI	Input for 43RC	
DI13	19	General DI	General DI	
DI14	5	General DI	Ext. Reclose Initiate output	79 sequence start at Logical High Input
DI21-DI38		General DI	General DI	Used as general Digital Input contact such as Switchgear Interlock Breaker Interlock, D / S state and E / S state,
CB1_OFF0	46	CB1 OFF output	Unchangeable	OVGR is not connected to the CB_OFF (TRIP circuit) . (Modify the LOGIC if necessary)
CB1_OFF1	31			
CB1_ON0	48	CB1 ON output	CB2 OFF output	Function as CB2 only when PO is set for TRIP in TRIP logic.
CB1_ON1	33			
PO01+	47	POWER OUT 1 output	CB2 ON output	
PO01 -	32			
PO02+	49	POWER OUT 2 output	CB2 OFF output	
PO02 -	34			
DO01	50	50/51 (OCR)	General DO	50/51 (OCR)
DO02	35	50/51N (OCGR)	General DO	50/51N (OCGR)
DO03	51	67G/N (SGR/DGR)	General DO	67G/N (SGR/DGR)
DO04	36	27 (UVR-Latch)	General DO	27 (UVR-Latch)
DO11	39	27R (R-UVR)	79 Ready	46 (NSOCR)
DO12	55	47P (POR)	79 Success	47P (POR)
DO13	40	47N (NSOVR)	79 Fail	47N (NSOVR)
DO14	56	General DO	79 Process	49 (THR)
DO15	41	General DO	79 Cancel	48/51LR
DO21	42	59 (OVR)	General DO	General DO
DO22	58	64 (OVGR)	General DO	General DO
DO23	43	27 (UVR-Pulse)	General DO	27 (UVR-Pulse)
DO24	59	86X (Lock-out)	General DO	86X (Lock-out)
DO25	44	BUZZER	General DO	BUZZER
DO31	53	DIAG_ERR	General DO	Terminal for self-diagnostic alarm
DO32	37	PWR_FAIL	General DO	Terminal for power supply problem alarm

* M type output contacts (Default): can be used as General DO

Digital Integrated Protection & Monitoring Device

Contact Usage

GIPAM-2000T

76	FG	FG	61
77	Pri_IR1	Pri_IR2	62
78	Pri_IS1	Pri_IS2	63
79	Pri_IT1	Pri_IT2	64
80	IN11	IN12	65
81	Sec_IR1	Sec_IR2	66
82	Sec_IS1	Sec_IS2	67
83	Sec_IT1	Sec_IT2	68
84	IN21	IN22	69
85	Ter_IR1	Ter_IR2	70
86	Ter_IS1	Ter_IS2	71
87	Ter_IT1	Ter_IT2	72
88	COM	COM	73
89	TX0	TX1	74
90	RX0	RX1	75

46	CB1_OFF0	CB1_OFF1	31
47	PO01+	PO01-	32
48	CB1_ON0	CB1_ON1	33
49	PO02+	PO02-	34
50	DO01	DO02	35
51	DO03	DO04	36
52	COM00	DO32	37
53	DO31	BLANK	38
54	ALM_COM	DO11	39
55	DO12	DO13	40
56	DO14	DO15	41
57	COM01	DO21	42
58	DO22	DO23	43
59	DO24	DO25	44
60	COM02	BLANK	45

16	DI02	DI01	1
17	DI04	DI03	2
18	DI11	COM00	3
19	DI13	DI12	4
20	COM01	DI14	5
21	DI22	DI21	6
22	DI24	DI23	7
23	DI31	COM02	8
24	DI33	DI32	9
25	DI35	DI34	10
26	DI37	DI36	11
27	COM03	DI38	12
28	BLANK	BLANK	13
29	POWER(-)	POWER(+)	14
30	FG	FG	15

Pri : Primary (for primary winding)
 Sec : Secondary (for secondary winding)
 Ter : Tertiary (for tertiary winding)

Input / Output

Terminal description	Terminal No.	Usage (default setting)	Usage (for change)	Remarks
DI01	1	CB1 status input (52a)	Unchangeable	
DI02	16	CB1 status input (52b)		
DI03	2	General DI	CB2 status input (52a)	Terminal No. Used as CB2 state input terminal when PO is set for TRIP in TRIP logic
DI04	17	General DI	CB2 status input (52b)	
DI11-DI38		16 General DI	16 General DI	Used as general Digital Input contact such as Switchgear Interlock Breaker Interlock, D / S state and E / S state,
CB1_OFF0	46	CB1 OFF output	Unchangeable	
CB1_OFF1	31			
CB1_ON0	48	CB1 ON output		
CB1_ON1	33			
PO01+	47	POWER OUT 1 output	CB2 OFF output	Function as CB2 only when PO is set for TRIP
PO01 -	32			
PO02+	49	POWER OUT 2 output	CB2 ON output	
PO02 -	34			
DO01	50	OCR1 ALARM	General DO	
DO02	35	OCR2 ALARM	General DO	
DO03	51	OCR3 ALARM	General DO	
DO04	36	DFR ALARM	General DO	
DO11	39	General DO	General DO	
DO12	55	General DO	General DO	
DO13	40	OCGR1 ALARM	General DO	
DO14	56	OCGR2 ALARM	General DO	
DO15	41	General DO	General DO	
DO21	42	General DO	General DO	
DO22	58	General DO	General DO	
DO23	43	General DO	General DO	
DO24	59	86X (Lock-out)	General DO	
DO25	44	BUZZER	General DO	
DO31	53	DIAG_ERR	General DO	Terminal for self-diagnostic alarm
DO32	37	PWR_FAIL	General DO	Terminal for power supply problem alarm

Dimension

GIPAM-2000

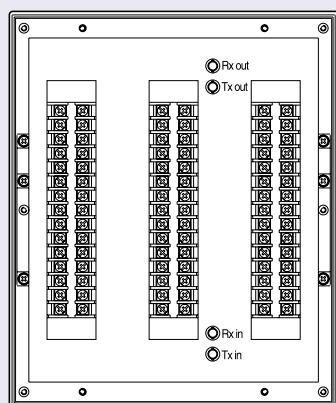
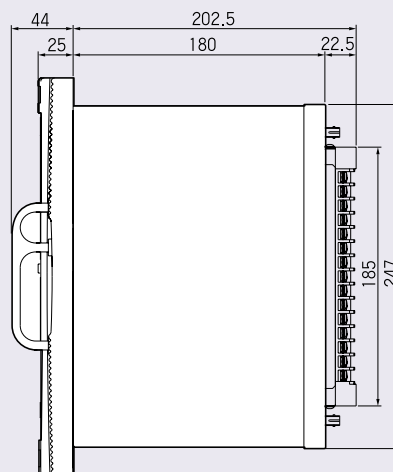
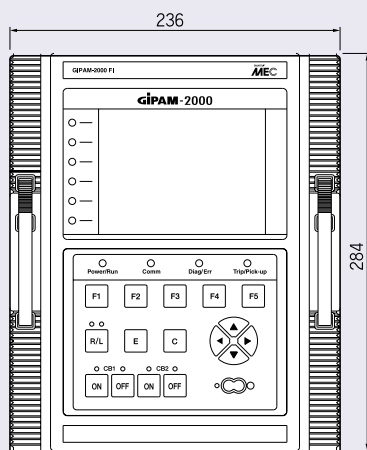
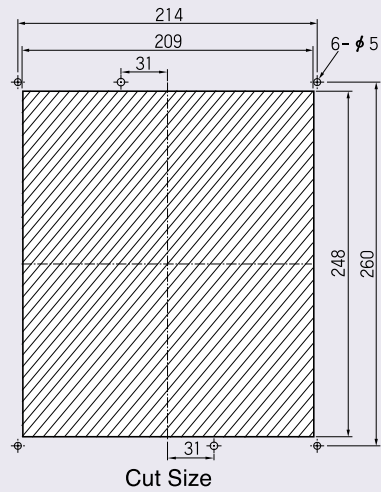
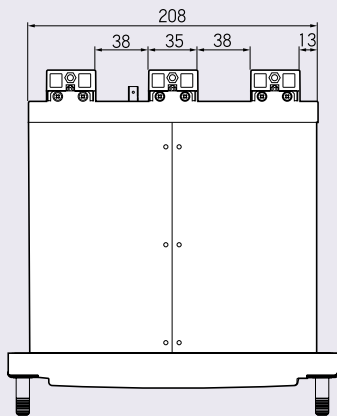

Digital Integrated Protection & Monitoring Device

Ordering

GIPAM - 2000

FI		RS		D		60Hz		5A	
Protection Usage		Communication		Protocol		Frequency		Input	
FI	Feeder/Incoming	RS	RS-485	D	DNP3.0	60Hz		5A	
M	Motor	OP	Fiber-Optic/RS-485	M	MODBUS	50Hz		1A*	
T	Transformer	IN	I-NET	I	I-NET				
		TE	100/10 Base-T Ethernet						
		-	Non						

GIPAM-OPTO MASTER

IrDA Serial Port(Optional)
PC Interface Software

* Contact your LS sales representative for 1A specification.

GIPAM-115



Digital Integrated Protection & Monitoring Device

GIPAM-115

Digital Integrated Protection & Monitoring Equipment

GIPAM is a multifunction, microprocessor-based protection equipment suitable for all types of applications such as distribution feeders.

It can be also be used for management and backup protection of buses, transformers, and power lines.

Drawout structure for panel-flush mounting

User-friendly front panel to monitor, program, and test the GIPAM

Data communication with a host computer



IEC 60255, KEMC 1120, JEC 174C
ISO 9001, ISO 14001





Contents :

Features	N-3-4
Technical specifications	N-3-6
Communications	N-3-8
External & MMI	N-3-9
Operation curves	N-3-10
Wirings	N-3-12
Ordering & Dimension	N-3-15



Digital Integrated Protection & Monitoring Device

Features

GIPAM

Digital Integrated Protection & Monitoring Equipment

GIPAM is a multifunction, microprocessor-based protection equipment suitable for all types of applications such as distribution feeders.

It can also be used for management and backup protection of buses, transformers, and power lines.

Drawout structure for panel mounting

User-friendly front panel to monitor, program, and test the GIPAM

Data communication with a host computer





■ Protection

- **Multi-functions offering a wide choice of protective options**

OCR, 50/51
 OCGR, 50/51N
 OVR, 59
 UVR, 27
 OVGR, 64G
 SGR, 67G
 POR, 47

- **Broad setting ranges**

- **All types of curves provided**

SI, Standard inverse time delay
 VI, Very inverse time delay
 EI, Extremely inverse time delay
 LI, Long inverse time delay
 DT, Definite time delay

- **Logging of fault current and voltage for each phase**



■ Metering and Monitoring

- **Acquisition, visualization and storage of electrical data**

Volt, Amper, Watt, Zero phase volt, VAR, Watthour
 VARH, Power factor, Frequency, Cumulative operating time
 Number of operations closing and opening status
 Digital displaying of each fault information

- **Broad setting ranges**

- **Displaying status via digital LCD and analog Bar graph for better visualization**

- **Offering operation reliability**

Continuous monitoring and autodiagnosics systems
 through microprocessor technology

■ Communication

- Modbus/RS-485
- I-NET / LS customized protocol

Digital Integrated Protection & Monitoring Device

Technical specifications

Rating

Type		Specification	
Wiring		1P2W, 1P3W, 3P3W, 3P4W	
Input	Frequency	60Hz/50Hz	
	Voltage	PT	110V/100V
		GPT	190V
	Current	CT	5A
		ZCT	200/1.5mA
	Control Voltage	AC/DC 110V or DC 110/125V (or DC 110V ±20%)	
	Power Consumption	Steady: 30W Max. Operating: 70W Max.	
	Burden	PT	Max. 0.5VA
		CT	Max. 1.0VA
Input Contact 3EA	Digital Input : AC/DC 110V		
Output Contact	2EA for Power	AC 250V 16A / DC 30V 16A, Resistive Load 4000VA, 480W	
	8EA for Alarm (7a 1c)	AC 250V 5A / DC 30V 5A, Resistive Load 1250VA, 150W	
Insulation Resistance		Over DC 500V 100MΩ	
Insulation Voltage		AC 2kV (1kV) / for 1 min	
Impulse Voltage		AC 5kV (3kV) Over 1.2 × 50μs	
Overload Withstand	Current circuit	2 In for 3 hours 20 In for 2 seconds	
	Voltage circuit	1.15 Vn for 3 hours	
Fast Transient Disturbance		Power Input 4kV Other Input 2kV (Analog input 1kV)	
ESD (Electrostatic Discharge)		Air 8kV Contact 6kV	
Operation temperature		-10°C ~ 55°C	
Storage Temperature		-25°C ~ 70°C	
Humidity		Average 30% ~ 80%	
Altitude		1000m and below	
Others		Non-impact place Non-air pollution place	
Standard		IEC 60255, IEC 61000-4, KEMC 1120	
Dimension (W × H × D)		437 × 210 × 165 mm	
Weight		10.5kg	

Protection functions

Functions	Operation element	Setting range	Operating time characteristics		Remarks
			Setting range	Characteristics	
OCR [50/51]	Instantaneous	OFF, 2~24In / 1In	0.04~60.0s / 0.01s	Definite time	
	Time-delay	OFF, 0.2~10.0In / 0.1In	0.05~1.20 / 0.01	Definite time 3 types Inverse time 4 types	D2, D4, D8 SI, VI, EI, LI
OCGR [50/51N]	Instantaneous	OFF, 0.5~8.0In / 0.5In	0.04~60.0s / 0.01s	Definite time	Block time : 0.1~60.0s/0.1s
	Time-delay	OFF, 0.1~0.5In / 0.02In	0.05~1.20 / 0.01	Definite time 3 types Inverse time 4 types	
OVR [59]	Time-delay(high)	OFF, 0.80~1.60Vn / 0.02Vn	0.1~60.0s / 0.01s	Definite time	
	Time-delay(Low)	OFF, 0.80~1.60Vn / 0.02Vn	0.1~60.0s / 0.01s	Definite time	
UVR [27]	Time-delay(high)	OFF, 0.20~0.90Vn / 0.02Vn	0.1~60.0s / 0.01s	Definite time	Outage lock : (below 15V)
	Time-delay(Low)	OFF, 0.20~0.90Vn / 0.02Vn	0.1~60.0s / 0.01s	Definite time	
OVGR [64G]	Time-delay(high)	OFF, 0.10~0.40Von / 0.02Von (Von=190V)	0.1~60.0s / 0.01s	Definite time	
	Time-delay(Low)	OFF, 0.10~0.40Von / 0.02Von (Von=190V)	0.1~60.0s / 0.01s	Definite time	
SGR [67G]	Zero-phase current(Io)	OFF, 0.6~3.6Ion / 0.2Ion (Ion=1.5mA)	0.1~60.0s / 0.01s	Definite time	
	Zero-phase voltage(Vo)	0.10~0.40Von / 0.02Von (Von=190V)			
	RCA	45° fixed			
POR [47]	Time-delay(high)	OFF, 5~100% / 1%	0.1~60.0s / 0.01s	Definite time	
	Time-delay(Low)	OFF, 5~100% / 1%	0.1~60.0s / 0.01s	Definite time	

Measurement functions

Parameters	Display	Accuracy	Remarks
Voltage, V	AC 0, 5~414,000V Bar graph 0~120%	±0.5%	Va, Vb, Vc Vab, Vbc, Vca
Current, A	AC 0.05~7,200A	±0.5%	Ia, Ib, Ic
Zero-phase voltage, Vo	0~190(V) Bar graph 0~120%	-	Vo, Vo_max(peak)
Active power, Watts	0~9,999MW Bar graph 0~120%	±1.0%	
Reactive power, Vars	0~9,999MVar	±1.0%	
Active energy, Wh	0~999,999MWh Bar graph 0~120%	±1.0%	
Reactive energy, Varh	0~999,999MVarh Bar graph 0~120%	±1.0%	
Power factor, PF	Lead/Lag 0~100%	±1.0%	
Frequency, F	45~65Hz	±0.5%	

Digital Integrated Protection & Monitoring Device

Communications

Modbus/RS-485

- Operation mode: Differential
- Distance: Max. 1.2km
- Cable :
General RS-485 shielded twist
2-pair cable
- Baud rate :
9600bps, 19200bps, 38400bps
- Transmission method: Half-Duplex
- Termination: 150 Ω

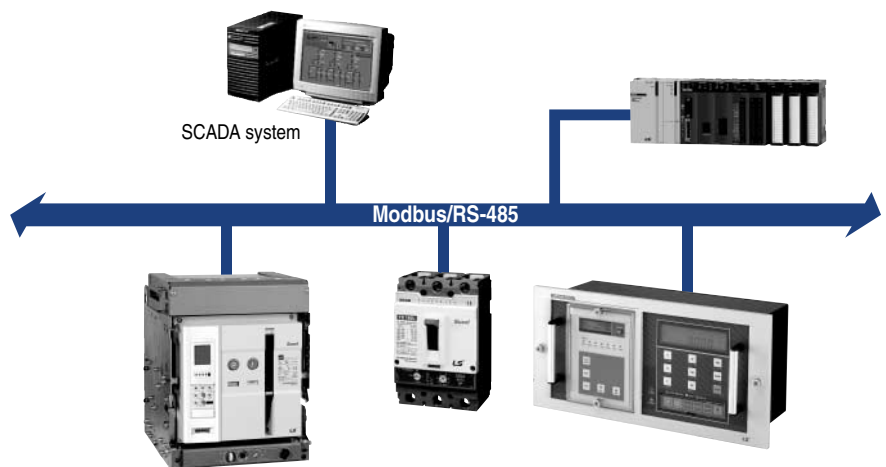

I-NET communication standards

I-NET is an express and high reliable communication which is designed with Custom LSI(GCV14605) ASIC Chip developed by LSIS.

- Communication Speed: 250kbps
- Communication Line:
Low capacitance LAN Interface cable
- Communication range: Maximum 1 km
- Specification:
LIREV-AMEBSB 22AWG 2-pair (7/0.254TA)
- Isolation Method: Pulse Transformer
- Characteristic Impedance: 10MHz, 120Ω
- Connection Method: 4-Wire Multi-drop
- Termination: 2 Vertical 120Ω resistances are needed in the both sides of the line ends.
- Signal Modulation: Bipolar

Extra Communication Equipments.

Protocol Converter (GMPC)

- Converting into RS-232/485/422 common use, Ethernet
- Supporting DNP3.0, MODBUS Protocol



External & MMI

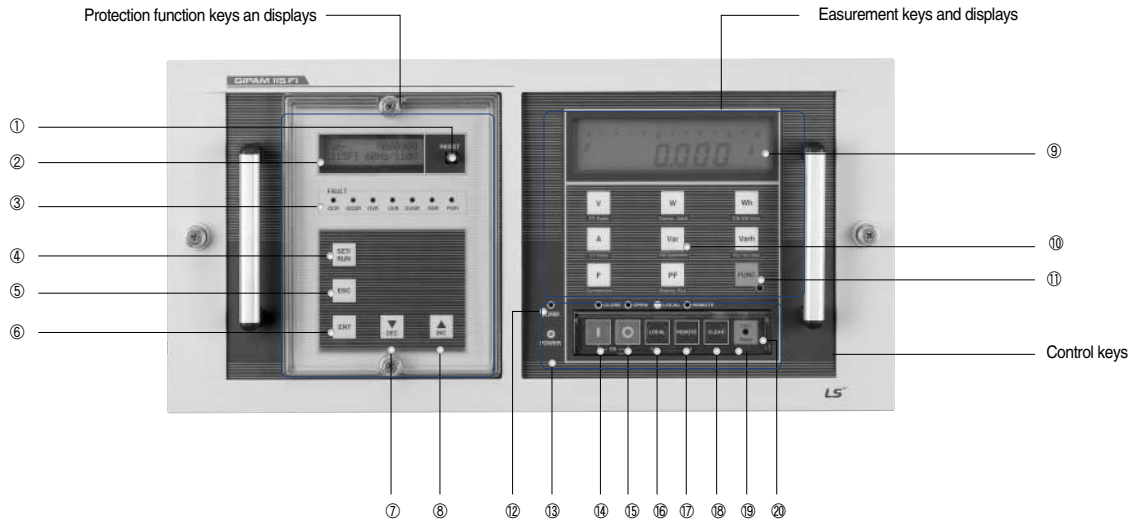

Key No.	Description	Key No.	Description
1	Reset key to reset fault indications	11	Function key, red LED
2	16×2 Text LCD	12	Communication LED, blinking on communicating
3	Fault indication LEDs	13	Power LED, red LED
4	Set/Run key	14	CB ON key, red LED
5	ESC key	15	CB OFF key, green LED
6	Enter key	16	Selection key for CB local operation, yellow LED
7	Decrement key	17	Selection key for CB remote operation, yellow LED
8	Increment key	18	Clear key
9	LCD display	19	CPU reset key
10	Display selection key	20	Control key protection cover

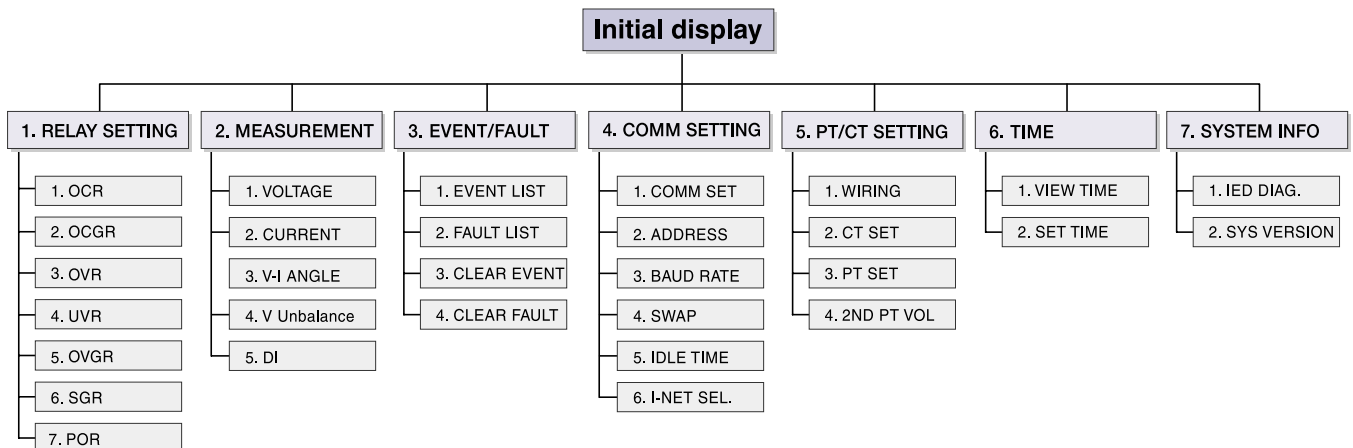

Digital Integrated Protection & Monitoring Device

Operation curves

Operation time, t(sec) = T x tap, tap = 0.05 to 1.00

Type of curve	T	Type of curve	T
SI, Standard Inverse	$T = \frac{0.14}{(I/I_s)^{0.02} - 1}$	D2, Definite Time	T = 2
VI, Very Inverse	$T = \frac{13.5}{(I/I_s) - 1}$	D4, Definite Time	T = 4
EI, Extremely Inverse	$T = \frac{80}{(I/I_s)^2 - 1}$	D8, Definite Time	T = 8
LI, Long Inverse	$T = \frac{120}{(I/I_s) - 1}$		

Note) I = operation current, I_s = set current
In case of OVGR substitute (V/V_s) for (I/I_s).

POR(Phase open relay)

Voltage unbalance $V_{unbal} = \frac{V_{max} - V_{min}}{V_{avg}} \times 100\%$ (setting range 5~100% / 1%)

$$V_{max} = \max(|V_a|, |V_b|, |V_c|)$$

$$V_{min} = \min(|V_a|, |V_b|, |V_c|)$$

$$V_{avg} = \max(|V_a| + |V_b| + |V_c|) \times \frac{1}{3}$$

SI curves for OCR, OCGR

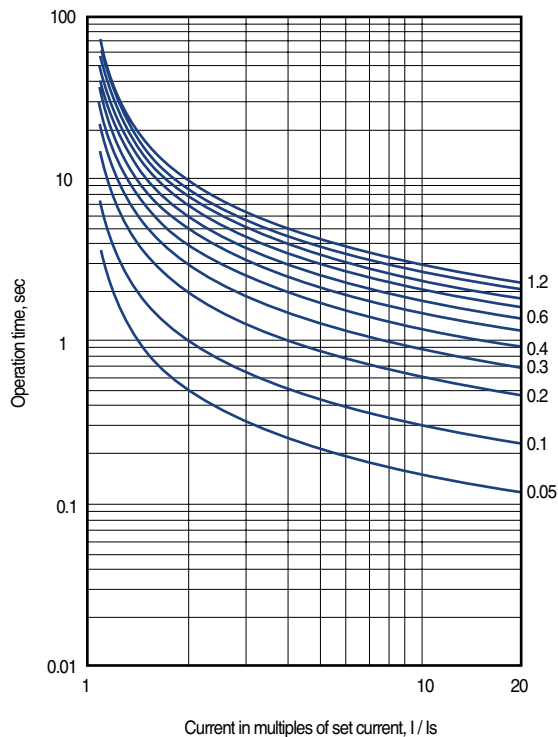

VI curves for OCR and OCGR

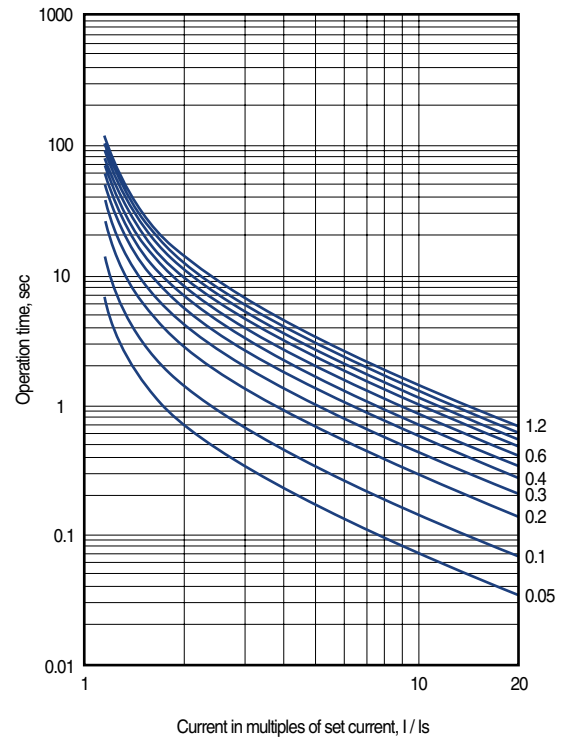

EI curves for OCR and OCGR

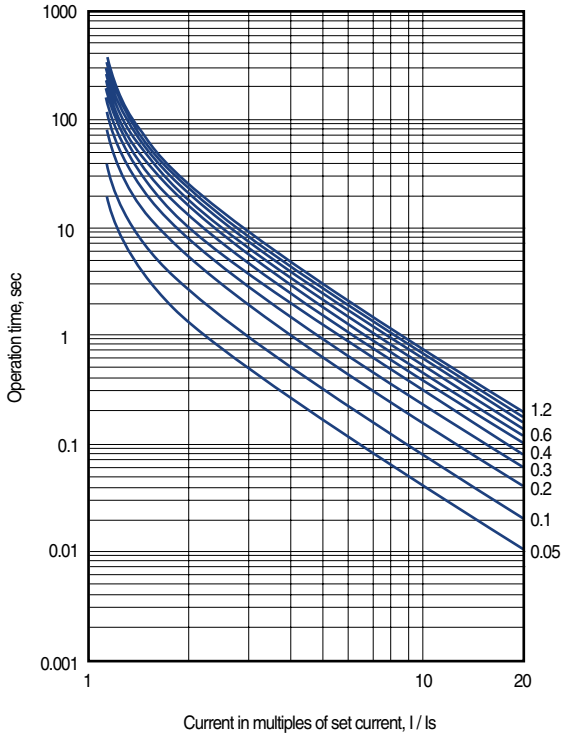

LI curves for OCR and OCGR

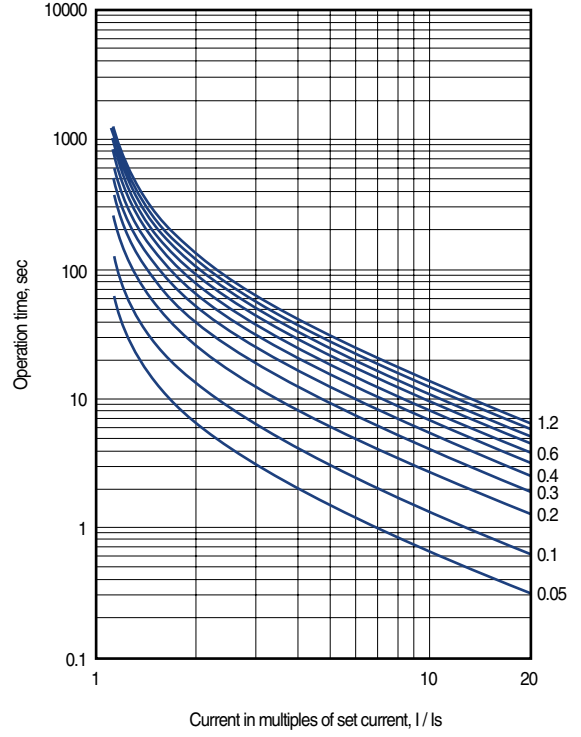

Definite Time curves for UVR and OVR

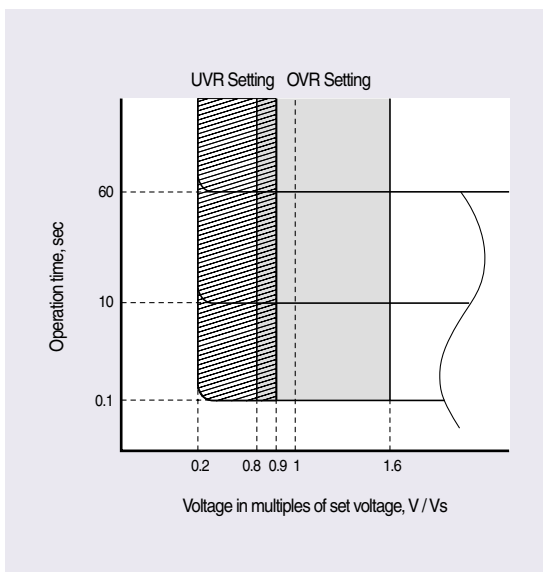

Operation phase characteristic of SGR

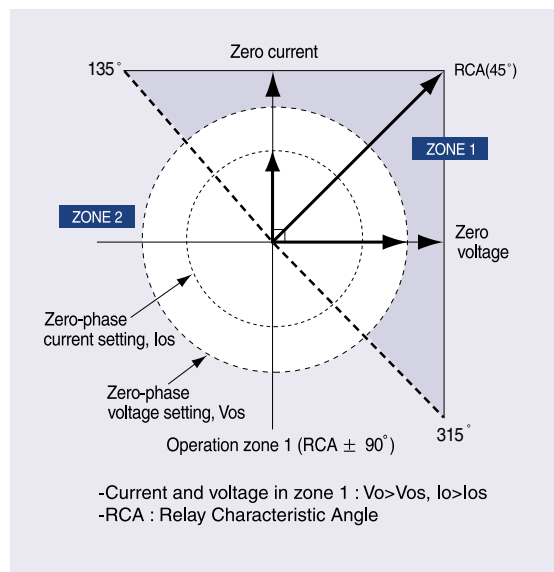

Digital Integrated Protection & Monitoring Device

Wirings

[Output terminal block]			
A01	OCR	ALARM+	A02
A03	OCGR/SGR	ALARM-	A04
A05	OVR	Aux DI+	A06
A07	UVR	Aux DI-	A08
A09	OVGR	REMOTE	A10
A11	POR	LOCAL	A12
A13	F.G	L/R COM	A14
A15	ALARM COM	RX0	A16
A17	CB ON+	RX1	A18
A19	CB ON-	TX0	A20
A21	CB OFF+	TX1	A22
A23	CB OFF-	COMM GND	A24

[Input terminal block]			
B01	IR+	IR-	B02
B03	IS+	IS-	B04
B05	IT+	IT-	B06
B07	In+	In-	B08
B09	VR+	VR-	B10
B11	VS+	VS-	B12
B13	VT+	VT-	B14
B15	Io+	Io-	B16
B17	CB ON+	CB OFF+	B18
B19	CB ON-	CB OFF-	B20
B21	Vo(+)	DC(+)	B22
B23	Vo(-)	DC(-)	B24

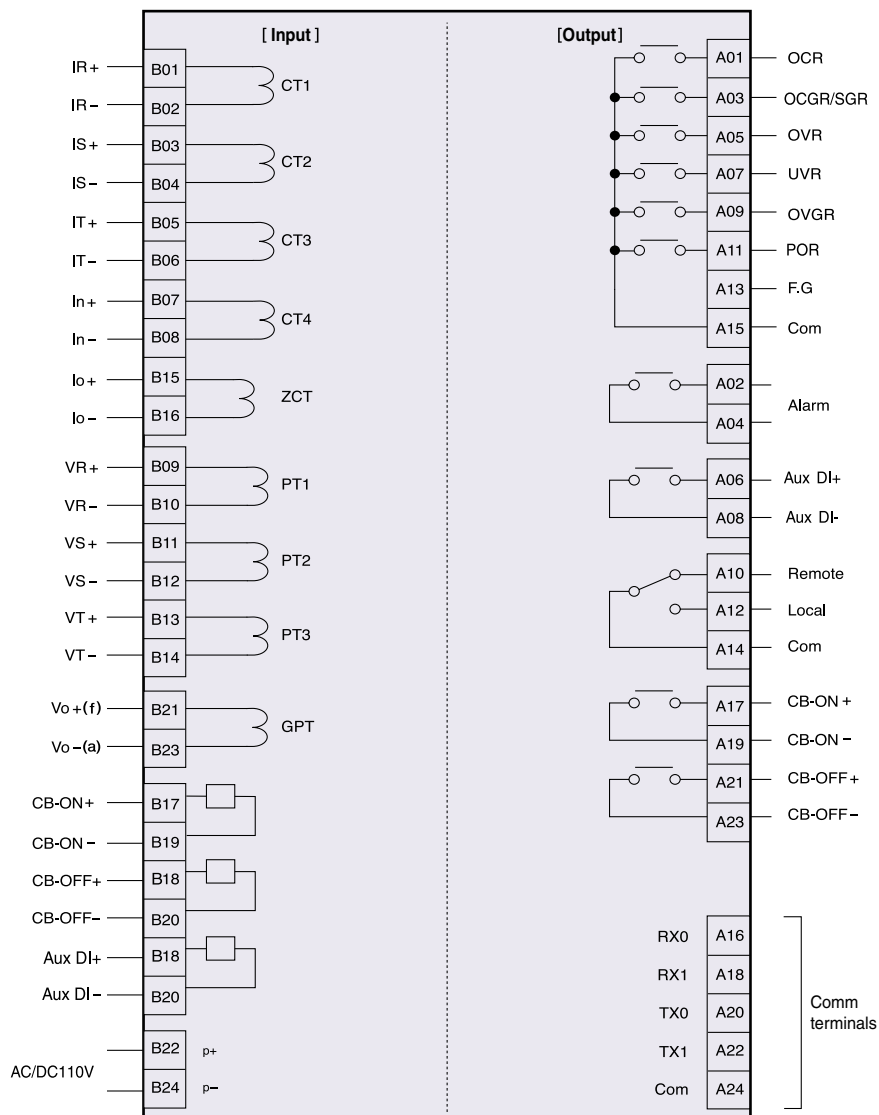

Note) 1. Avoid connecting GIPAM parallel with the other devices that generate noises.
2. Press the clear switch to initialize all data after installation.

1P 2W

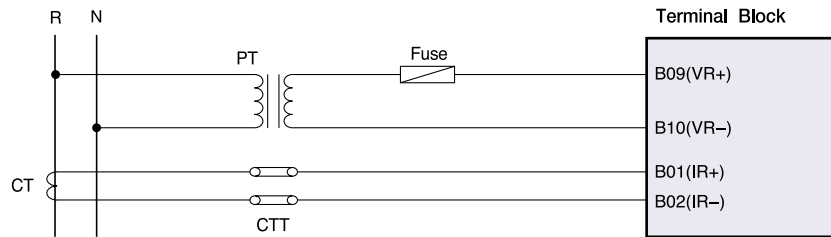

1P 3W

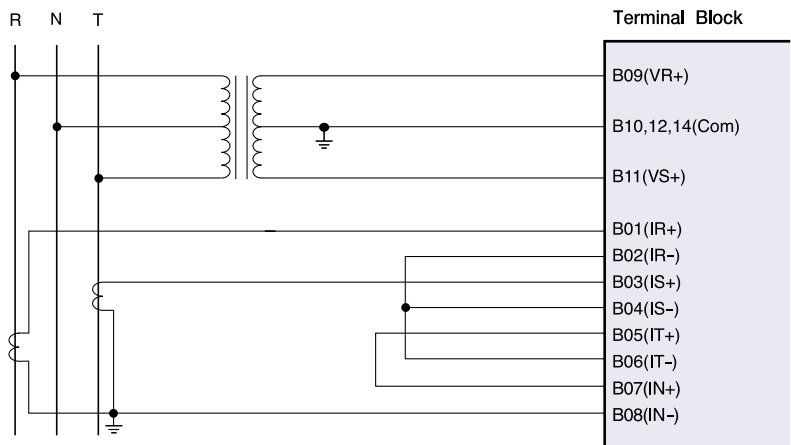

3P 3W(with 2CT, 2PT)

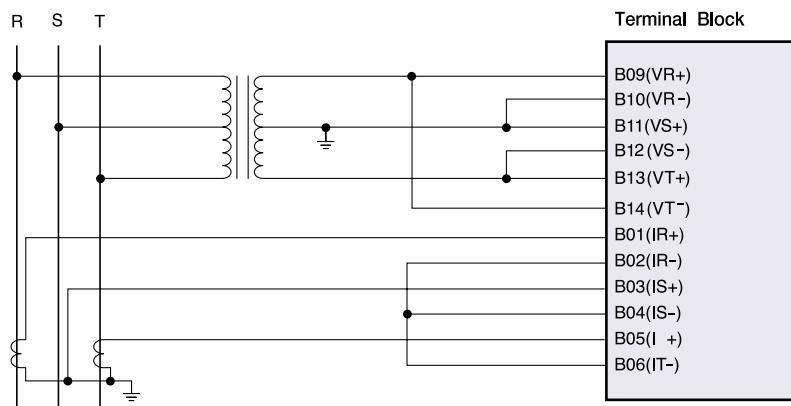

3P 3W(with 3CT, 2PT)

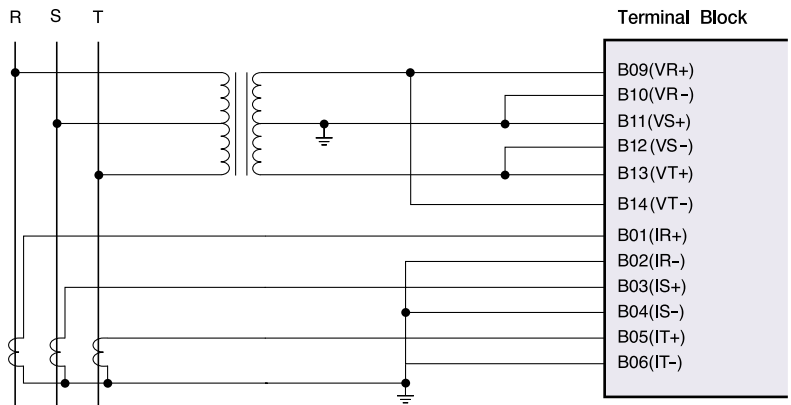

Digital Integrated Protection & Monitoring Device

Wirings

3P 3W

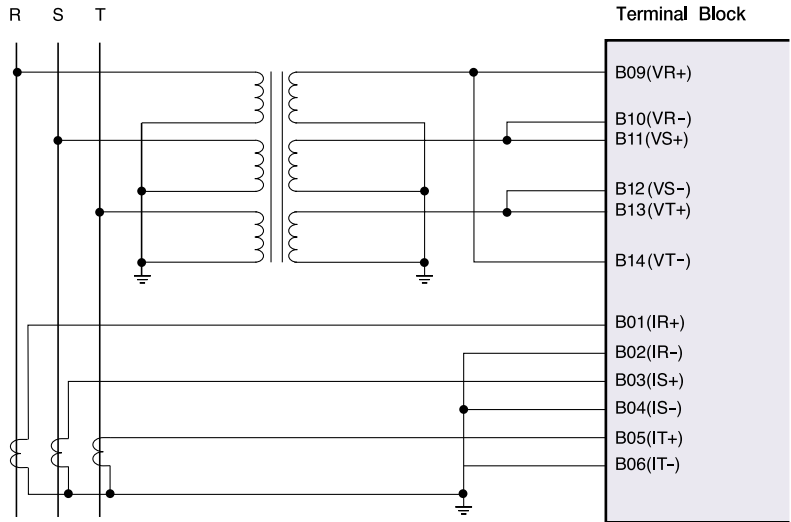

3P 4W (NCT is available)

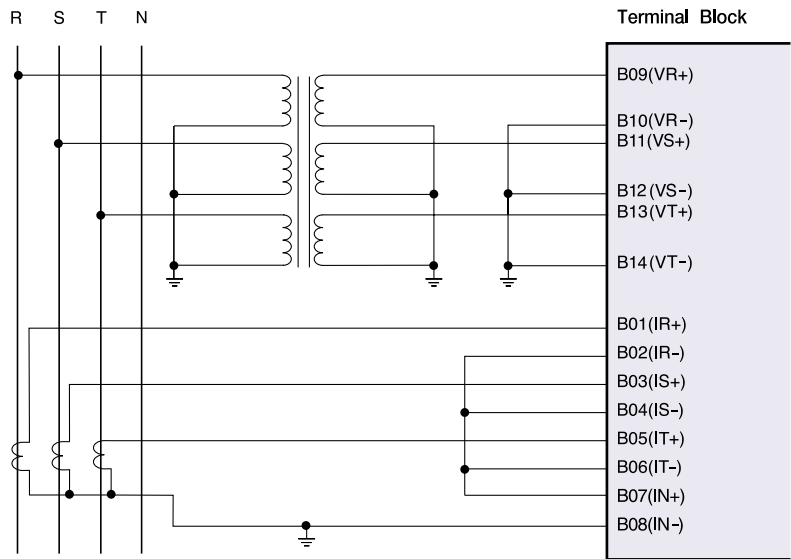

ZCT

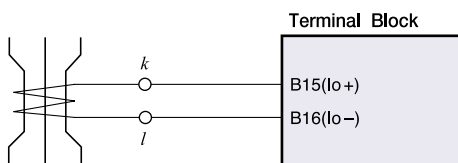

GPT

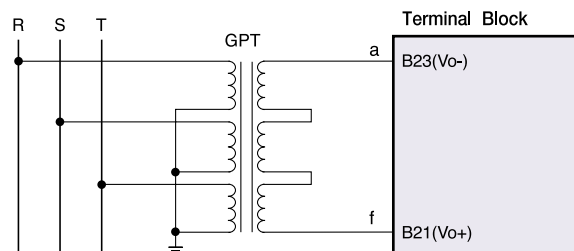

Dimension & Ordering

Dimensions

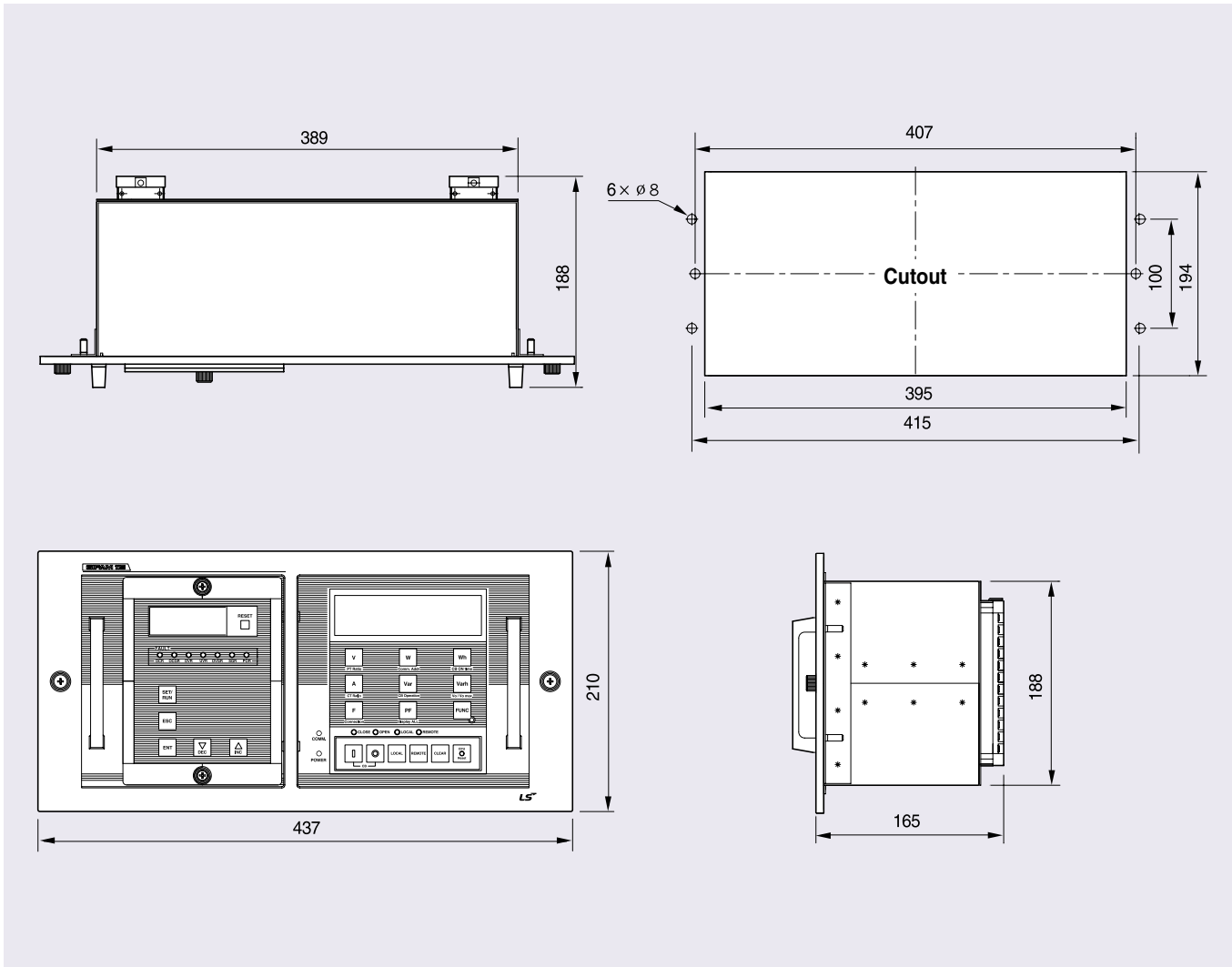

Ordering

GIPAM-115

FI	RS	M	60Hz
Protection	Communication	Protocol	Frequency
FI Feeder, Incoming	RS RS-485	M MODBUS	60Hz
	IN I-NET	I I-NET	50Hz

DPR-1000



Digital Protection Relay

DPR-1000 is the digital protective relay which is intended for monitoring and protecting the faults on the feeder of distribution system, especially for the medium-voltage motors.

- 11 protective function for the medium-voltage motors
- Compact type protective relay with built-in various add functions
- Remote control & Monitoring of circuit breaker
- MODBUS, DNP3.0 / RS-485 communication



IEC 60255, KEMC 1120
ISO 9001, ISO 14001





N₄



Contents :

Feeder/Motor protection relay	N-4-4
Rating	N-4-5
Technical Specifications	N-4-6
Dimension	N-4-7
Ordering	N-4-8



Digital Protective Relays

Feeder/Motor protection relay

DPR-1000 is the digital protective relay which is intended for monitoring and protecting the faults on the feeder of distribution system, especially for the medium-voltage motors.

- 11 protective function for the medium-voltage motors
- Compact type protective relay with built-in various add functions
- Remote control & Monitoring of circuit breaker
- MODBUS, DNP3.0 / RS-485 communication

Function

Protection & Control

- Overcurrent (50/51P), Overcurrent ground (50/51N)
- Thermal (49), Negative sequence overcurrent (46)
- Selective ground (67G), Directional ground (67N)
- Under current (37), Stall & locked rotor (48/51LR)
- Starts per hour (66)
- Lock-out (86)
- 2 analog inputs (Thermistor)
- 5 digital outputs
- 3 digital inputs

Monitoring & Metering

- I, Io, I2, Vo
- Temperature (2 ch.)
- Starting current, starting time, full load current, thermal, etc.
- Event triggered wave recording: 15 Traces (Ir, Is, It, Io, Vo, AI1, AI2, DI/DO, etc.)

User Interface

- 20 × 4 Character LCD
- DNP3.0, Modbus/RS-485
- PC interface software (GIPAM manager : DPR-OPTO MASTER)

Block diagram

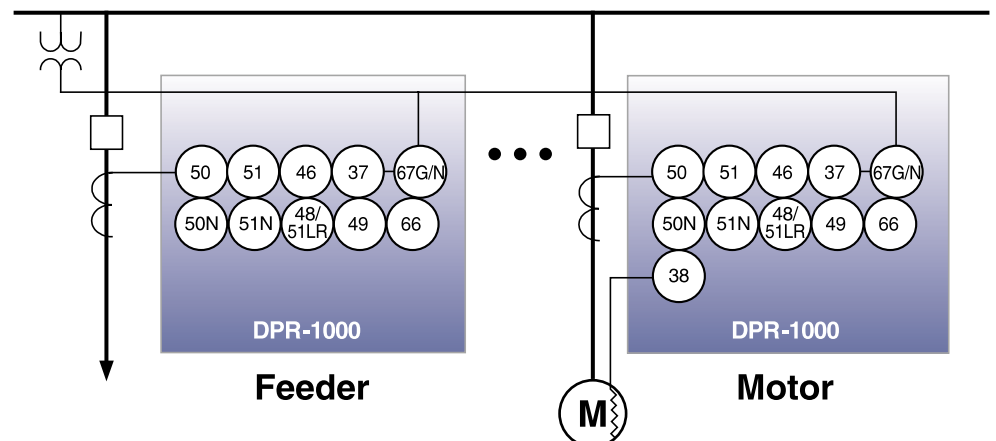

Technical Specifications

Rating

Type		Specification	
Wiring		3P3W, 3P4W	
Input	Frequency	60Hz or 50Hz	
	Voltage	GPT 190, 190 / $\sqrt{3}$	
	Current	CT	5A
		ZCT	1.5mA
	Control voltage	AC/DC: 110V	
	Power consumption	Steady: below 30W Operating: below 70W	
	Burden	PT	0.5VA
		CT	1.0VA
Digital Input	Digital Input: AC/DC 110V		
Output	For trip	AC 250V 16A/DC 30V 16A Resistive Load AC 2500VA, DC 300W	
	For alarm	AC 250V 5A/DC 30V 5A Resistive Load AC 750VA, DC 90W	
Insulation resistance		Over DC 500V 100M Ω	
Insulation voltage		AC 2kV (1kV)/for 1 min	
Impulse voltage		AC 5kV (3kV) Over 1.2 \times 50 μ s	
Overload Withstand	Current circuit	2 · In for 3 hours 20 · In for 2 seconds	
	Voltage circuit	1.15Vn for 3 hours	
Fast transient disturbance		Power Input 4kV Other Input 2kV (Analog Input 1kV)	
ESD (Electrostatic Discharge)		Air 8kV Contact 6kV	
Operation temperature		-10°C ~ 55°C	
Storage temperature		-25°C ~ 70°C	
Humidity		Average 30% ~ 80%	
Altitude		1000m and below	
Others		Non-impact place Non-air pollution palce	
Standard		IEC 60255, IEC 61000-4, KEMC 1120	
Dimension (W \times H \times D)		120 \times 245 \times 185 (mm)	
Weight		3.4kg	

Digital Protective Relays

Technical Specifications

Protection functions

Protective function	Operating part	Setting & Operating time	Remark
OCR (50/51)	Instantaneous high set	Setting: OFF, 0.5~20.0/0.1In	Below 40ms
	Instantaneous low set	Setting: OFF, 0.5~20.0/0.1In Operating time: 0.05~60.0/0.01s	Definite
	Time delay	Setting: OFF, 0.1~4.0/0.02In Operating time: 0.05~1.20/0.01 (Inverse)	Curves SI, VI, EI, LI
OCGR (50/51N)	Instantaneous	Setting: OFF, 0.1~8.0/0.02In Operating time: 0.05~300.0/0.01s	Definite
	Time delay	Setting: OFF, 0.02~2.0/0.01In Operating time: 0.05~1.20/0.01 (Inverse) 0.05~60.0/0.01s (Definite)	Curves DT, SI, VI, EI, LI
NSOCR (46)	Time delay high set	Setting: OFF, 0.1~1.0/0.02In Operating time: 0.08~60.0/0.01s	Definite
	Time delay low set	Setting: OFF, 0.1~1.0/0.01In Operating time: 0.05~1.00/0.01(Inverse) 0.08~60.0/0.01s(Definite)	Curves DT, SI, VI, EI, LI
DGR (67N)	Time delay	Io Setting: 0.02~2.0/0.01In Vo Setting: 11~80/1V RCA Setting: 0~90/1° Operating time: 0.05~10.00/0.01s	Grounded system Definite
SGR (67G)	Time delay	Io Setting: 0.9~6.0/0.01mA Vo Setting: 11~80/1V RCA Setting: 0~90/1° Operating time: 0.05~10.00/0.01s	Isolated system Definite
THERMAL (49)	Time delay	Setting: OFF, 50~100/1% (rh, τc)	Motor Config.
STALL/ LOCK (48/51LR)	Time delay (Stall)	Setting: 0.50~10.00/0.01 (FLC × SVC. × O/L)	Motor Config.
	Time delay (Lock)	Operating time: 0.05~300.0/0.01s(Definite) 0.05~1.20/0.01(Inverse)	Motor Config.
UCR (37)	Time delay	Setting: 0.1~0.9/0.02In Operating time: 0.05~300.0/0.01s	Definite
NCH (66)	-	Starts number: OFF, 1~5 times/1 Base time: 10~60min/1min Time between starts block: 1~60min/1min Operating time: 10~80%/1%	Notching
TPR (38)	Time delay	Setting: OFF, 20~180/1°C Operating time: below 50ms	Definite

Motor protection

Motor factor	Setting & Operating time	Remark
STALL/ START TIME	Tss (Stall operating time): 0.05~300.00/0.01s Ts (Motor starting time): 1.0~300.0/0.1s	-
FLC/LRC	FLC: 0.20~2.00/0.01In LRC: 0.50~10.00/0.01FLC	FLC: STALL Setting LRC: LOCK Setting
SERVICE FACTOR	SVC: 1.00~1.20/0.05	-
THR CONST	Thermal const.(Heat): 2.0~60.0/0.5min Thermal const.(Cool): 2.0~60.0/0.5min Overload Const. (O/L): 0.80~1.20/0.05	THR (49) Setting
OCGR BLOCK TIME	B/T : 0.00~60.00/0.01s	Operating delay time

Measurement

Item	Display range	Remark
Line / Load current	0, 0.05A ~ 200A (CT ^{prf})	Start current (CT ^{sec}) : 0.050A
Starting current (Is_avg, Is_peak)	0, 0.05A ~ 200A (CT ^{prf})	Start current (CT ^{sec}) : 0.050A
Starting time (Ts_avg, Ts_peak)	0.000sec ~ 4294967.296sec	-
%FLC, %FLCavg, %FLCpeak	0.000% ~ 999.99%	Start %FLC: 5.000%
Io, Io max	0, 0.05A ~ 40A (NCT ^{prf}) 0, 0.15A ~ 30A (ZCT ^{prf})	Start current (CT ^{sec} /ZCT ^{sec}) : 0.050A/0.15mA
Vo, Vo max	0, 2.2V ~ 200V (PT ^{prf})	Start voltage (PT ^{prf}): 2.2V
I₂	0, 0.05A ~ 200A (CT ^{prf})	Start current (CT ^{sec}): 0.050A
%Q, %Qavg, %Qpeak	0.000% ~ 150.0%	Start capacity: 5.000%
Analog Input (AI) 1, 2	4 ~ 20mA DC	Option

Digital Protective Relays

Dimension

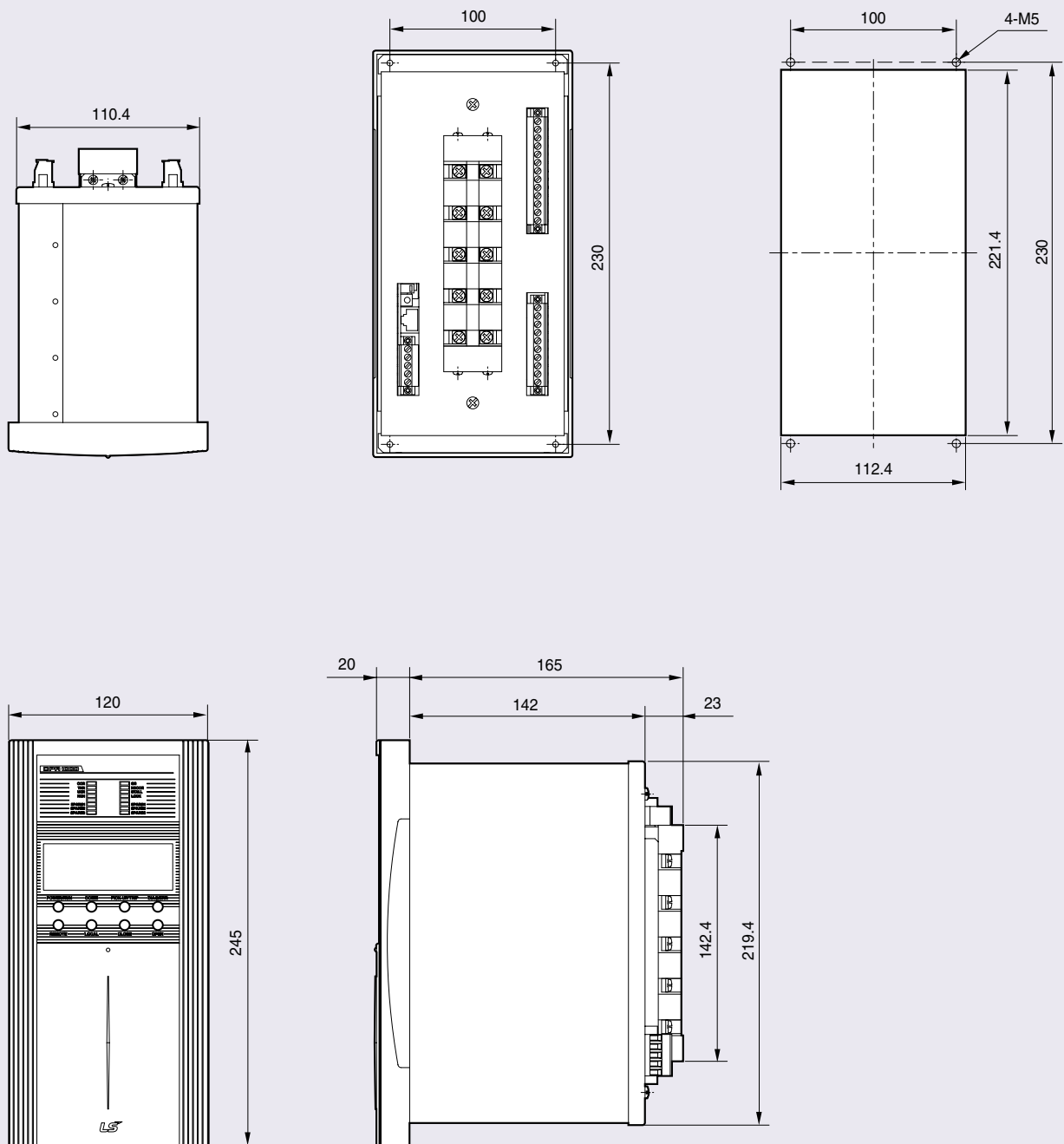

Ordering

DPR-1000

FN		RS		D		AI		60Hz	
Protection usage		Communication		Protocol		Analog Input		Frequency	
FN	Feeder, Motor/NCT	RS	RS-485	M	MODBUS	AI	4-20mA		60Hz
FZ	Feeder, Motor/ZCT	-	Without comm.			-	Without AI		50Hz

DPR-OPTO MASTER —

IrDA Serial Port(Optional)
PC Interface Software

Digital Protection Relay DPR-1000



IMC-IIIa



Intelligent Motor Controller



IEC 60255, IEC 61000-4, IEC 60068-2, EM 50081-2
ISO 9001, ISO 14001



IMC-IIIa also has various motor protection function, and is possible to communicate with PLC, Water level for auto operating, remote control and monitoring by RS-485, 4~20mA(only monitoring).

N₅



Contents :

Main characteristic	N-5-6
Ratings and function	N-5-8
Main function description	N-5-10
Operation and setting	N-5-11
Wiring method	N-5-15
System configuration	N-5-18
Accessories	N-5-20
Dimension & Ordering	N-5-21



IMC-IIIa

Digital motor protection control unit

Various motor start application within one model.

IMC-IIIa includes Direct, Y- Δ , Forward/Reverse, Reactor, Inverter, S/V valve start, solution for complicated water treatment Sequence.

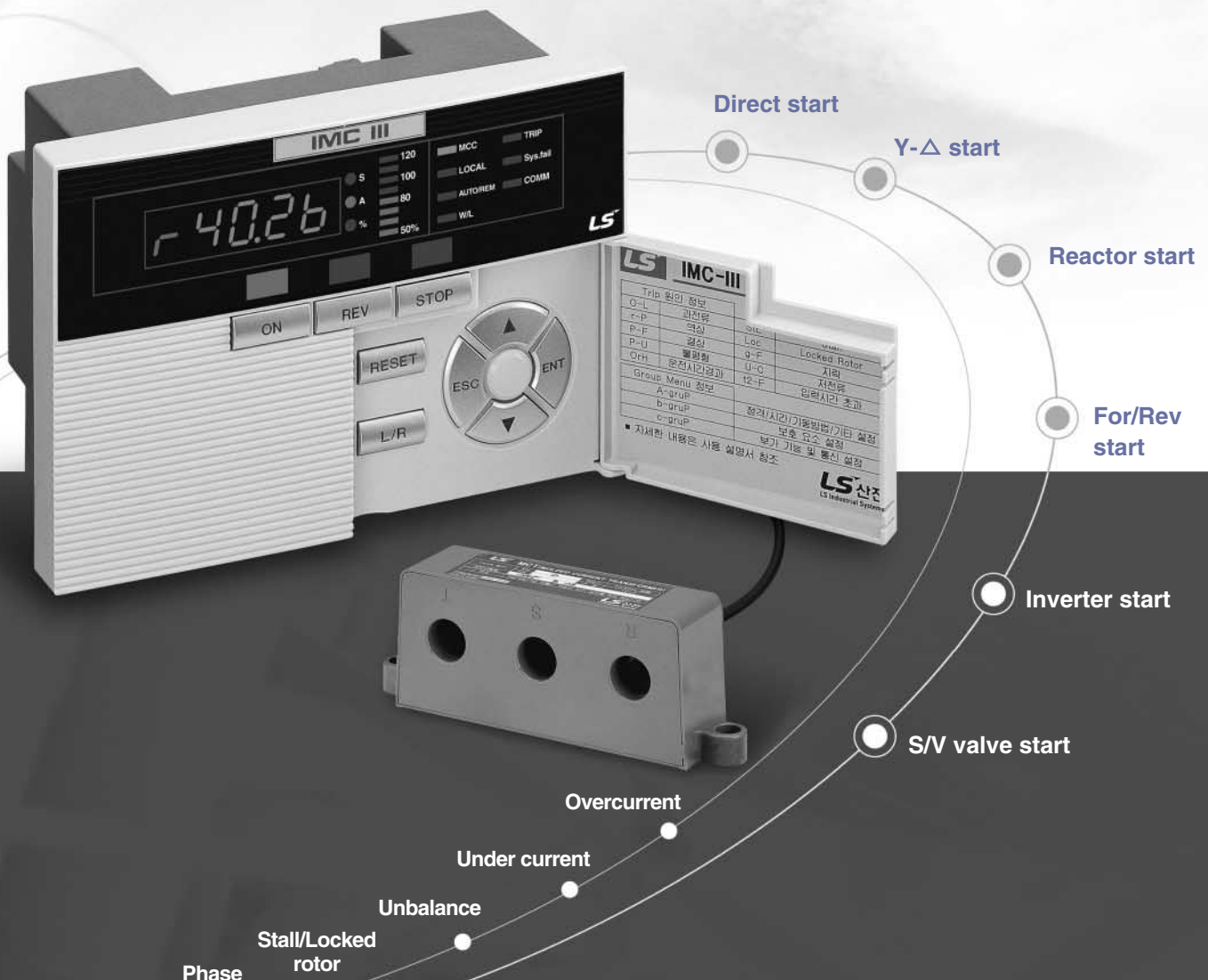

- Direct start
- Y- Δ start
- Reactor start
- For/Rev start
- Inverter start
- S/V valve start

- Overcurrent
- Under current
- Unbalance
- Stall/Locked rotor
- Phase loss
- Phase reverse
- Earth fault

Various protection function

Safely protection for over current, Under current, Phase loss, Unbalance, (Stall, Lock) Earth fault, Alarm function.

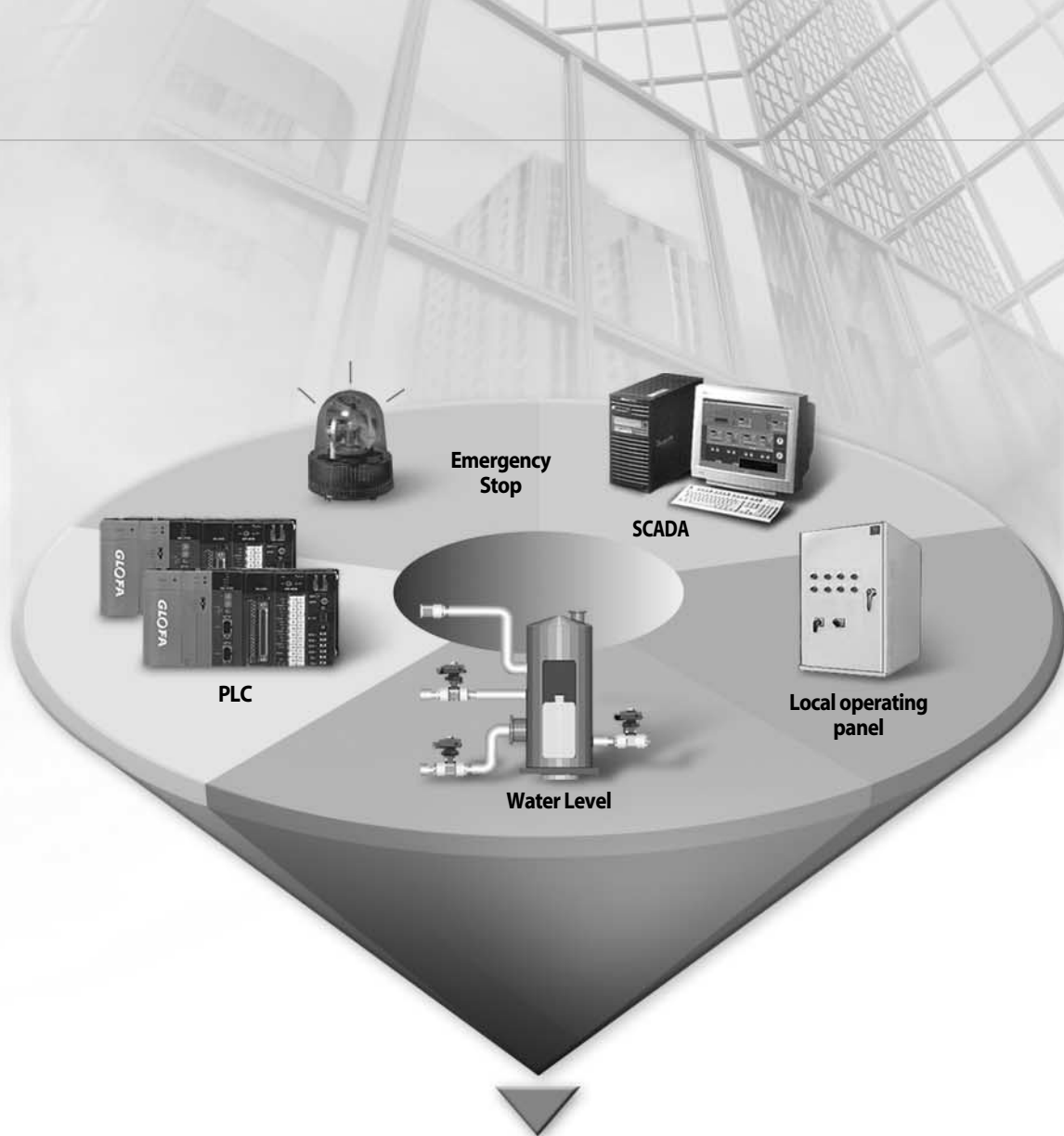

Various remote control and monitoring

It is possible to operate at MCC and LOP by just simple sequence, also can be automatic operation up to water level by remote control and monitoring with PLC/DCS.

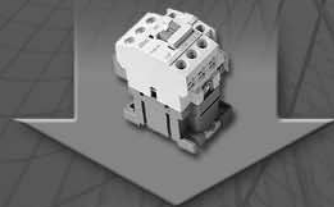

Intelligent Motor Controller

Main characteristic

Easy and convenience installation

It can be checked fault analysis and operated motor by inserting the main unit into panel. It's possible to set current/operating time/various function easily by simple button. And it can be also composed of compact MCC, minimized wiring work, so user can reduce labor cost.

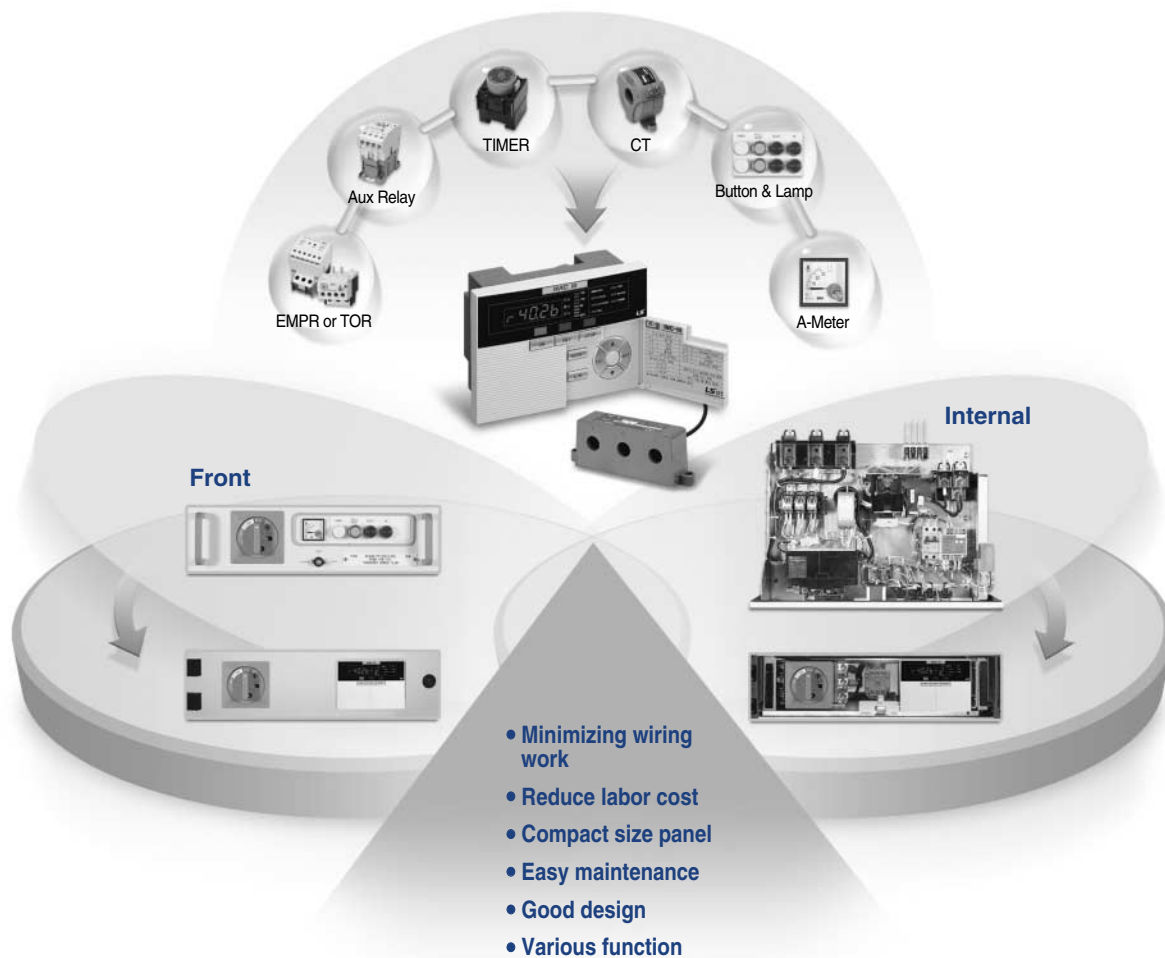

Wide current setting range : 0.125A~1000A within 1 model

It can be changed from 0.5~6A to 5~60A by slide S/W, the current can be changed to 0.125A up to MCT number of the time of penetrating current line.

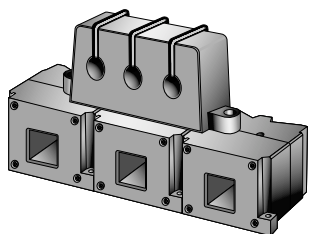

• External CT

* External CT : Note p22 (option)

* MCT : Molded current transformer(Enclosing with product)

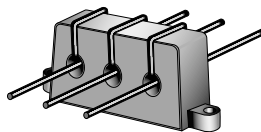

• 2 times(0.25~3A)

• A group → 5.ctr 0.5 setting

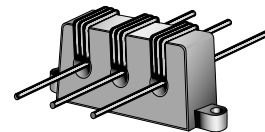

• 4 times(0.125~1.5A)

• A group → 5.ctr 0.25 setting

The moment stopping of power supply compensation and Restart

■ The moment stopping of power supply compensation

- Line current reduces under 65% of rated voltage.
- When the moment stopping of power supply within 10S, IMC-IIIa makes it restart same as before condition.

■ Restart delayed time(0~300S)

- When the line voltage recovers over 75% rated voltage, it can be restarted.
- when it restarted, IMC-IIIa makes it sequence restart 0~300s for prohibition overload.
- Indication of Restart delayed time countdown.

■ Operating condition and maintain operation mode

- It can be maintained before the moment stopping power supply condition(Local, MCC, Auto, Remote)

Ex) Incase of restarting delayed time 30S



Information

- It can be changed operation mode (ON, OFF) and count time during countdown
- Changed operation mode can be applied after finishing count.
- When the short stopping power supply generates under 100ms, IMC-IIIa dose not detect, so the motor will maintain normal condition

Digital ampere-meter

It can be monitored indication of R, S, T current, and load ratings(%) by Bar LED.

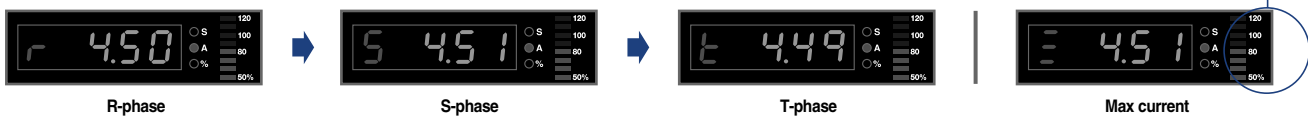

Fault analysis and Recording

It can be indicated fault cause and fault current value by 7-segment and LED.

At the moment of instantaneous stopping of power supply, it can solve the problem. Because of the fault storage.



Self-supervision and contactor failure function

IMC-IIIa can be checked self-supervision like a memory fault. When the motor starts/stops, that indicates Error.No and turn on Sys.Fail LED by supervising Input/output condition.

Total operation time setting and storage

It can be stored motor operation time up to 10 years. Continuous operation time can be stored and setting.

Information

When the user contact mode is normal mode, even if indicating "OrH Alarm, motor operates in normal condition

Communication function

It's possible to communicate with other system and organize various communication Network by MODBUS/RS-485. And it's also possible to communicate with system by Analog current signal(4~20mA). So that makes it possible to interchange by using TD(Transducer).

4~20mA output

0.5~6A Mode		External current transformer (Secondary Current)		5~60A Mode	
Under 0.35A	Over 6A	Under 0.35A	Over 5A	Under 3.5A	Over 60A
4mA	20mA	4mA	20mA	4mA	20mA

Intelligent Motor Controller

Ratings and function

Rating

Model	IMC-IIIa			
Operating time	Characteristic	Inv/Def time		
Current range(A)	0.125~60A(Within 1 model)			
Time setting (s)	Inverse time	1~60sec/1sec(Class)		
	Definite time	D-Time *	1~200sec/1sec	
		O-Time *	1~60sec/1sec	
	Auto re-closing time	1~20min/1min, OFF		
Control power	Voltage	AC 110V or AC 220V(±15%)		
	Frequency	50/60Hz		
	Power consumption	Under 6W		
Output contact (7EA)	Capacity	5A/250VAC impedance load		
	Composition	Operating contact	3a	
		Condition contact	3a	
		Trip contact	1a	
Forward/Reverse, Y-Δ, Reactor, Inverter start				
Input contact (8EA)	Operating input	5a	Local, Auto, ETC	
	MC condition input	1a	MC condition monitoring	
	External trip	1a	Emergency stop	
	ZCT	Ratings	200mA/0.1mA(ZCT)	
		Specification	ø 25, ø 40, ø 80	
Indication	7-Segment	3-Phase current, Trip cause, Settings		
	LED	Operating, Trip, System fail, Communication status		
Self-Diagnostic	System fail LED and err indication			
Communication(Optional)	Modbus/RS-485 or 4~20mA			
Installation	Inside the panel			
Separate cable	MCT cable 2m base(4m cable option)			
Insulation voltage	AC 2kV(1.5kV) / 1 min			
Impulse voltage	Over AC 5kV(3kV), 1.2x50μs			
Insulation resistance	Over DC500V 10M Ω			
Power frequency magnetic field	100A/m, 50Hz			
Burst disturbance	Common 2.5kV			
	Differential 1.0kV			
Fast transients disturbance	Input 2kV, Other Input 1kV			
Electrostatic Discharge	Air 8kV, Contact 6kV			
RFI	30cm near electric wave by 5W transceiver(230MHz)			
EMI	AC power : 0.15~0.50MHz, Standard : 79dB, Average : 66dB 0.50~30MHz, Standard : 73dB Average : 60dB			
Operating temperature	-10 ~ 55°C			
Storage temperature	-20 ~ 70°C			
Relative humidity	80% @40°C for 56days			
Standard	IEC 60255, IEC 61000-4, IEC 60068-2, EN 50081-2			
Weight	0.6kg(MCT 0.35kg)			
Dimension	Main unit	148(W) × 100(H) × 74(D) mm		
	MCT	151(W) × 55(H) × 33(D) mm		

* D-Time(Delay time) : It is delay time for IMC-IIIa start during motor start time

* O-time (Operating delay time) : When over current generates more then setting current, that makes it delayed until IMC-IIIa operated.

Motor protection

		Operating condition	Time	Remark
Over current	Inverse	Over 110% setting current	1~60s/1s	600% standard operating time
	Definite time	Over 105% setting current	1~60s/1s	Delay time 1~200s
Phase fault		Over 70% current phase unbalance	Within 1.5s	Phase fault rate = $\frac{\text{Maximum Phase Current} - \text{Minimum Phase Current}}{\text{Maximum Phase Current}} \times 100\%$
Phase unbalance		Current phase unbalance 30~50%	Within 5s	
Reverse phase		Reverse the current phase	Within 0.1s	Over 110% minimum ratings
Under current		Rating current 30~70%	Within 3s	
Holding	Stall	Rating current 150~300%	Within 5s	Detection after over current setting time
	Locked rotor	Rating current 200~700%	Within 0.5s	
Ground fault		The current rating 0.1~2.5A setting	0.05~1.0s	Ground fault delay operation
Pre-alarm		Over 120% setting value		Bar-LED blinking

Sequence function

		Contents	Remark
Operating type	Direct operation	Non-reversible direct operation	
	Y-Δ operation	Y operation time	1~120s/1s
		Y-Δ switching time	0.05, 0.1, 0.2s
	Forward / Reverse operating	Reversible direct operation	
	Reactor	Reactor time	1~120s/1s
Inverter	Inverter delayed time	ON 1sec/0.1sec	
Instantaneous under voltage compensation	Compensation time	OFF 1~10s /1s	
	Re-operation delay time	0~300s /1s	
	Under voltage detection	(Rating control voltage × 65%) ± 10%	
	Recovering voltage detection	(Rating control voltage × 75%) ± 10%	
Remote control	Local	LOP(Local Operation Panel)	
	MCC	Motor Control Center	
	Auto	PLC, DDC, DCS auto operation	
	Remote	Modbus/RS-485 communication	

Communication function

Type	Contents	Specification	Remark
Modbus / RS-485	Protocol	Modbus_RTU	
	Communication	RS-485	
	Operation	Differential	
	Baud rate	9600, 19200, 38400bps	
	Length	Max 1.2km	Different from local situation
	Cable	RS-485 Shielded twist 2-pair cable	
	Transmission	Half-duplex	
	Max in/Output voltage	-7V ~ +12V	

Intelligent Motor Controller

Main function description

Protection function

Overload protection(49)

Overload protection function senses current which is flowing on the motor, and tracing the heat, and then protects. When the heat capacity approaches, it generates overload trip, and this heat capacity is calculated by characteristic curve and I^2t . Class1 ~Class60 overload characteristic curve is determined by setting motor's rated current, considering motor operating time, setting operating time 1s~60s by according to 600% of setting current. When you choose the definite time characteristic, it starts over current after Delayed time and if over current keeps applying over Operation-time, it generates trip.

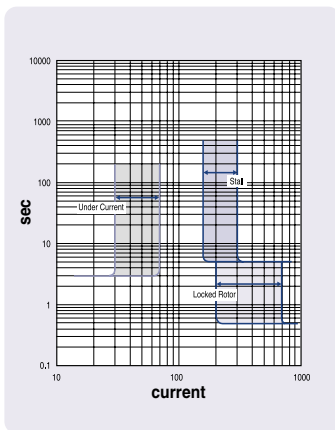
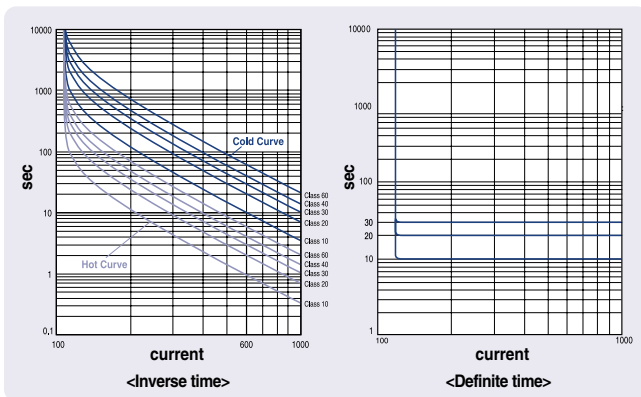

Stall/Locked rotor protection (48/51LR)

When the fault generates like locked rotor, the mechanical units like pump, fan can be damaged easily. IMC-IIIa prohibits stall, locked rotor, start failure, over current and open the circuit when the current increases rapidly, load torque exceeds the motor torque. But IMC-IIIa has delayed time, it can not be tripped by operating current.

Under current protection(37)

Protection of no-load condition by operating axis separation, maintenance of pump no-load and in case of motor frigidus method, it can be used for protection of operating terminal overload. It's possible to set 30~70% of rated current, it operates within 3s.

Phase fail/Phase unbalance protection-47P

If the phase fail generates due to the motor internal fault or wiring problem. Motor cannot operate or keep operating, In this case, high reverse phase current applied, so motor can be damaged. IMC-IIIa will trip within 1.5s when the unbalance rate is over 70%. IMC-IIIa will trip within 5s, when the unbalance rate is over 30~50%. However, when you applied 1p motor, it can not be detected phase-fail and unbalance. User has to be off in this case.

Reverse phase protection

Reverse phase protection prohibits motor reverse rotation when the phase of current changed each other. IMC-IIIa will trip within 0.1s, when the phase changed each other by comparing 3phase difference. IMC-IIIa can detect the reverse phase over minimum 110%, of setting current, during motor operation. When the 1p motor is applied, it can not be detected reverse phase. User has to be off in this case.

Ground fault protection-51G

This function protects fault circuit by detecting earth fault, ground fault. And this function also protects second fault (short circuit, electric shock) by detecting earth fault current. User has to set the current value, operating time differently by protection system. Ground fault sensing current can be set 100~2500mA, and ground fault operating time can be set 0.05s~1s. The separate ZCT (Zero phase current transformer) is used for detecting ground fault current. However, when the IMC-IIIa start inverter operation, it can not be protected ground fault Protection. User has to be OFF.

Fault analysis, fault recording

User can check fault current value by UP/DOWN button and fault recording can be checked by [ESC + ENT].

	<input type="radio"/> S <input type="radio"/> A <input type="radio"/> %		<input type="radio"/> S <input type="radio"/> A <input type="radio"/> %
Overload		Under current	
	<input type="radio"/> S <input type="radio"/> A <input type="radio"/> %		<input type="radio"/> S <input type="radio"/> A <input type="radio"/> %
Locked rotor		Stall	
	<input type="radio"/> S <input type="radio"/> A <input type="radio"/> %		<input type="radio"/> S <input type="radio"/> A <input type="radio"/> %
Phase fault		Phase unbalance	
	<input type="radio"/> S <input type="radio"/> A <input type="radio"/> %		<input type="radio"/> S <input type="radio"/> A <input type="radio"/> %
Reverse phase		Ground fault	
	<input type="radio"/> S <input type="radio"/> A <input type="radio"/> %		<input type="radio"/> S <input type="radio"/> A <input type="radio"/> %
In case of no F/S input within setting time		When it passed the operating setting time	

Self-diagnostic function

	<input type="radio"/> S <input type="radio"/> A <input type="radio"/> %	When MC condition input contact point is ON after output contact OFF operating.
	<input type="radio"/> S <input type="radio"/> A <input type="radio"/> %	When MC condition input contact point is OFF, after output contact point ON operating.
	<input type="radio"/> S <input type="radio"/> A <input type="radio"/> %	When the external input contact point "FOR", "REV" is applied at once.
	<input type="radio"/> S <input type="radio"/> A <input type="radio"/> %	EEPROM Fault

Operation and setting

Front view

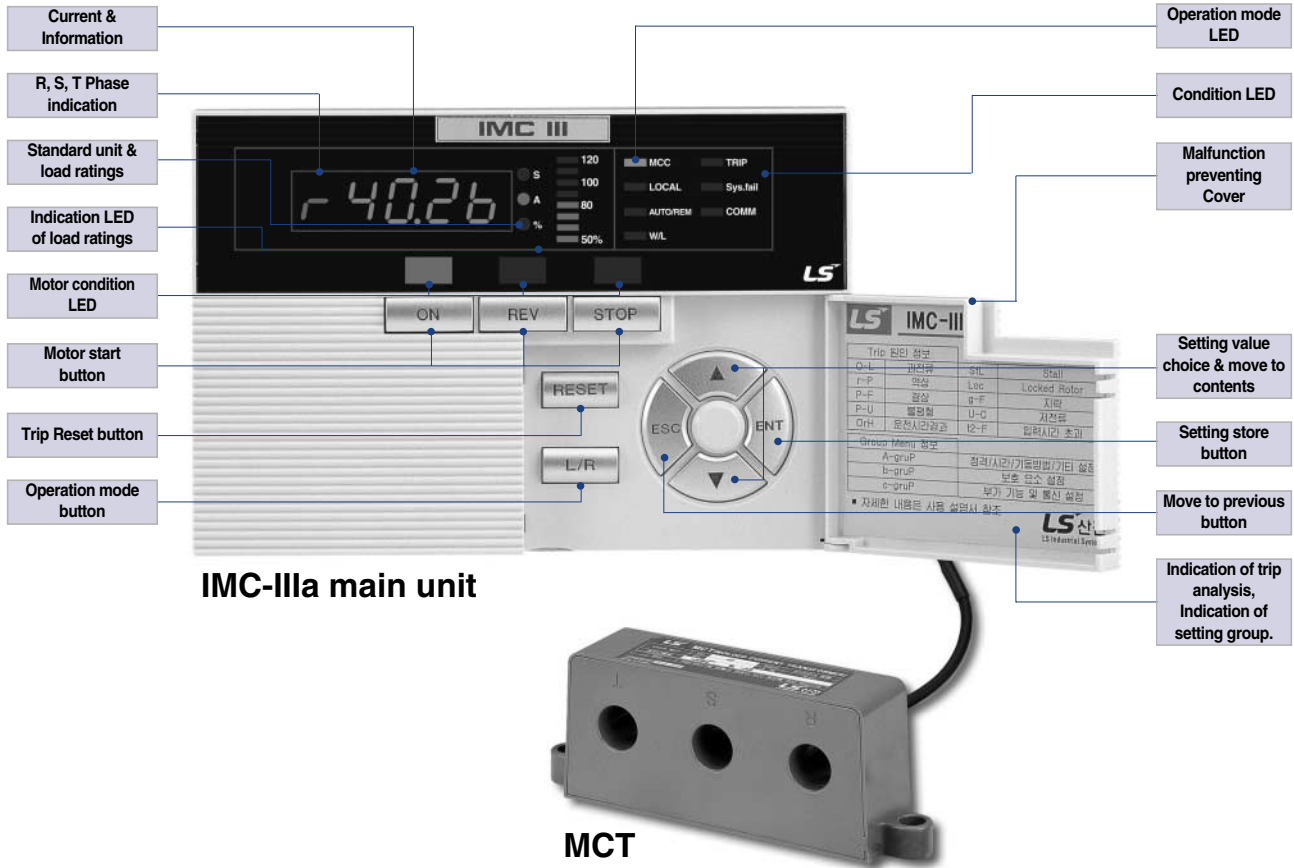

Rear view

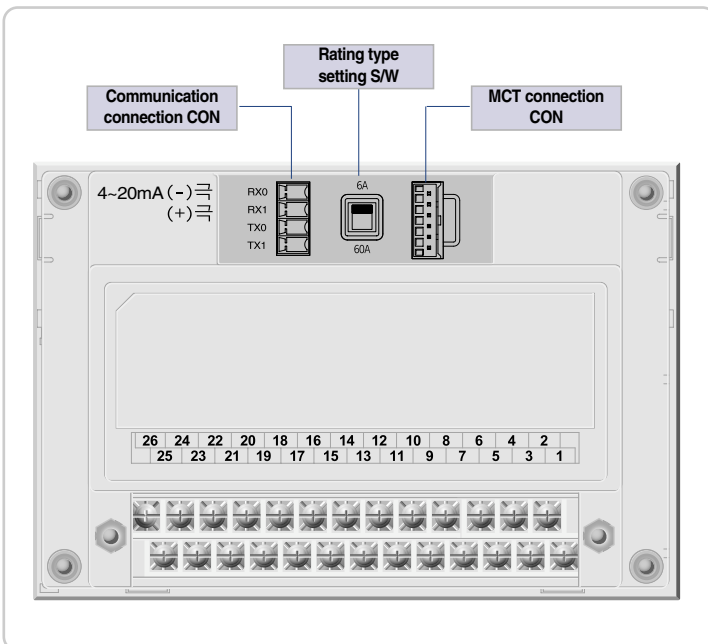

Setting method

- 1) The first stage will be indicated maximum current in normal condition.
- 2) When the UP/DOWN button is pushed, A, B, C group is indicated.
- 3) When user push the ENT button after selecting group, it move to the detail setting contents.
- 4) After selecting contents by pushing UP/DOWN button, if user push the ENT button, the setting value will be stored.
- 5) When UP/DOWN button is pushed, the setting value will change, so that after selecting contents, if you push the ENT button, setting value will be stored.
- 6) After setting, if user push the ESC button, IMC-IIIa will be returned normal operating condition.

Note) 1. Pls note that setting value can be changed during motor operation.
 2. If user did not operate for 10S, Setting value and group setting contents will returned to current indication mode automatically.

Intelligent Motor Controller

Operation and setting

Group	No.	Setting	Indication	Setting value	Default value	Remark	
A. grp	Basic setting	1	Operating Characteristic (Over current protection)		Inu/dEF	Inu	Inverse/Definite time selection
		2	Operating time (Over current protection)		1~60/1sec	60	In case of definite time, motor operating time
		3	Operating delayed time (Over current protection)		1~200/1sec	200	
		4	Setting of rated current		0.5~6/0.1(A), 5~60/1(A)	6 / 60	6/60A selection
		5	CT ratio		0.25, 0.5, 1~200/1	1	Impossible to set in case of selection 60A
		6	Start type selection		dir/y-d/F-r/Ind/lut	dir	Direct, Y-Δ, Reactor, Inverter start
		7	Y operation time		1~120/1sec	5 (Inverter start : 0)	Reactor start time Inverter start delayed time (0~1sec)
		8	Y-D switching time		0.05, 0.1, 0.2(sec)	0.2	
		9	Short time power off compensation time		OFF, 1~20/1sec	OFF	
		10	Re-start time		0~300/1sec	-	9. It can be indicated only in case of short time power stop compensation time
B. grp	Protection function	1	Lock protection		OFF, 200~700/100(%)	OFF	
		2	Stall protection		OFF, 150, 200, 300(%)	OFF	
		3	Phase-fault protection enabled		OFF/On	On	
		4	Unbalance protection		OFF, 30, 40, 50(%)	OFF	
		5	Reverse phase protection		OFF/On	OFF	Only during operation
		6	Under current protection		OFF, 30~70/5(%)	OFF	
		7	Ground fault protection		OFF/On	OFF	OFF setting in case of inverter start
		8	Ground fault operation current		0.1, 0.2, 0.5, 1.0, 1.5, 2.0, 2.5(A)	0.1	7. Indication by ground fault protection selection
		9	Ground fault operation time		0.05, 0.1~1.0/0.1sec	0.05	
		10	Ground fault delay		OFF/On	OFF	
C. grp	Additional function	1	I/O state information		4-segment		Notify the manual
		2	Total operation time		Total operation time checking	Time check, Setting disabled	Day → hour, min (Max.1year : 8760 hour)
		3	Operation time		Operation time checking	Time check, Setting disabled	Operation time → Day → Hour, min (Max 1year : 8760 hour)
		4	Operation time setting		OFF, 10~8760/10(H)	OFF	After reached setting operation time, indicating "OrH"
		5	Contact check		OFF/On	On	MC condition input check (OFF→not indicated Err1,2)
		10	Auto-returning		OFF, 1~20min/1min	OFF	
		11	Communication address		1~255	1	Only indication of communication model
		12	Communication Sped		96, 192, 384	96	bps(×100)
	13	SWAP		OFF/On	On	Floating data frame reverse (3, 4, 1, 2) selection	

Note) Start type selection No.6 of Group A and user contact point mode No.6 of Group C does not set during operating motor because of malfunction.

Rated current setting

- 1) IMC-IIIa rated current can be selected 6A(0.5~6A), 60A(5~60A)
- 2) To select the rated current.
 - ① User has to switch the IMC-IIIa power OFF → ON
 - ② User has to switch the IMC-IIIa ON → OFF
 - ③ Move to the slide switch to the rated current side in the rear side
 - ④ Set the detail current by moving from A setting group to [4.r-C] group in the front side.
 - Setting by motor setting current
 - After finishing motor starting, set the 110~115% of real load current in the load operation condition.

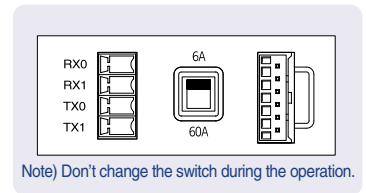

Information

- **Load under 0.5A**
 - Set the CT ratio 0.5 or 0.25 in the [6.ctr]
 - MCT cable penetration increase from 2 times to 4 times
 - Rated current setting range : 0.25~3A(2 times), 0.125~1.5A (4 times)
- **Over 60A load**
 - Usage of external CT
 - CT ratio (1~200) : Maximum 1000A

Operating time setting

- 1) It can be set 1~60s in the A group in [2.O-t]
 - ① In case of selecting inverse time in the [1.CHA]
 - Setting operation time is 600% standard of rated current
 - ② In case of selecting the definite time
 - The standard is over 105% of rated current.
 - User has to set the operation delayed time 1~200s In the [3.d-t] considering motor operating time.

Special function key

Turn the heating capacity into clear and return by force

IMC-IIIa inverse time protects overload fault by sensing the applied current on the motor, trace heating condition of motor. Motor has heating capacity until completed cold status even if . motor stopped. IMC-IIIa accumulates heating capacity values similar with motor. In case of continuous re-start, or generating the trip, it can be tripped by acknowledgement Hot curve through the cumulated heating capacity,

Information

If user want to re-start even if damaged to motor, push the **STOP** + **RESET** button. in conclusion, cumulative heating capacity remove and can be reset.

Fault recording

IMC-IIIa provides fault recording function even if power is OFF. If user push the **ESC** + **ENT** button, user can check the Fault analysis and fault current value. If user push the **RESET** button, fault analysis and fault recording will be deleted.

If there is no string data, it will be indicated "non" And then if user push the **ESC** + **ENT** button, it will come back to normal mode.

Transfer to current indication mode.

If user push the **RESET** button for 2 seconds, it will come back to current indication mode.

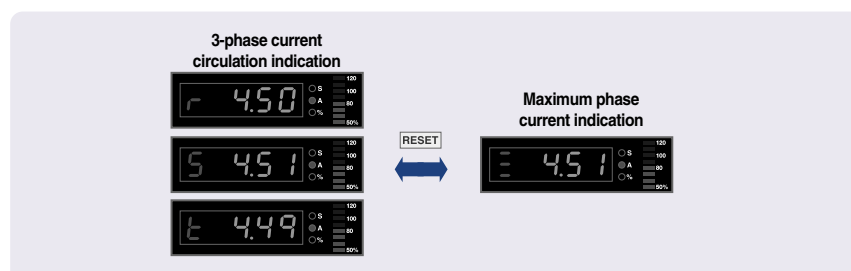

Note) If user push the RESET button for over 10s, IMC-IIIa will come back first manufacturing status. At this time, user has to know that setting and storing value is deleted and comes back first manufacturing status.

Intelligent Motor Controller

Operation and setting

Total operation time

Total operation time check : → → day → → Hour minute

ex) If total operation time is 50hours 50 minutes : → → 2 days → → 2.50(2 hours 50 minutes)

Operation time → → Total operation time → → converse day → → Extra hour, minutes

ex) If operation time is 50 hours 50minutes : → → 50 hours → → 2days → → 2.50 (2 hours 50 minutes)

Operation mode handling method

Operation priority : **Local** > **MCC** > **Auto, W/L** > **Remote**



Local operation panel mode

The local operation mode is the highest priority mode, When the emergency situation generates, it can control motor in the local site. Only in case of closing switch to the local site, motor can be controlled. At that time, Local LED of IMC-IIIa is lighting on, can not be controlled in another modes.



Motor control center mode

This mode is possible to operate in the IMC-IIIa of MCC panel. If MCC LED is lighting up by pushing the button, it's possible to control motor in the IMC-IIIa. At this time, it can not be controlled by in AUTO.

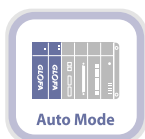

Auto-PLC automatic operation mode.

This mode can provides automatic operation and remote control by PLC, DDC, DCS. If auto / Rem LED lights up, motor is controlled by automatic operation.



Remote- communication operation mode

This mode is for remote monitoring control by Modbus, RS-485. If Auto/Remote LED lights up, It's possible to communicate with Modbus/RS-485 and also check the 3phase value, fault value, various data.

Note) 1. 4~20mA output model can check only current Value through the Analog communication(4~20mA)
2. At this operation mode, It's impossible to operate the motor controls.

Wiring method

Direct start sequence

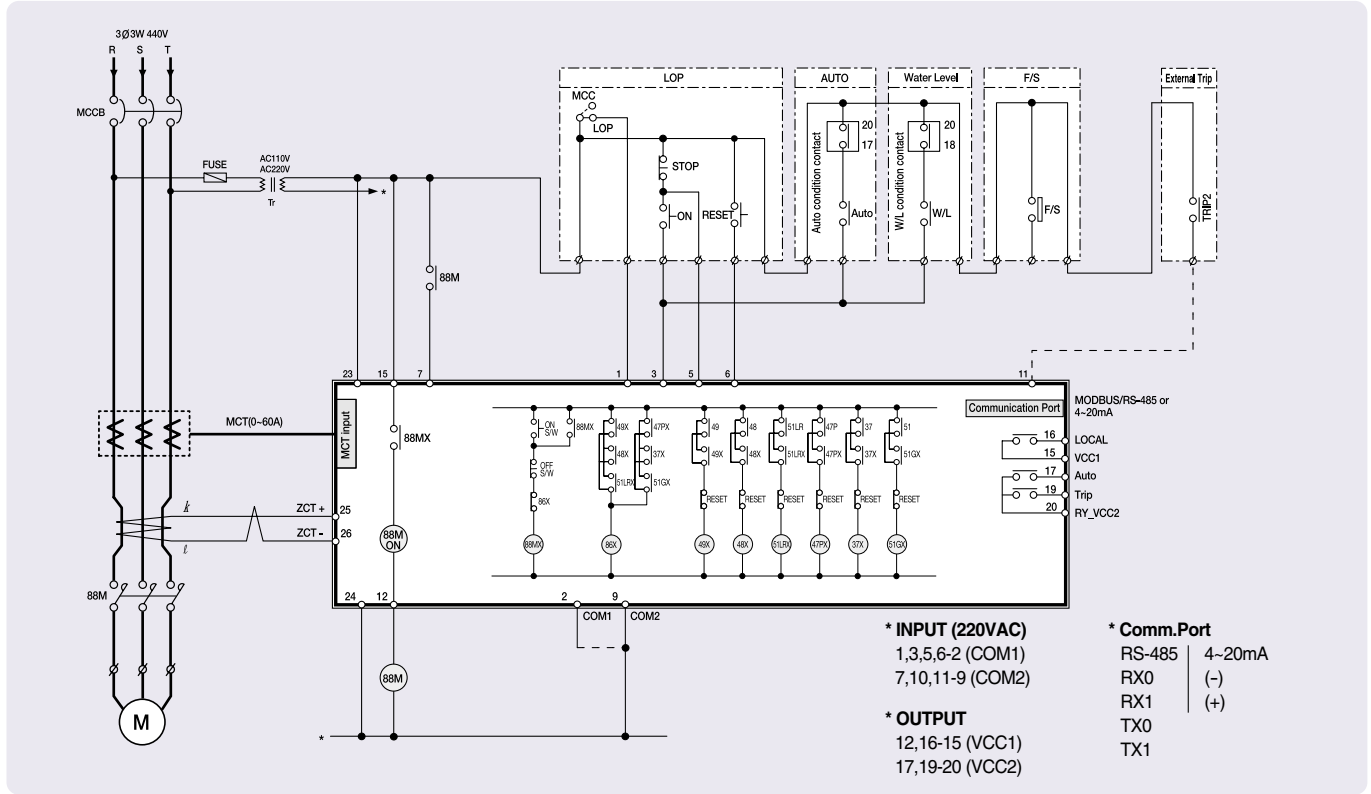

Y-Δ start

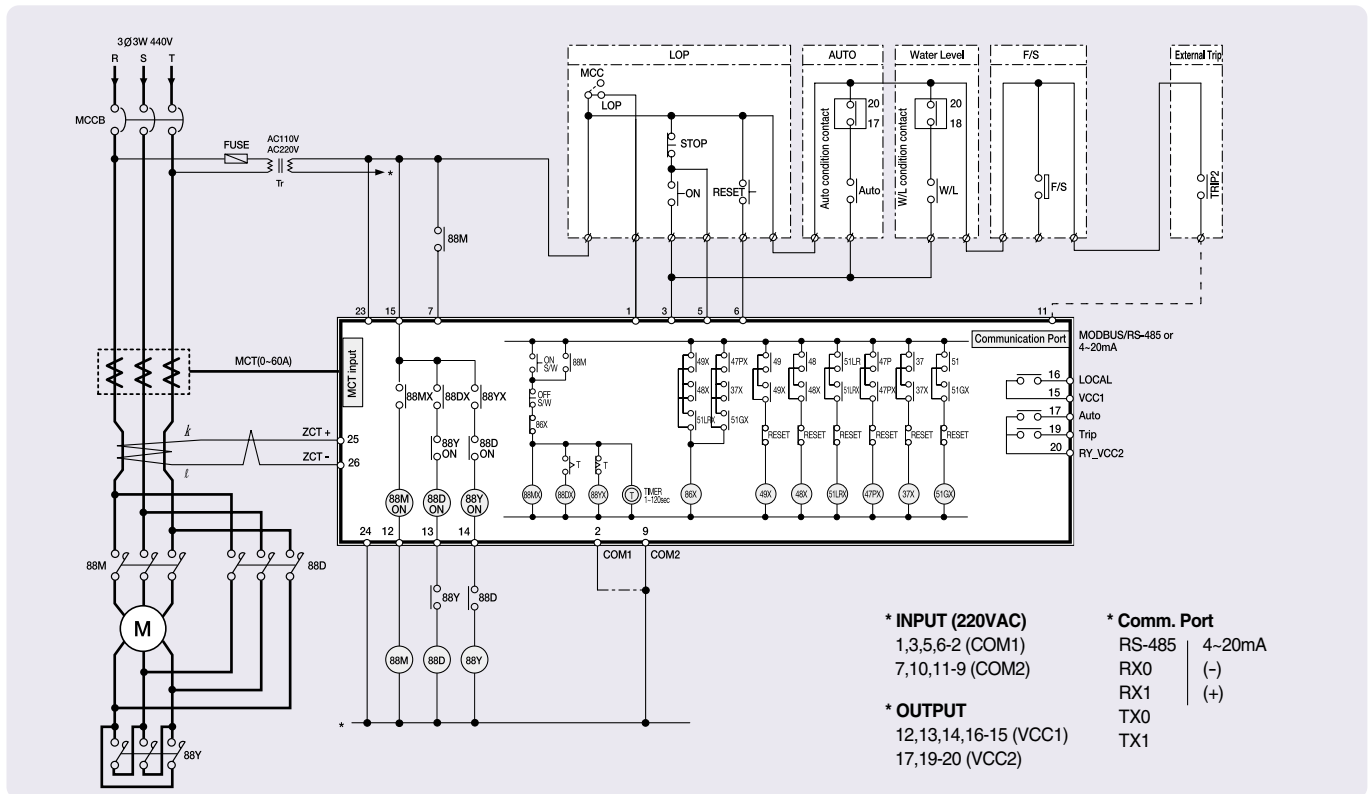

Intelligent Motor Controller

Wiring method

For/Rev start

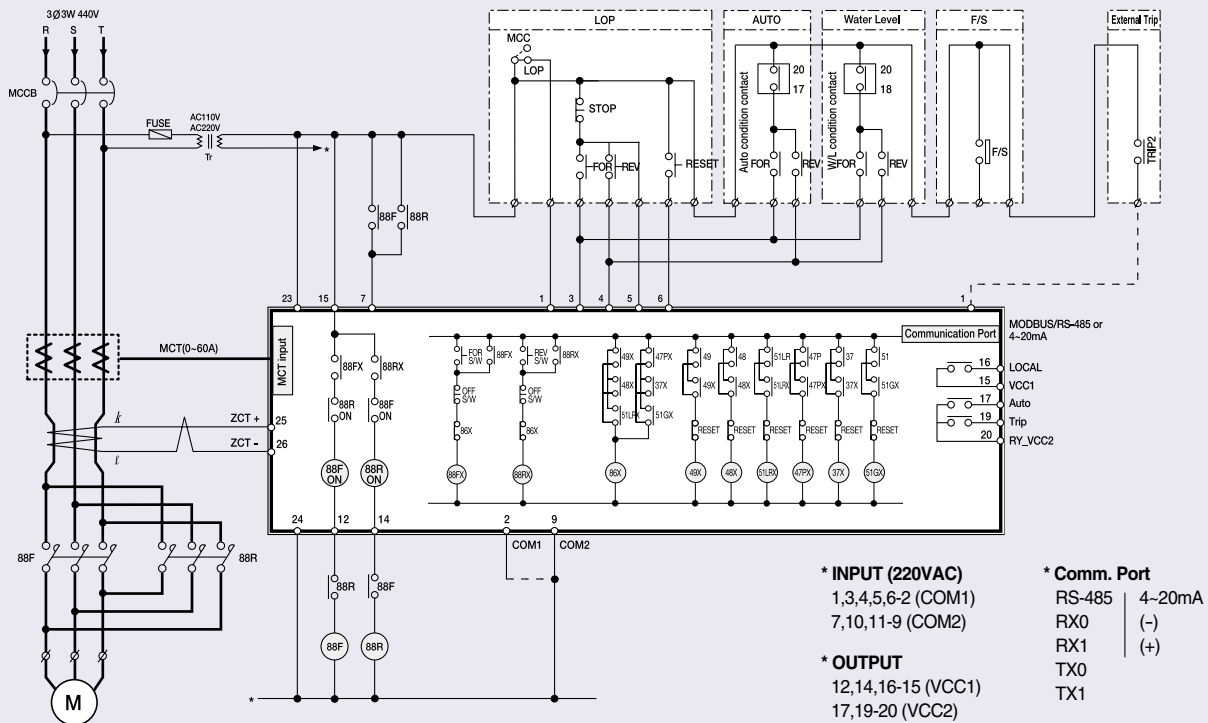

Reactor start

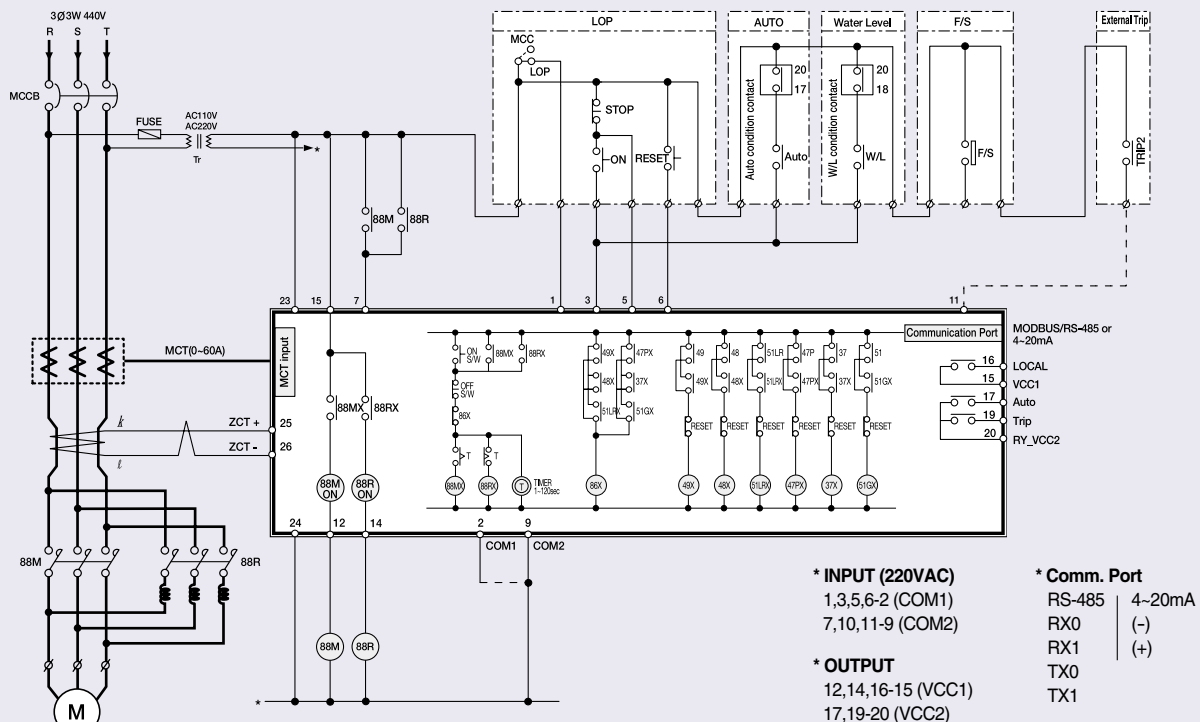

Inverter start

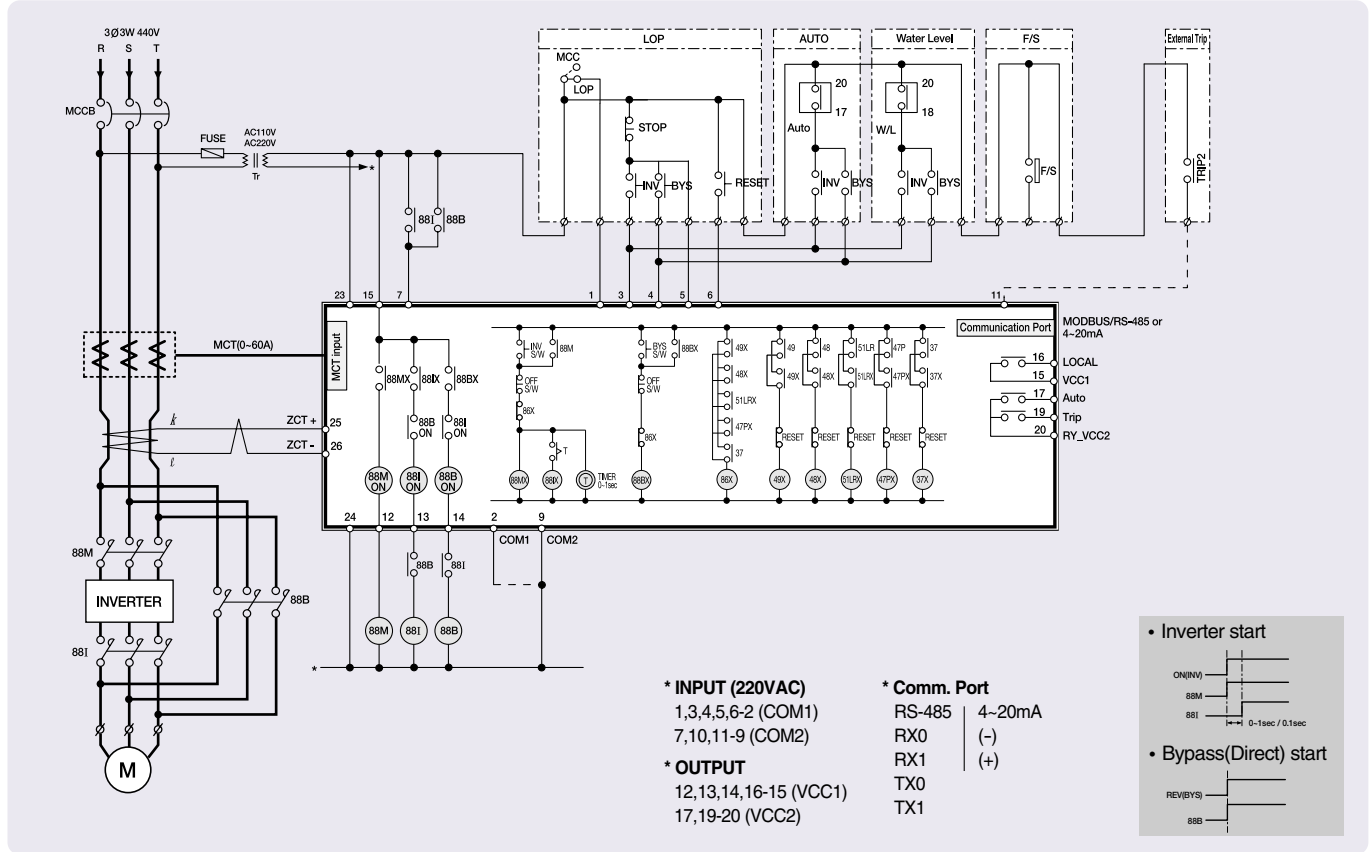

Terminal number

Terminal No	Explanation	Terminal No	Explanation
1	LOP selection input	14	Y-start/Reverse rotation/Reactor/Bypass contact point output
2	COM1(1, 3, 4, 5, 6)	15	VCC1(12, 13, 14, 16)
3	ON input	16	LOP condition output
4	Reverse rotation ON input(Bypass)	17	Auto condition output
5	Stop input	18	Water level condition output
6	Reset input	19	TRIP output(1a)
7	MC condition input	20*	VCC2(17, 18, 19, 21, 22)
8	F-S mode input	21*	ON delay timer output(t-d, F-S mode)
9	COM2(7, 8, 10, 11)	22	OFF delay timer output(t-d, F-S mode)
10	External trip1 input	23	Control power(AC110V or 220V)
11	External trip2 output	24	Control power(AC 110V or 220V)
12	ON output	25	ZCT input(k)
13	△start/Inverter contact output	26	ZCT input(l)

* Normal mode
 20-21 : Operation alarm ("OrH") output
 20-22 : not in use

Intelligent Motor Controller

System configuration

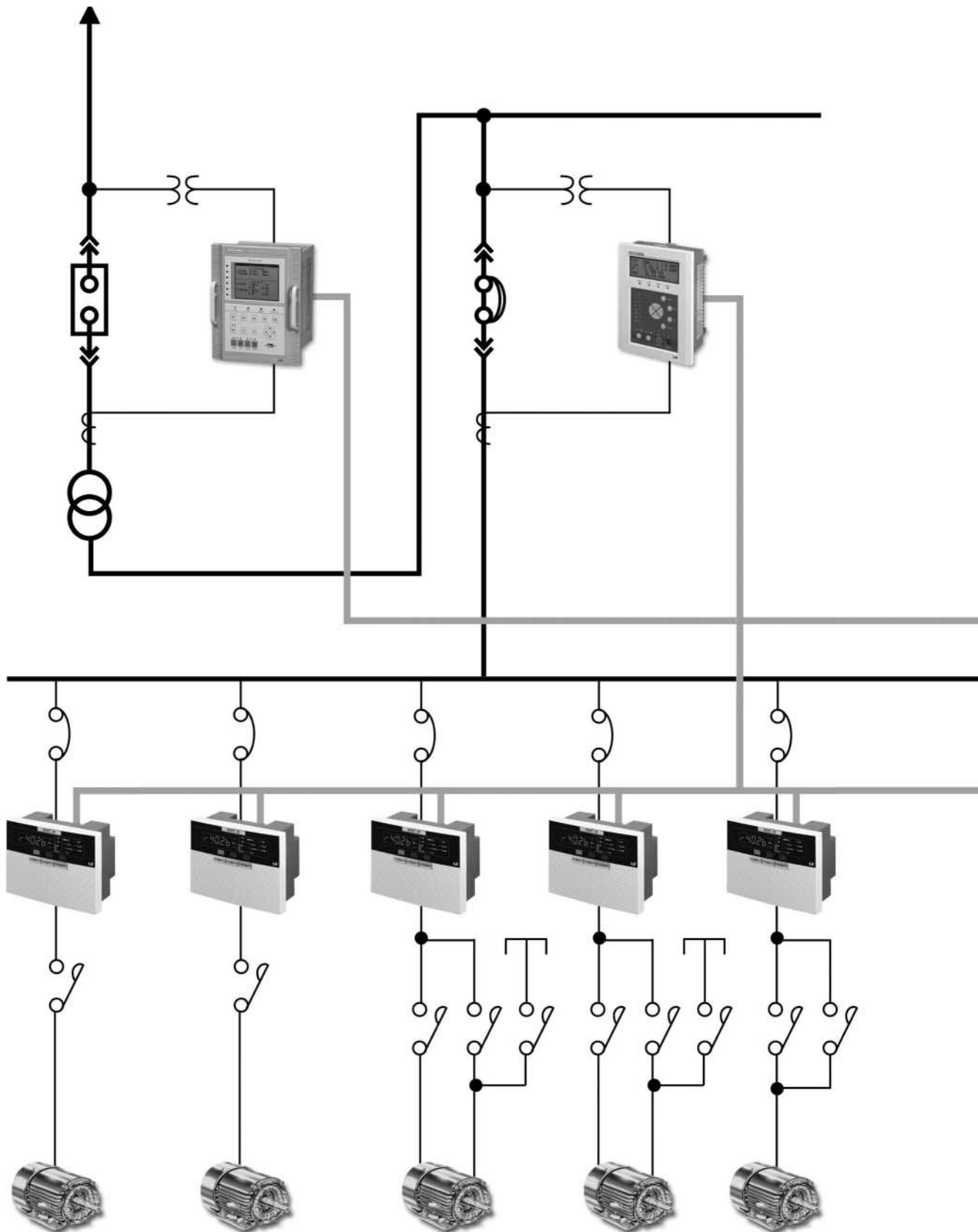

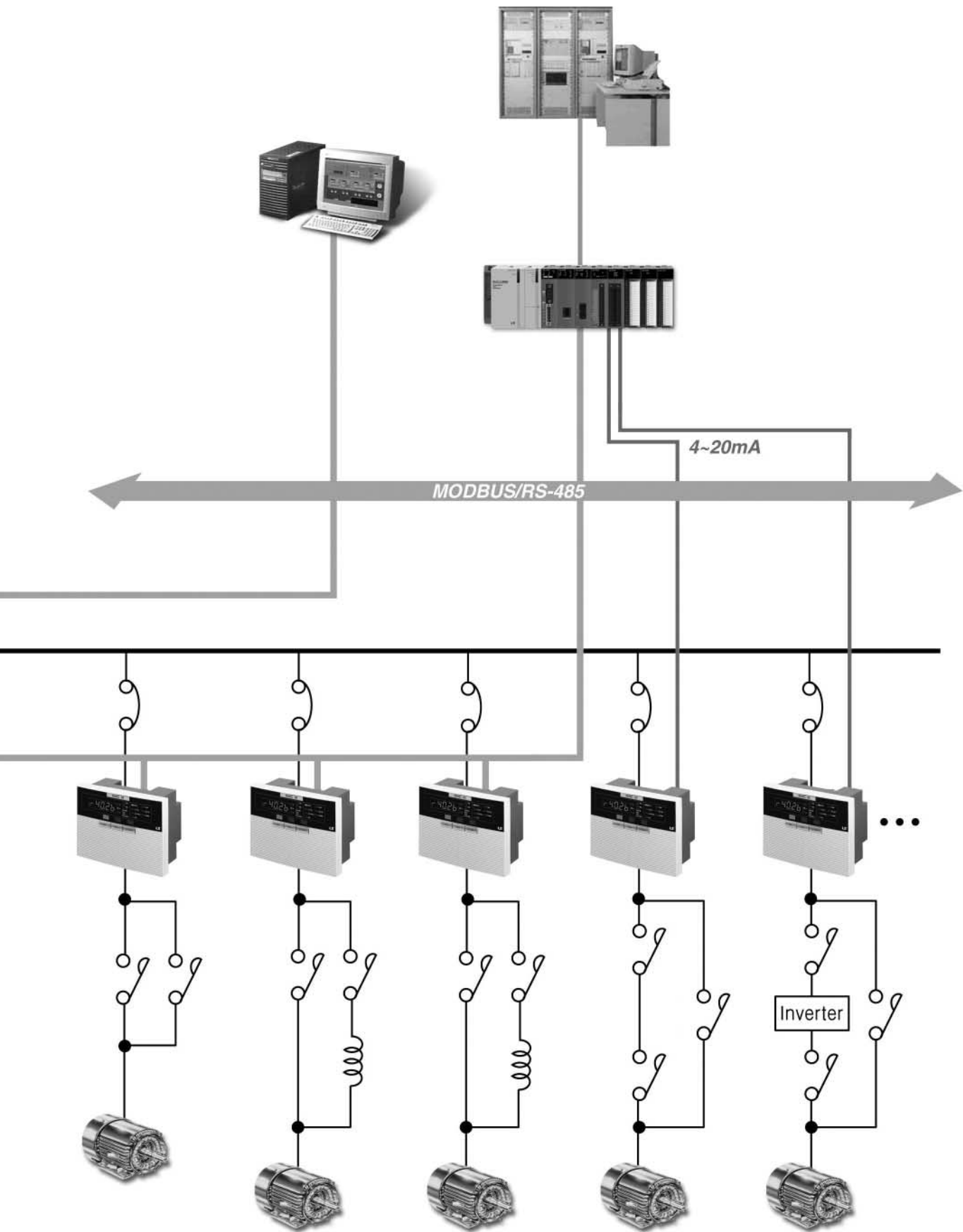

Intelligent Motor Controller

Accessories

ZCT(Zero-phase current transformer)

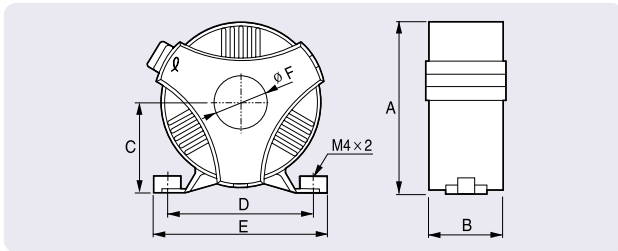

Contents	Inside diameter (mm)	Zero phase current transformer ratio	Weight (kg)
LZT-025(I)	25	200mA/0.1mA	0.5
LZT-040(I)	40		0.8
LZT-080(I)	80		0.4

Dimension(mm)	A	B	C	D	E	∅F
LZT-025(I)	81	43	43.5	68	81	25
LZT-040(I)	101	43	53.5	88	101	40
LZT-080(I)	146	43	76	133	146	80

Note) This product is only for IMC, and user has to use this ZCT for protection ground fault.

SCT(3CT)

1CT

3CT(Combination of 1CT 3EA)

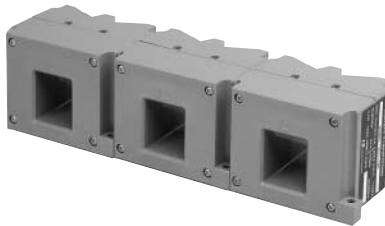

Dimension

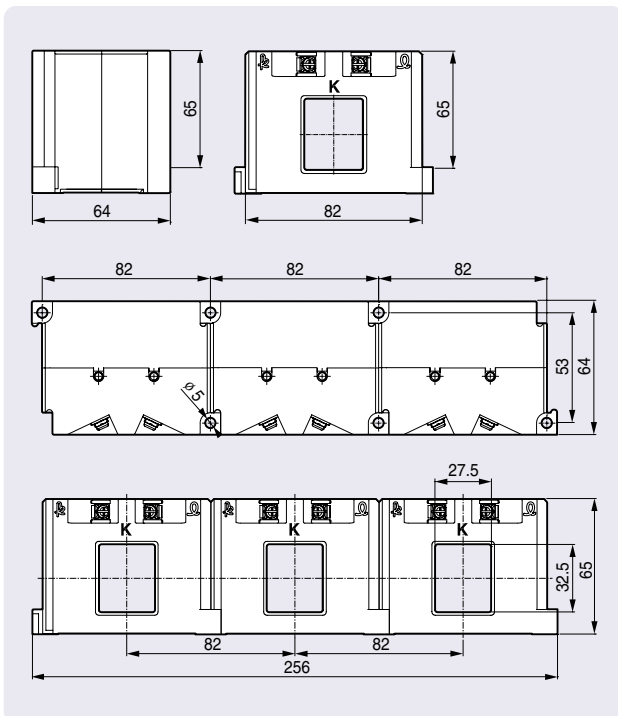

Ratings

Model		Spec.
Current transformer ratio	SCT-100	100:5A
	SCT-150	150:5A
	SCT-200	200:5A
	SCT-300	300:5A
	SCT-400	400:5A
Class		1.0
Burden		5VA
Insulated voltage		AC 600V
Insulated internal pressure		2kV
Insulation resistance		10M Ω (DC 500V Megger)
Mounting		Panel

In case of MCT combination

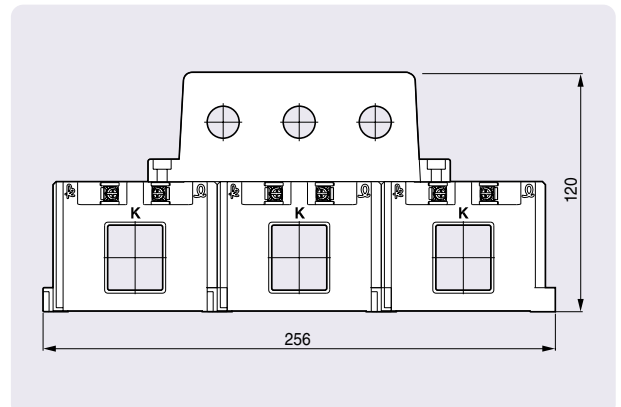

Note) 1. This product is only for EMPR, IMC, user must not use for other service
2. Pls order each 3EA with IMC-IIIa, because this product is 1CT type.

Dimension & Ordering

Dimensions

IMC-IIIa main unit

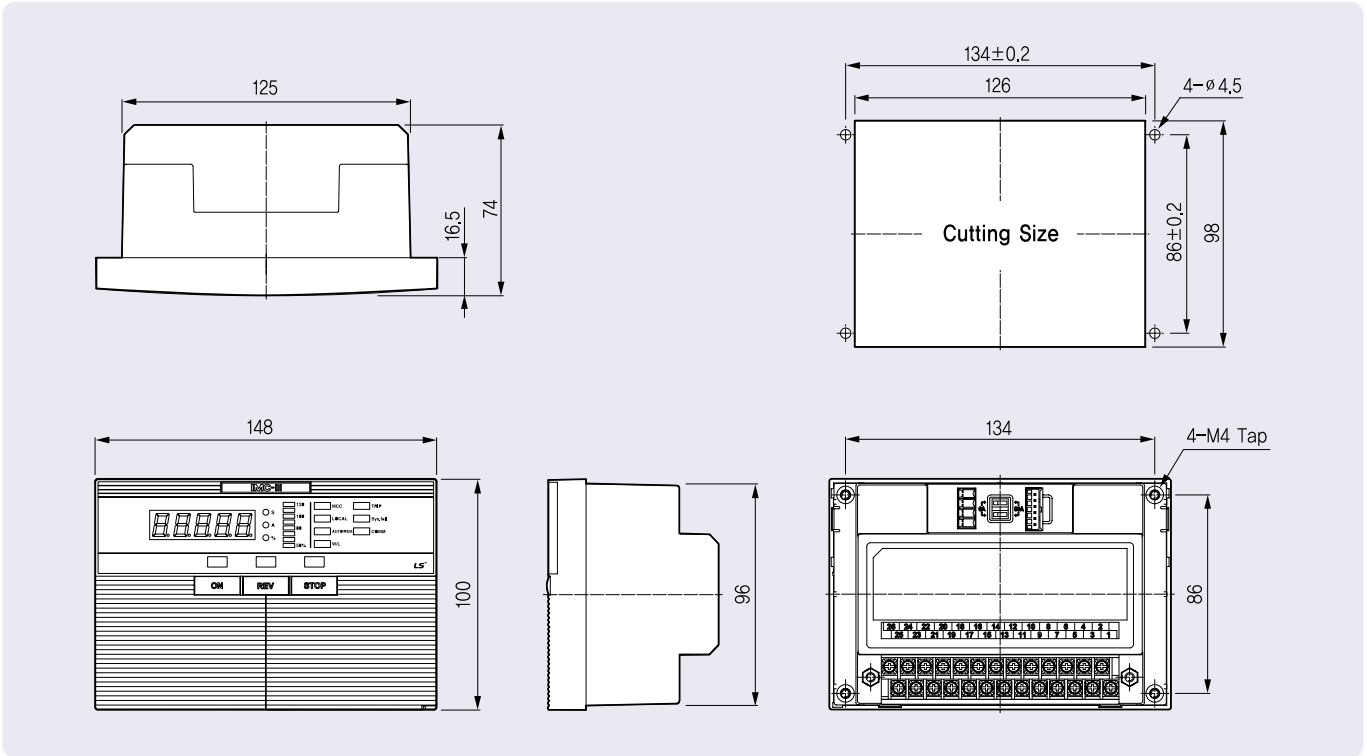

MCT

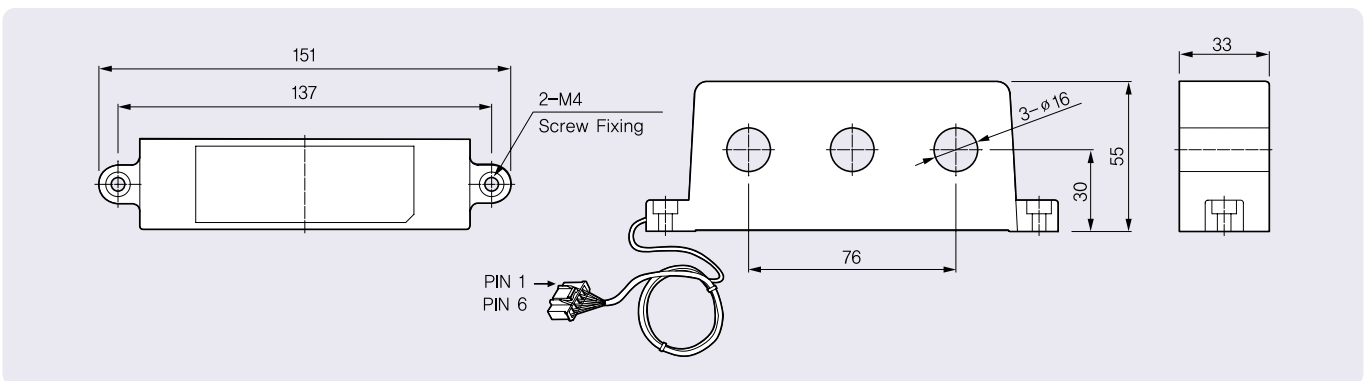

Ordering

IMC-III

Function		Communication		MCT cable length		Operation and control power		Frequency	
a	Standard	NO	Normal (No communication)	2M	2m	AC 110V		50/60Hz	
-	Option	M485	Modbus/RS-485	4M	4m	AC 220V			
		A420	Analog 4~20mA						

GIMAC-V



Digital Integrated Metering & Control Device Power Quality Meter
Automatic Power Factor Controller



IEC 60255, KEMC 1110

GIMAC-V is composed of Digital Integrated Metering & Control Device and Automatic Power Factor Controller(APFC).

Digital Integrated Metering & Control Device provides various functions including various measurement with high-precision, power quality, harmonic analysis, circuit breaker control, DI monitoring and event recording in the distribution system.





Main features	O-1-4
Ratings and functions	O-1-7
External view and MMI control	O-1-9
Contact configuration and operation	O-1-10
Wiring	O-1-11
System configurations	O-1-13
Dimensions and ordering	O-1-14



GIMAC-V

Digital Integrated Metering & Control Device
Power Quality Meter
Automatic Power Factor Controller



GIMAC-V is composed of Digital Integrated Metering & Control Device and Automatic Power Factor Controller(APFC).

Digital Integrated Metering & Control Device provides various functions including various measurement with high-precision, power quality, harmonic analysis, circuit breaker control, DI monitoring and event recording in the distribution system.

According to the use of nonlinear loads that are sensitive to power quality the occurring of harmonics increases , which causes abnormal behavior of the devices and industrial damages. In order to minimize the economic loss arised from unexpected events such as equipment abnormal operation, production disruptions, process confusing due to harmonic generation and electro-magnetic phenomena. GIMAC-V provides storing power quality factors such as Sag, Swell, Interruption, Transient as well as measurement fuctions such as voltage, current, phase, frequency, harmonics of each phase.



Main features

Color graphic LCD & Touch screen

Increased visibility of measuring of the power system and real-time waveform through graphic processing by using a color touch graphic LCD

- Comprehensive measurements display with high visibility
- Real-time waveform display and capture
- harmonic analysis display

Language selection and User selective menu

- Korean/English selecting on screen menu
- Customizing frequent monitoring menu

GIMAC-V Manager

The set contents can be downloaded/uploaded by USB cable, therefore maintenance and data inquiry are very convenient .

● Function

- USB communication with PC
- Demand trends, events inquiry and DB management
- Instrument settings and status inquiry
- Measurement, electricity demand, harmonic monitoring
- Displays of electricity by vector or trend graph
- CB, DO, Remote / Local, Auto / Manual control
- General, quality and transient events can be queried Waveform data stored in a file with the Comtrade format

● System Requirements

- Intel Pentium 3 or more IBM-PC compatible PC
- 512MB or more memory
- 1024 × 768 or higher resolution VGA card
- MS Windows 7/2000/XP
- 1G or more hard disk space
- USB 1.0 or higher port

● Installing Manager program

- USB Mini 5P Cable
- Program : download from www.lsis.biz



Support 3-way communication

Two RS485 and one Ethernet communication ports are provided to support independent communication through each port

- 2 ports for MODBUS RTU (RS-485)
- 1 ports for MODBUS TCP (10/100 Base-Tx)

Automatic Power Factor Control (APFC), optional

Automatic power factor control for upto 8 capacitor banks by setting capacitor capacity and control condition

- Combination control : In case the capacitance is set, it calculates the required reactive power at current factor and controls the capacitors to comply with the set capacity
- Circular control : If the capacitance is not set, it opens closed capacitors and then closes those from lately opened one.

Enhanced power quality (PQ) measurement function

- Sag, Swell, Interruption Analysis /Measurement, and 512 Events storable
- Harmonic analysis spectrum 63rd analysis (THD, TDD, k-factor, Crest Factor)
- Current and voltage measurements with accuracy 0.2%
- Power, energy measurements with accuracy 0.5 Class (IEC 62053-21, 22)
- 250 PQ Event waveform data can be stored

Transient Wave / Event storage / Inquiry

- Transient wave saving up to 20 with 1,024 sampling (60Hz 16.28usec) per cycle
- Power Quality, Transient waveform and DI inputs displayed
- Analysis of Comtrade format files

Power Quality / Transient function

Item	Setting	range Remarks
Sag	40 ~ 90%	- PQ Event : Saving max. 512 events of Time of occurrence, Pickup and Max./Min. voltage
Swell	110 ~ 200%	- PQ Wave : Saving at least 250 events of max. 60 cycles of voltage / current waveforms
Interruption	10 ~ 30%	- When PQ event occurs the output of DO is settable and Alarm LED blinks
Transient Voltage	60~150V	- Event: Saving max. 512 events of Time of occurrence, dV/dt and Max./Min. voltage
		- Saving at least 20 of Wave 1 cycle (1024 Sampling) of the voltage/current waveform
		- When event occurs the output of DO is settable and Alarm LED blinks - Transient perceived time: 16.276 us (at frequency 60Hz)

* The setting range is a percentage of the secondary rated voltage (%).
* Wave stored as Comtrade files can be analyzed in detailed.

Main features

A variety of measurement items and monitoring

- Wide voltage input range (AC 10 ~ 452V, 40 ~ 70Hz)
- Voltage/current 0.2% and power/energy 0.5 Class accuracy achieved
- 105 kinds of measurement elements provided including voltage and current harmonics upto 63ch., THD, K-Factor and Crest Factor
 - Wave capture of voltage and current waveforms
 - Check the wiring via VECTOR with color LCD
 - Color display of DIO operation status

Statistics and Trend

- Saving max. values of the 43 measurement elements, min. values of the 19 measurement elements, preceding demand, the max/min /avg value of the instantaneous value out of the preceding demand time, and max/min demand value.
- For the selected 10 measurements elements Trend data for 110days (15min basis) can be stored and displayed in Graph for trend analysis
- Demand time : 1, 2, 5, 10, 15, 20, 30, 60 min

Other functions

- Breaker status monitoring and SBO control
- 512 events storable including equipment status changes, RESET, Clear, etc
- Incorrect wiring on the grid, the frequency trouble and self-test
- Analog 4 ~ 20mA input option

Functional Block Diagram

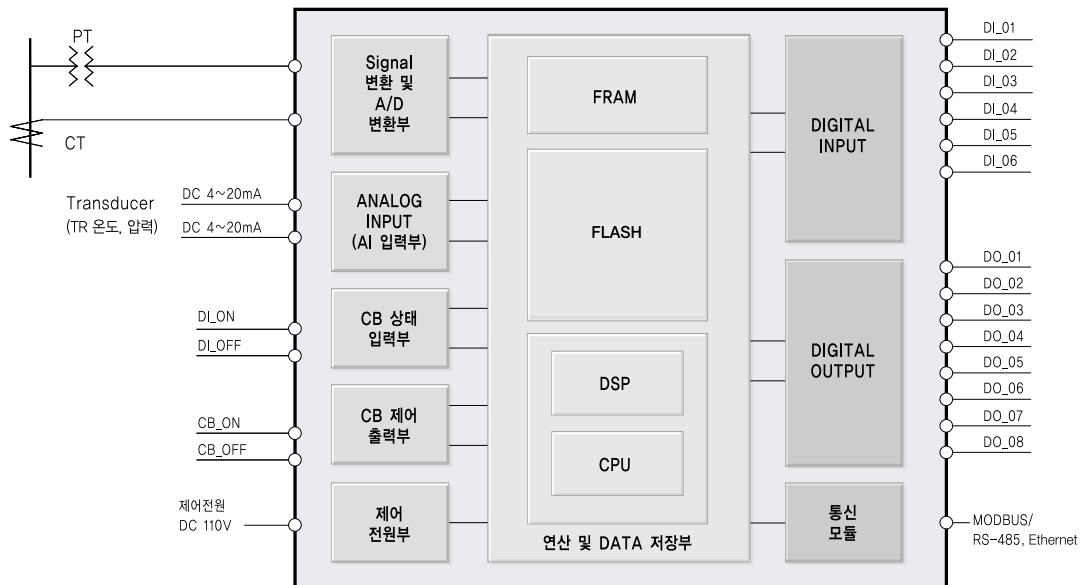

<Oscillograph view>



<Voltage trend view>

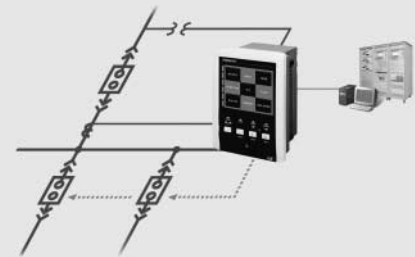

Ratings and functions

Product Rating

Item		Descriptions
Wiring system		3P4W, 3P3W(Y), 3P3W(OPEN-DELTA), 1P3W, 1P2W
Rated frequency		60Hz or 50Hz
Measuring voltage range		10 ~ 452V(Va, Vb, Vc - Vn voltage at both terminals)
Measuring current range		0.05 ~ 6A
PT, CT input burden		each less than 0.2VA
Rated Controlled power		DC 110V ±20%
Digital Input Power		DI 6 Point (DC 110V)
Power Consumption		20W or less normally, 30W or less at operation
DO rated output	DO 1~7 RELAY	AC250V 5A, DC30V 5A
	DO 8 RELAY (C contacts)	AC250V 12A DC24V 12A
	CB_ON, CB_OFF RELAY	AC230V 16A, DC30V 16
Operating temperature		-10°C ~ 55°C
Storage temperature		-25°C ~ 75°C
Operating humidity		80% or less (No condensation)
Altitude		Less than 2,000 m above sea level
Insulation Resistance Over		DC 10M Ω / 5M Ω
Insulation Voltage		AC 2kV (1kV) / 1min
Impulse Voltage		AC 5kV (3kV) / 1.2×5Q μ s
Overload withstand	Current	2 In for 3 hours, 20 In for 2 seconds
	Voltage	1.15 Vn for 3 hours
Fast Transient Disturbance		Power Input 4kV, Other Input 2kV (Analog Input 1kV)
ESD(Electrostatic Discharge)		Air 8kV, Contact 6kV
Standards		IEC 60255, IEC 61326, IEC 61000-4, KEMC 1110
Communication type	MODBUS-TCP	<ul style="list-style-type: none"> • MODBUS TCP(10/100 Base-Tx) : 1Port, • Communication speed : 10/100 MBps, Star Type, UTP (CAT.3, CAT.5) • Communication distance, max. 100m (HUB to terminal)
	MODBUS-RTU	<ul style="list-style-type: none"> • MODBUS RTU(RS485) : 2Ports • Operation mode Differential, Universal 9,600 / 19,200/38,400bps • Communication distance, max 1.2km, Universal RS-485 Shielded Twist 2-Pair cable • Transmission system, max Half-Duplex, output voltage -7V ~ +12V
Size / Weight (W×H×D)		190×255×116(mm), 3.6kg

※ Avoid places with vibration, shock, dust, moisture, corrosive, gas, etc.

Automatic Power Factor Controller (APFC)

Type		GIMAC-V AP
BANK setting	BANK number	0-8
	Alarm number	0-1
Capacitor capacitance setting		None ~ 999MVA
Alarm contact setting		Setting one of extra contact out of DO_01~ DO_08
Capacitor closing delay time		10~ 300sec / 1sec
Dead time (time for charge or discharge)		10~ 300sec / 1sec
Maximum power factor setting		0.95~ 1~ -0.90 (- : indicating lead phase)
Minimum power factor setting		0.80 ~ 0.95
Alarm power factor setting (Alarm occurred)		0.00 ~ 0.90
Event occurrence Under Voltage and control Over PF	Low Current	Set whether to get EVENT occurred or set the control in case the average current of 3 phase is 1A
	Under Voltage	Set whether to get EVENT occurred or set the control in case phase voltage (3 phase 3 wire, open delta , line voltage)
	Over PF	Set whether to get EVENT occurred or not when over Max. PF
	Under PF	Set whether to get EVENT occurred or not when over Min. PF
Power Factor control	Over Volt THD	Set whether to get EVENT occurred and BANK control or not when THD is above the setpoint
	Automatic control	Auto
	Manual control	Manual
	Combination control	In case all capacitances are set
	Circulation control	Capacitor In case capacitances are not set - Opening the closed one first and closing the opened last

Digital Integrated Metering & Control Device/Power Quality Meter/Automatic Power Factor Controller

Ratings and functions Wiring

Measurement item & Accuracy rate

Type	Measuring item	Detailed measuring item	Accuracy
Voltage	Line voltage	Vab, Vbc, Vca, Vavg ^(Note)	0.2%
	Phase voltage	Va, Vb, Vc, Vnavg	0.2%
	Normal, reversed-phase voltage	V1, V2	-
	Crest Factor	Vab, Vbc, Vca, Va, Vb, Vc	-
Current	Phase current	Ia, Ib, Ic, Iavg	0.2%
	XPhase current	Ix	0.2%
	Normal, reversed-phase currents	I1, I2	-
	Crest Factor	Ia, Ib, Ic	-
Phase	Line voltage	$\angle Vab, \angle Vbc, \angle Vca$	0.5°
	Phase voltage	$\angle Va, \angle Vb, \angle Vc$	0.5°
	Phase current	$\angle Ia, \angle Ib, \angle Ic, \angle Ix$	0.5°
Electricity	Active power	Pa, Pb, Pc, ΣP	0.5class
	Reactive power	Qa, Qb, Qc, ΣQ	0.5class
	Apparent power	Sa, Sb, Sc, ΣS	0.5class
Electricity energy	Active energy	WHa, WHb, WHc, ΣWH	0.5class
	Reactive energy	VARHa, VARHb, VARHc, $\Sigma VARH$	0.5class
	Reverse active energy	rWHa, rWHb, rWHc, ΣrWH	0.5class
	Reverse reactive energy	rVARHa, rVARHb, rVARHc, $\Sigma rVARH$	0.5class
	Apparent energy	VAHa, VAHb, VAHc, ΣVAH	0.5class
freq	Frequency	F(Hz)	0.1%
Power Factor	Power Factor(PF)	PFa, PFb, PFc, ΣPF	phase accuracy
	1st harmonic power factor (DPF)	DPFa, DPFB, DPFC, ΣDPF	
Harmonics	Line voltage	Vab, Vbc, Vca 2~63th Harmonics	-
	Phase voltage	Va, Vb, Vc 2~63th Harmonics	-
	Phase current	Ia, Ib, Ic 2~63th Harmonics	-
	THD	Vab, Vbc, Vca, Va, Vb, Vc, Ia, Ib, Ic	-
	TDD	Ia, Ib, Ic	-
	K-FACTOR	Ia, Ib, Ic	-
AI	4~20mA	AI01, AI02	0.5%

Note : Average of line voltage

External view and MMI control

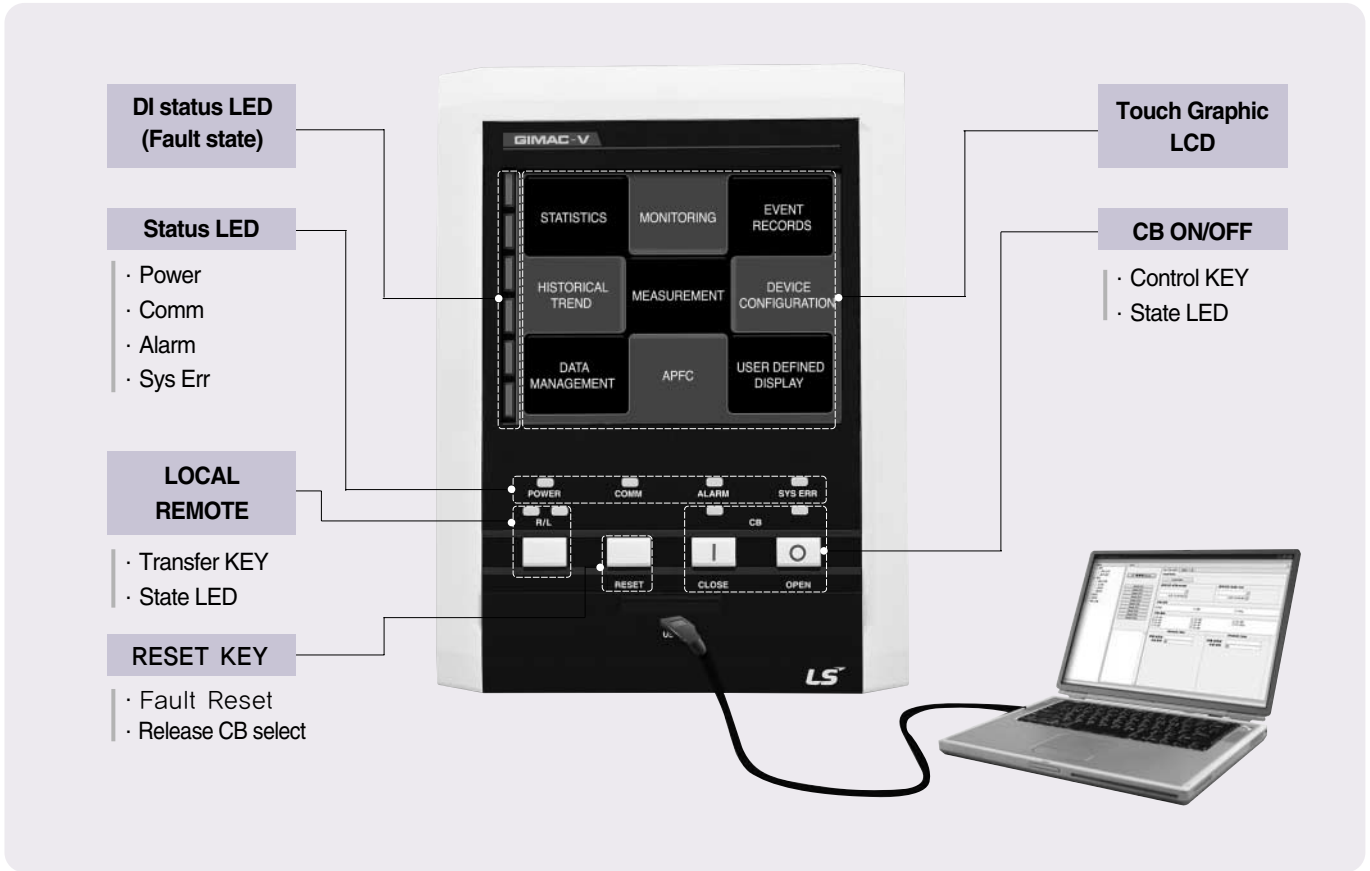

MMI control

STATISTICS	MONITORING	EVENT RECORDS	HISTORICAL TREND	MEASUREMENT	DEVICE CONFIGURATION	DATA MANAGEMENT	APFC
GENERAL MAX VALUE	DI/DO STATUS	GENERAL EVENT RECORDS	TREND1	OVERVIEW	WIRING CONFIGURATION	MEASUREMENT CLEAR	OVERVIEW
GENERAL MIN VALUE	AI STATUS	PQ EVENT RECORDS	TREND2	VOLTAGE	PT CONFIGURATION	STATISTICS MEASUREMENT CLEAR	PF CONFIGURATION
HARMONIC MAX VALUE		TRANSIENT EVENT RECORDS	TREND3	CURRENT	CT CONFIGURATION	HISTORICAL TREND DATA CLEAR	TIME CONFIGURATION
PREVIOUS DEMAND VALUE			TREND4	PHASE	LANGUAGE SELECT	DO COUNTS VIEW & CLEAR	BANK DO CONFIGURATION
MAX VALUE IN PRE-DEMAND			TREND5	POWER	MODBUS-RTU CONFIGURATION	DEVICE INFORMATION	BANK CONDENSOR CONFIGURATION
MIN VALUE IN PRE-DEMAND			TREND6	ENERGY	MODBUS-TCP CONFIGURATION	PASSWORD RESET	EVENT CONFIGURATION
MAX DEMAND VALUE			TREND7	FREQUENCY/POWER FACTOR	POWER QUALITY CONFIGURATION	DEVICE LED TEST	
MIN DEMAND VALUE			TREND8	HARMONIC DIAGRAM	TREND CONFIGURATION	ALL DATA CLEAR	
			TREND9	OSCILLOGRAPH	DI CONFIGURATION	TOUCH CALIBRATION	
			TREND10		DO CONFIGURATION		
					TIME CONFIGURATION		
					DEMAND TIME CONFIGURATION		
					SECURITY CONFIGURATION		
					USER DEFINED DISPLAY		

* Display by user editing

Contact configuration and operation

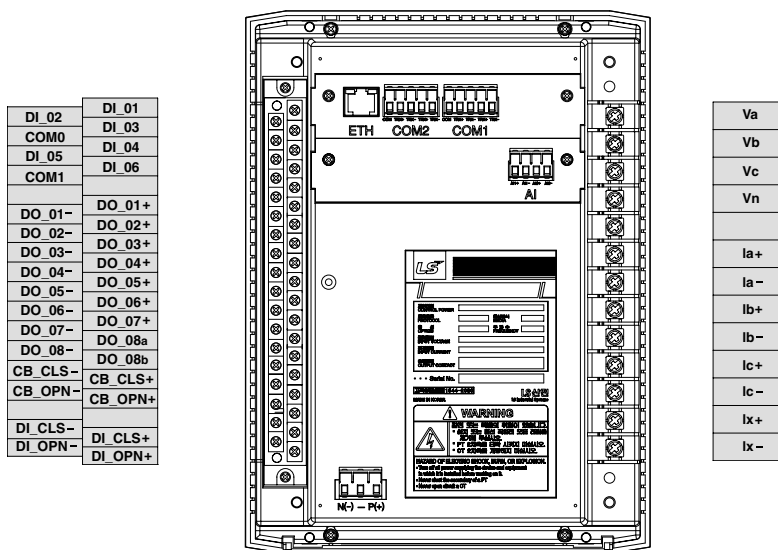

Input and output contact configuration

Terminal Description	Setting by model(Example)		Change of use
	GIMAC-V NO	GIMAC-V AP	
DI_CLS+, DI_CLS- DI_OPN+ DI_OPN-	CB CLOSE State input_52a CB OPENState input_52b		Unchangeable
DI_01-06	FAULT-CAPTURE	DI-NONE	
CB_CLS+, CB_CLS- CB_OPN+, CB_OPN-	CB CLOSE Output CB OPEN Output		Unchangeable
DO_01+, DO_01- DO_02+, DO_02- DO_03+, DO_03- DO_04+, DO_04- DO_05+, DO_05- DO_06+, DO_06- DO_07+, DO_07- DO_08a, DO_08-, DO_08b	SAG SWELL INTERRUPTION TRANSIENT DI LATCH NONE LOCAL/REMOTE	For BANK control For BANK control For BANK control For BANK control For BANK control For BANK control For BANK control ALARM	※ Set as required. Factory setting of DO is NONE

Operations by DI setting

DI Setting	At normal	Fault (DI input)	RESET after		Removal of fault after RESET		Waveform storage (at the point of DI)
			Fault removal	RESET	RESET	Fault removal	
FAULT-CAPTURE	Off	Flickering (red)	Flickering (red)	Off	On (red)	Off	○
FAULT-NONE							×
DI-CAPTURE	Off	On (yellow)	Off	-	-	Off	○
DI-NONE							×

Operations by DO setting

DO	Setting	Operation	Return condition
DO_01 ~ DO_08	NONE	-	-
	SAG	Output in the event of SAG EVENT of PQ	Return by FAULT RESET
	SWELL	Output in the event of SWELL EVENT of PQ	Return by FAULT RESET
	INTERRUPTION	Output in the event of INTERRUPTION EVENT of PQ	Return by FAULT RESET
	TRANSIENT	Output in the event of TRANSIENT EVENT of PQ	Return by FAULT RESET
	DI	If corresponding DI is in ON state	If DI is in OFF state
	LATCH	If corresponding DI is in ON state	If DI is in OFF state and FAULT is RESET
DO_08	APFC ALARM	Output in the event of Alarm of APFC	If FAULT is RESET or ALARM is relieved
	APFC BANK	Output in the event of APFC's closing condition is satisfied	If APFC's opening condition is satisfied or opening command is entered by communications/KEY
DO_08	LOCAL/REMOTE	Output in the state of REMOTE and Return at LOCAL state	

Wiring

3P3W

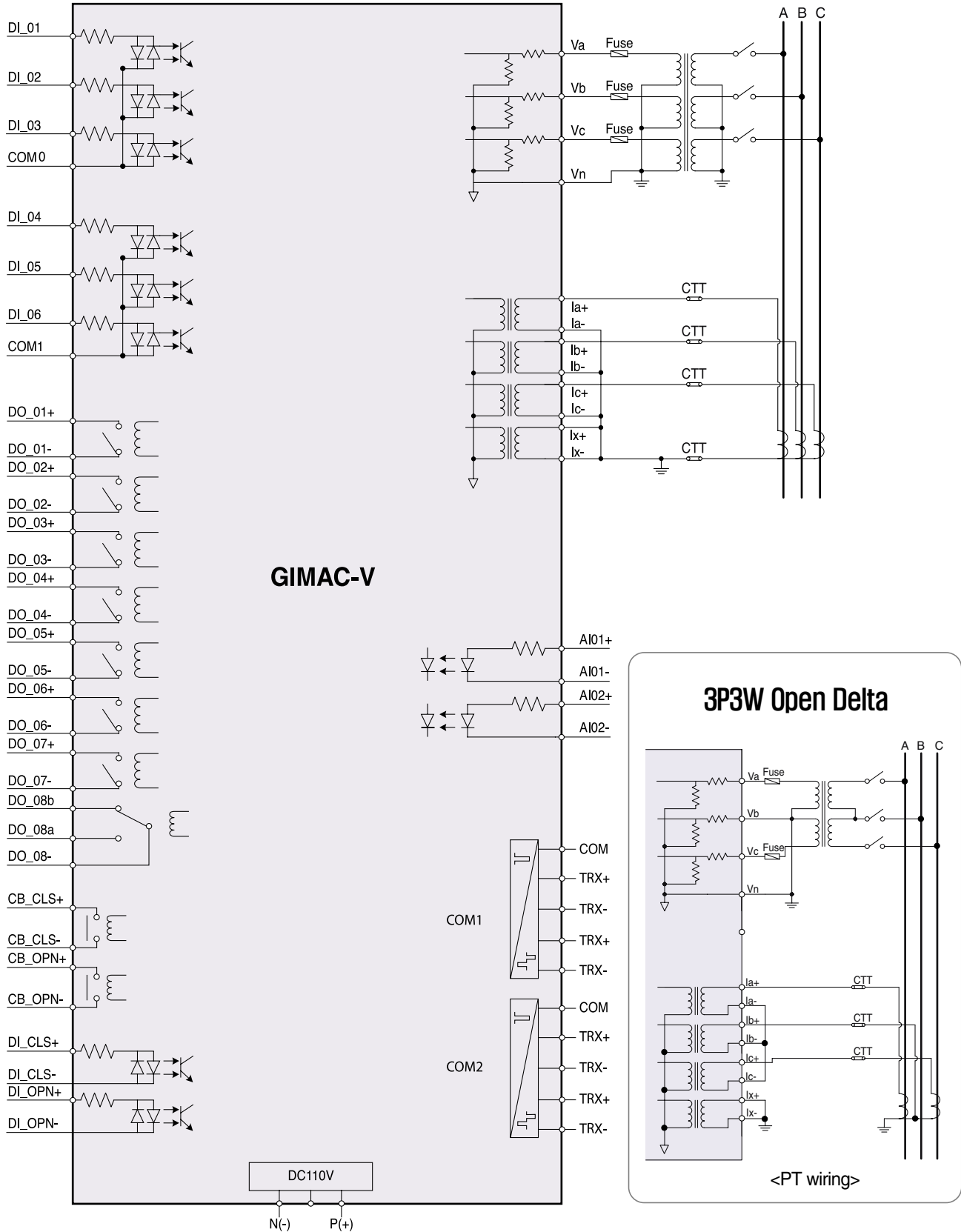

Wiring

3P4W

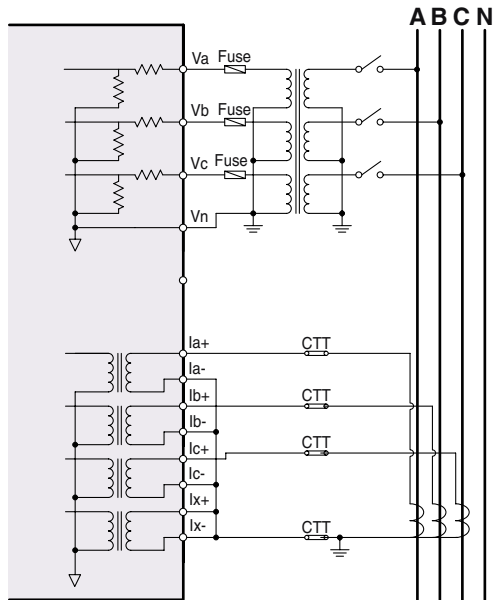

<Wiring incl. PT>

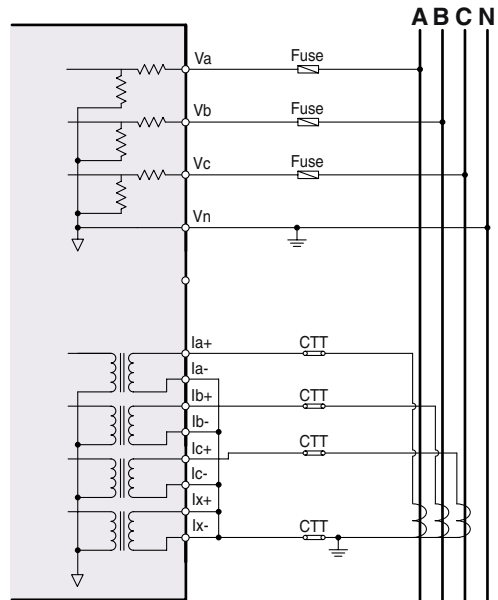

<Direct wiring>

1P3W

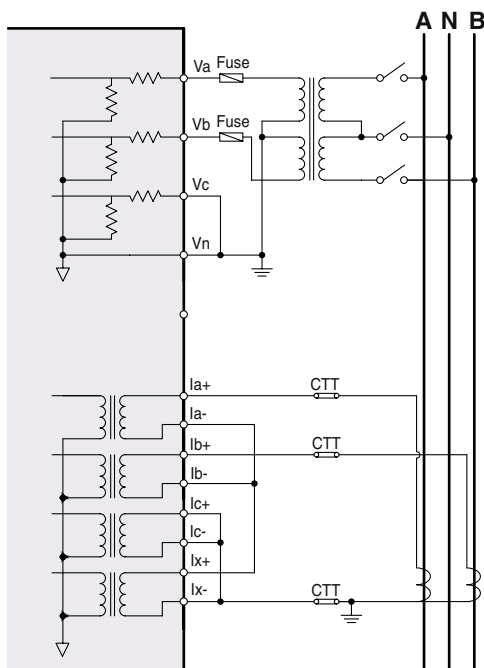

1P2W

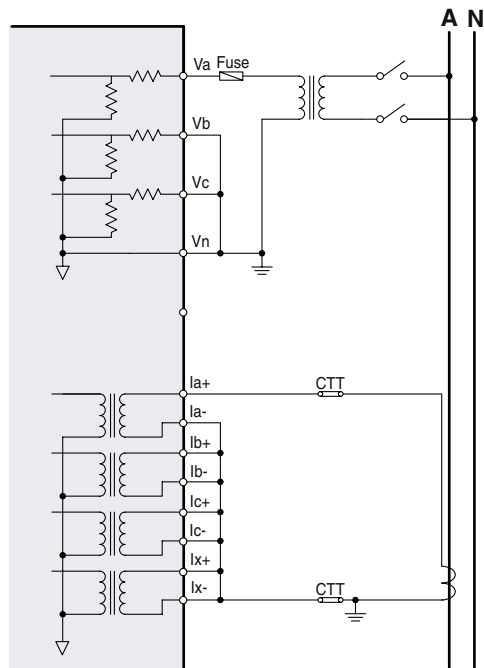

System configurations

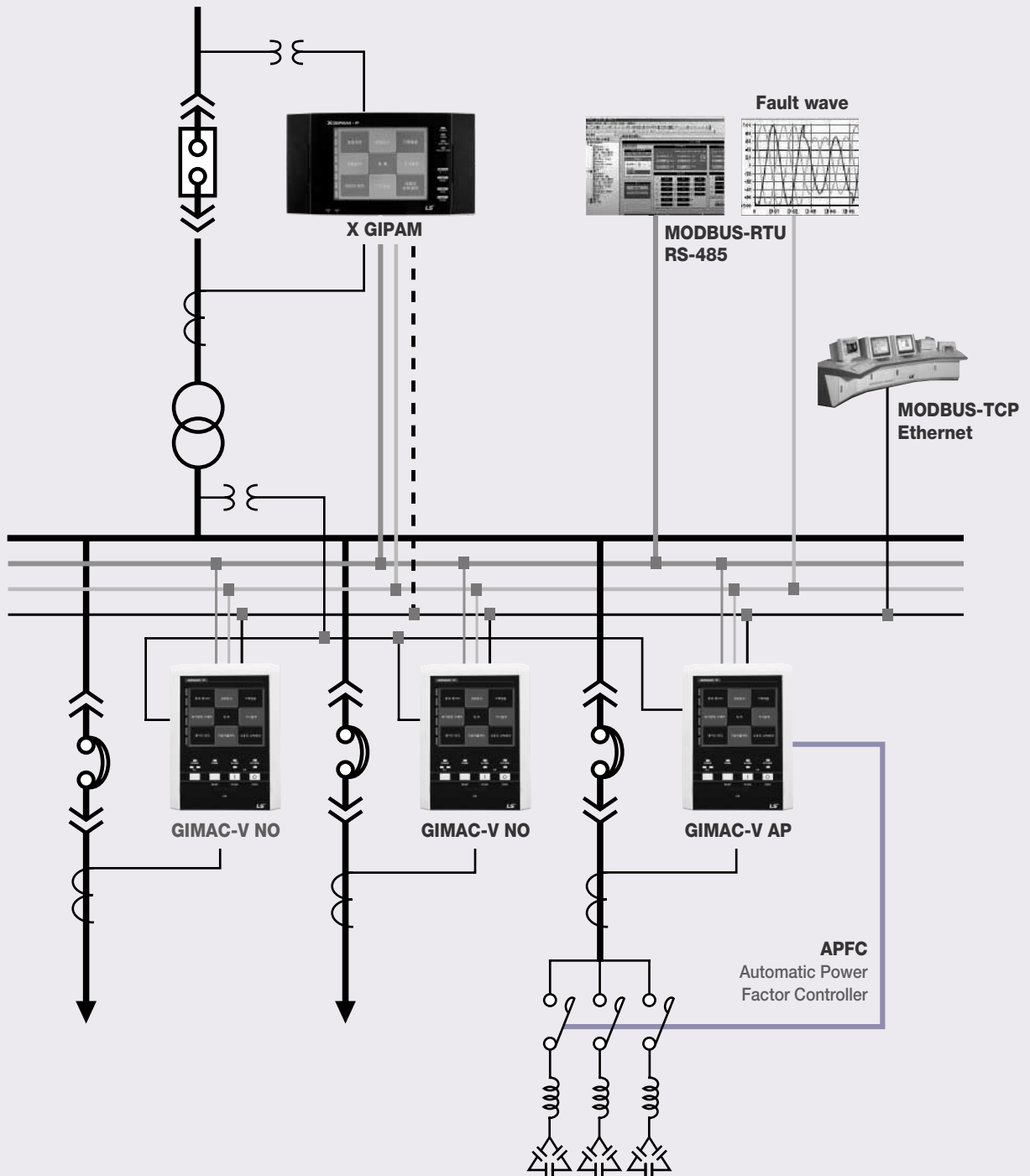

Digital Integrated Metering & Control Device/Power Quality Meter/Automatic Power Factor Controller

Dimensions and ordering

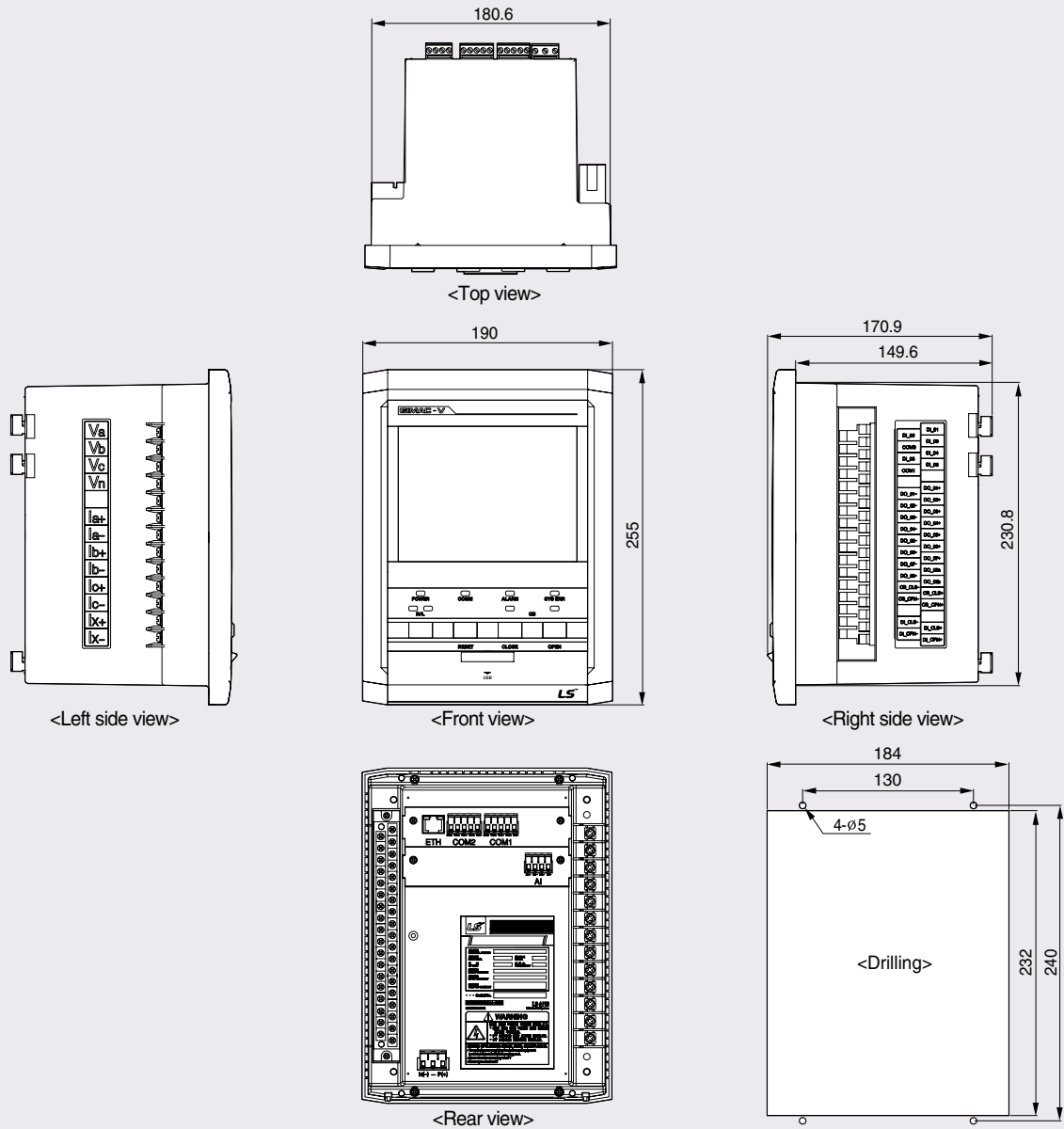

ordering

GIMAC - V

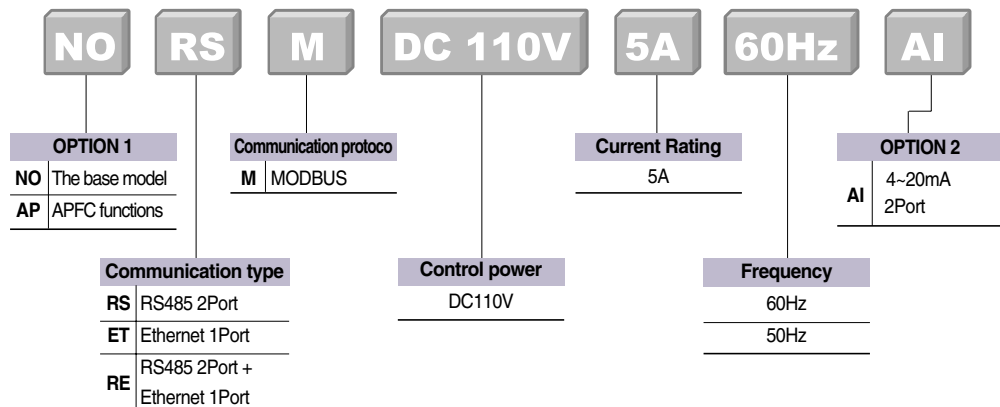

GIMAC-PQ



Power Quality Meter



IEC 1036, KEMC 1110



Various measurement functions
High accuracy (0.2%)



15th Harmonics & THD, TDD, k-Factor



Event recording : Max. 256EA



Fault wave recording : Max. 60cycle



Analog Input : DC 4~20mA



MODBUS/RS-485
Dual communication

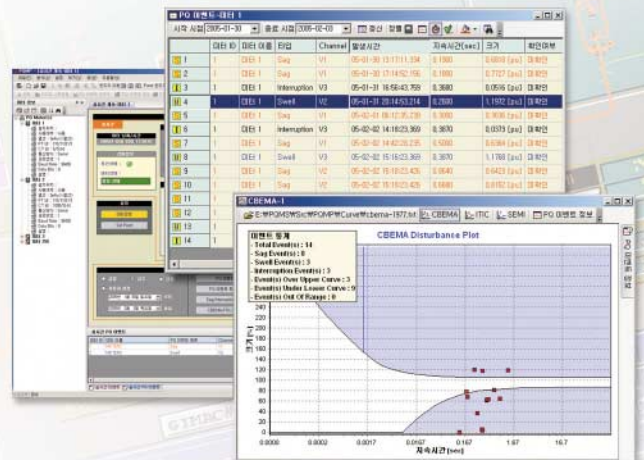



O₂



Contents :

Technical Specifications	O-2-4
External	O-2-6
MMI	O-2-7
Wirings	O-2-8
Dimension	O-2-10
Ordering	O-2-11



Power Quality Meter

Technical Specifications

Rating

Model		GIMAC-PQ	
Wirings		1P2W, 1P3W, 3P3W, 3P4W	
Input	Frequency	50Hz / 60Hz	
	Voltage	PT	10~230V
		GPT	2.2~230V
	Current	CT	0.05~6A
	Control voltage		AC/DC 110V
	Power consumption		Max. 30W
	Burden	PT	Max. 1.0VA
		CT	Max. 1.0VA
Input contact 10EA		Digital Input : AC/DC 110V	
Output contact	2EA for power	AC230V 16A / DC30V 16A, Resistive load 3680VA, 480W	
		AC230V 8A / DC30V 8A, Inductive load(cos ϕ =0.4, L/R=7ms) 1840VA, 240W	
	8EA for alarm	AC230V 12A / DC25V 12A, Resistive load 2760VA, 300W	
		AC230V 6A / DC25V 6A, Inductive load(cos ϕ =0.4, L/R=7ms) 1880VA, 150W	
Insulation Resistance		Over DC 500V 100M Ω	
Insulation Voltage		AC 2kV (1kV) / 1min	
Impulse Voltage		AC 5kV (3kV) / 1.2 \times 50 μ s	
Overload withstand	Current circuit	2 In for 3 hours 20 In for 2 seconds	
	Voltage circuit	1.15 Vn for 3 hours	
Fast Transient Disturbance		Power Input 4kV Other Input 2kV (Analog Input 1kV)	
ESD(Electrostatic Discharge)		Air 8kV Contact 6kV	
Operation temperature		-10°C ~ 55°C	
Storage temperature		-25°C ~ 70°C	
Humidity Average		30 ~ 80%	
Altitude		1000m and below	
Others		Non-impact place Non-air pollution place	
Standard		IEC 60255, IEC 61326, IEC 61000-4, KEMC 1110	
Communication		MODBUS/RS-485, I-NET	
Dimension(W \times H \times D)		190 \times 255 \times 116 (mm)	
Weight		3.6 kg	

Power quality functions

Power quality	Effective voltage	Fault type	Continuous time	Remarks
Sag	0.1~0.9pu	Instantaneous sag	0.5~30cycle	* Fault wave : Max. 60cycle * Event : Max. 256EA * Blinking alarm LED * Output Event DO
		Momentary sag	30cycle~3sec	
		Temporary sag	3sec~1min	
Swell	1.1~1.8pu	Instantaneous swell	0.5~30cycle	
		Momentary swell	30cycle~3sec	
		Temporary swell	3sec~1min	
Interruption	0.1pu and below	Momentary Interruption	0.5~3sec	
		Temporary Interruption	3sec~1min	
Undervoltage	0.8~0.9pu		over 1min	
Oversvoltage	1.1~1.2pu		over 1min	

Measurement functions

Model	Measurement	Display range	Accuracy	Remarks
GIMAC-PQ	Current, I	0.000A ~ 999.99kA	±0.2%	Ia, Ib, Ic, In
	Voltage, V	0.000V ~ 999.99kV	±0.2%	Va, Vb, Vc, Vab, Vbc, Vca
	Active power, Watts	0.000W ~ 99999.9MW	±0.5%	+ : Forward - : Reverse
	Reactive power, Var	0.000Var ~ 99999.9MVar	±0.5%	
	Apparent power, VA	0.000VA ~ 99999.9MVA	±0.5%	
	Active energy, Wh	0.000Wh ~ 99999.9MWh	±0.5%	
	Reactive energy, Varh	0.000Varh ~ 99999.9MVarh	±0.5%	
	Frequency, F	45 ~ 70Hz	±0.05Hz	
	Power factor, PF	-1.000 ~ 1.000	±0.5%	cos θ (+ : Lag, - : Lead)
	Phase	0.000° ~ 360.00°	±0.5°	
	Normal current, I ₁	0.000A ~ 999.99kA		
	Reverse phase current, I ₂	0.000A ~ 999.99kA		
	Zero phase voltage, V ₀	0.000V ~ 999.99kV	±0.5%	V ₀ , V _{0_max}
	Normal voltage, V ₁	0.000V ~ 999.99kV		
	Reverse phase voltage, V ₂	0.000V ~ 999.99kV		
	Unbalanced factor	0.000 ~ 100.00%		
	Harmonics I	0.000A ~ 999.99kA		2 nd ~ 15 th
	Harmonics V	0.000V ~ 999.99kV		2 nd ~ 15 th
	THD(V, I), TDD(I)			
	k-Factor			
	Demand I	0.000A ~ 999.99kA		Peak demand
	Demand W	0.000W ~ 99999.9MW		Peak demand
	AI (Analog Input)	4.000 ~ 20.00mA	±0.5%	

Power Quality Meter

External

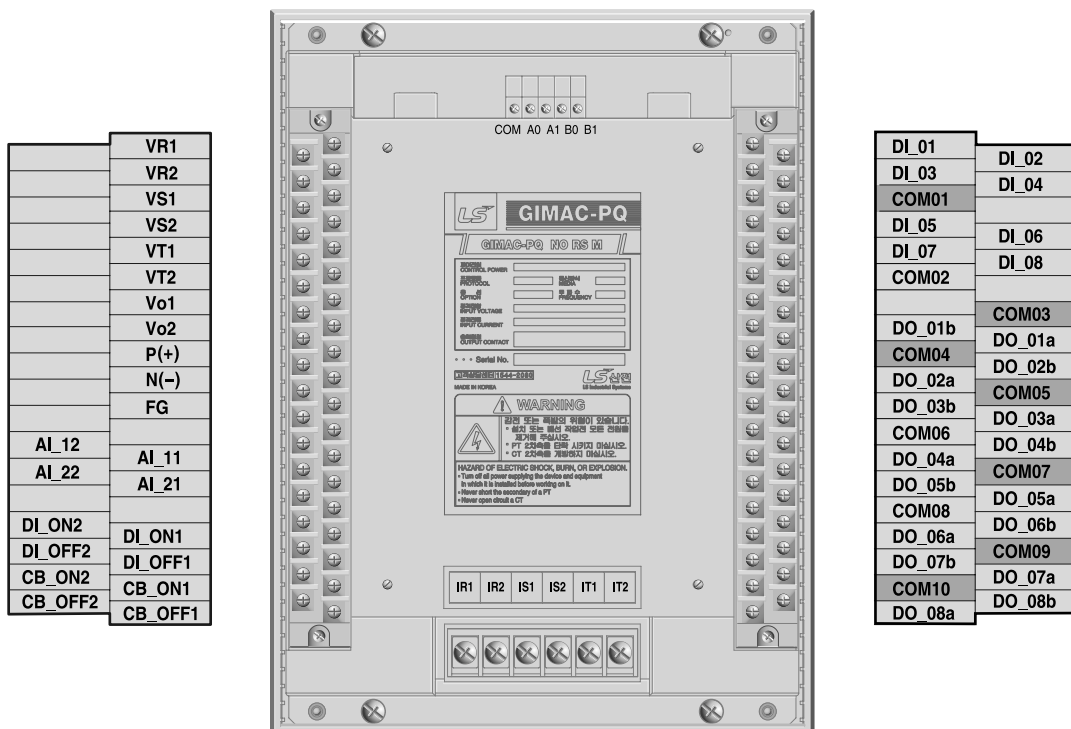
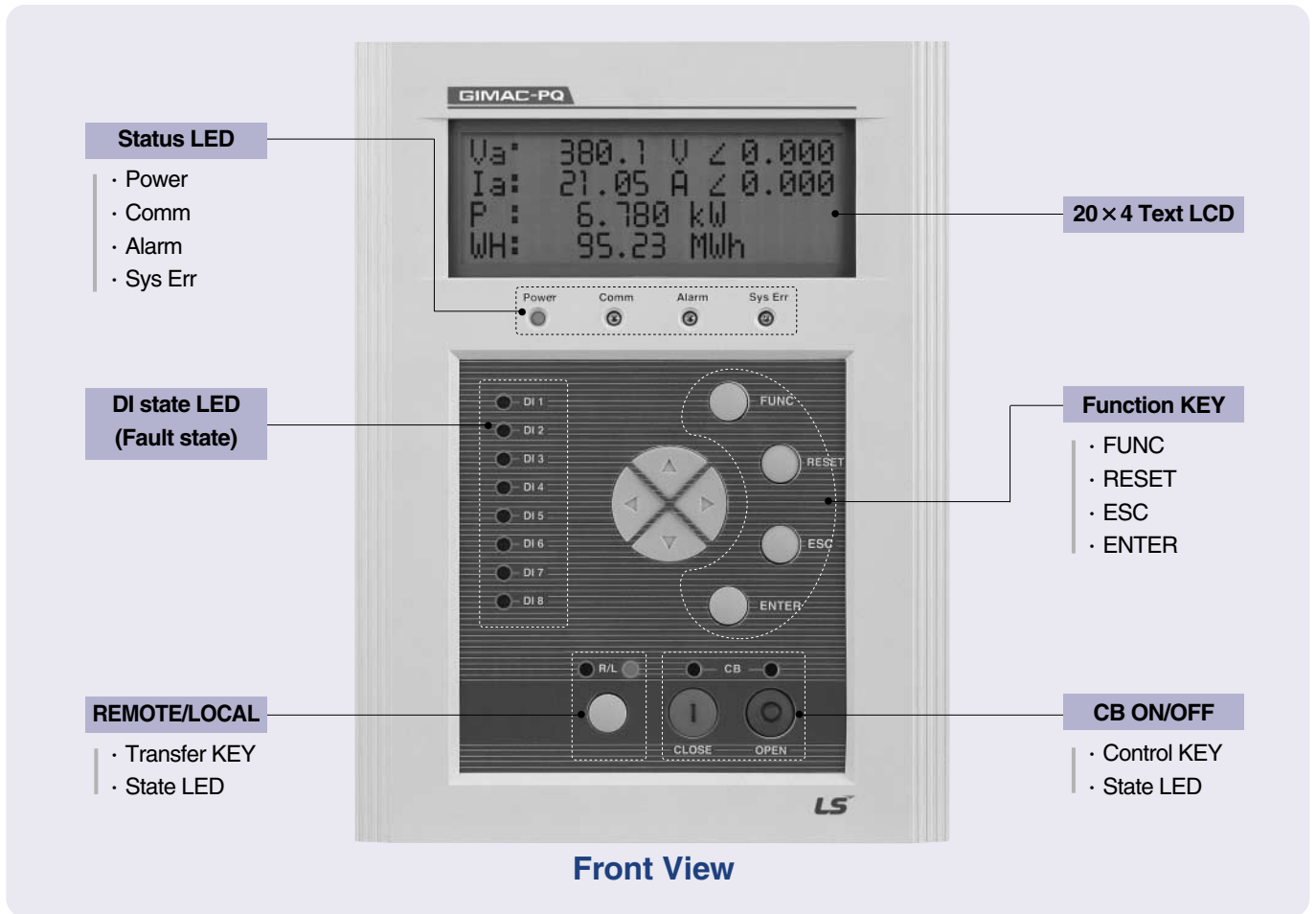

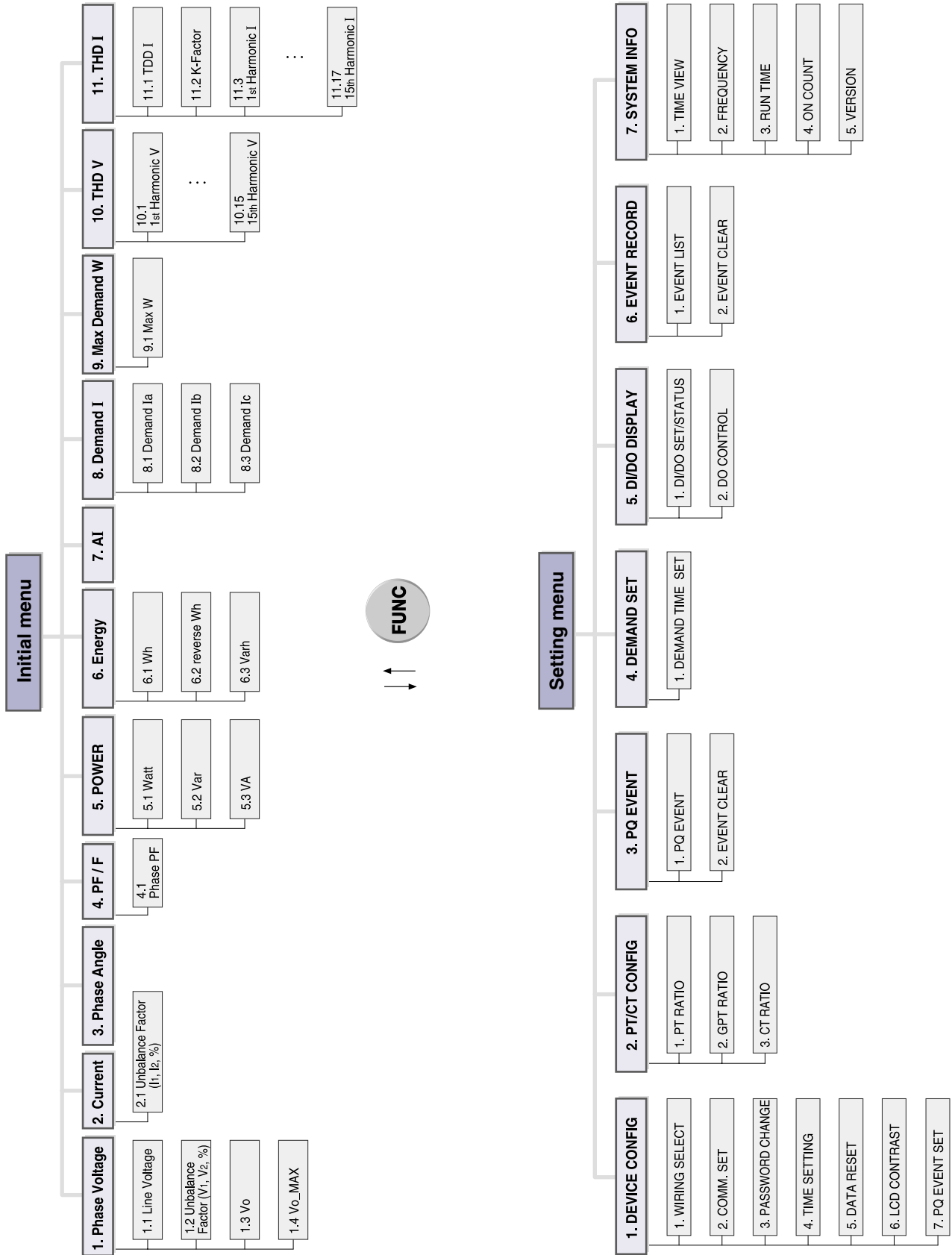

Power Quality Meter

Wirings

3P3W

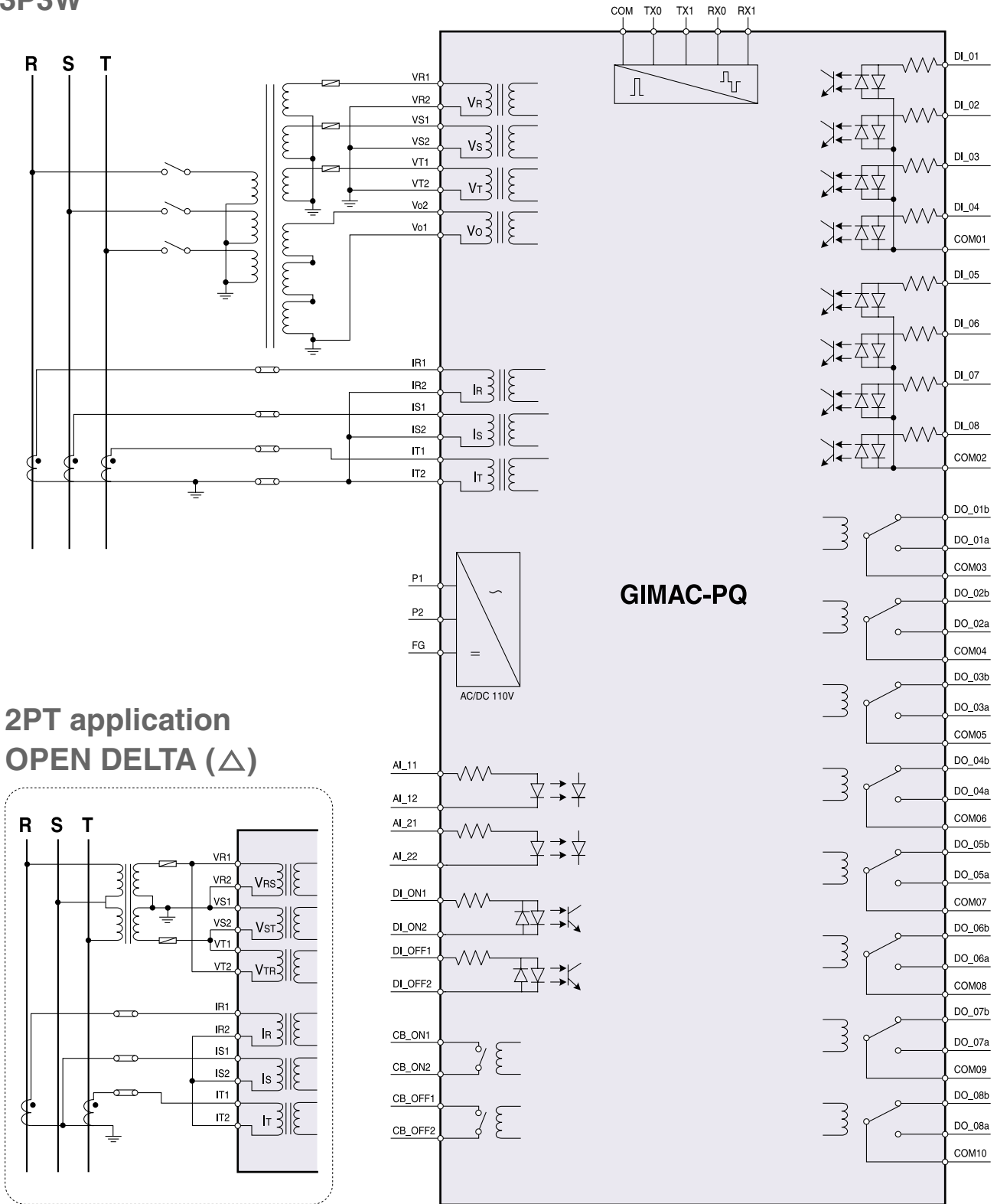

2PT application OPEN DELTA (Δ)

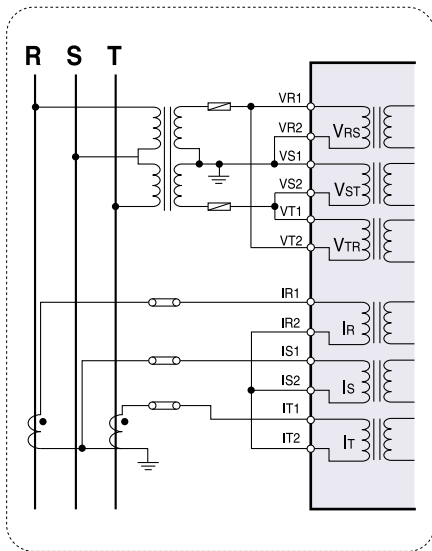

3P4W

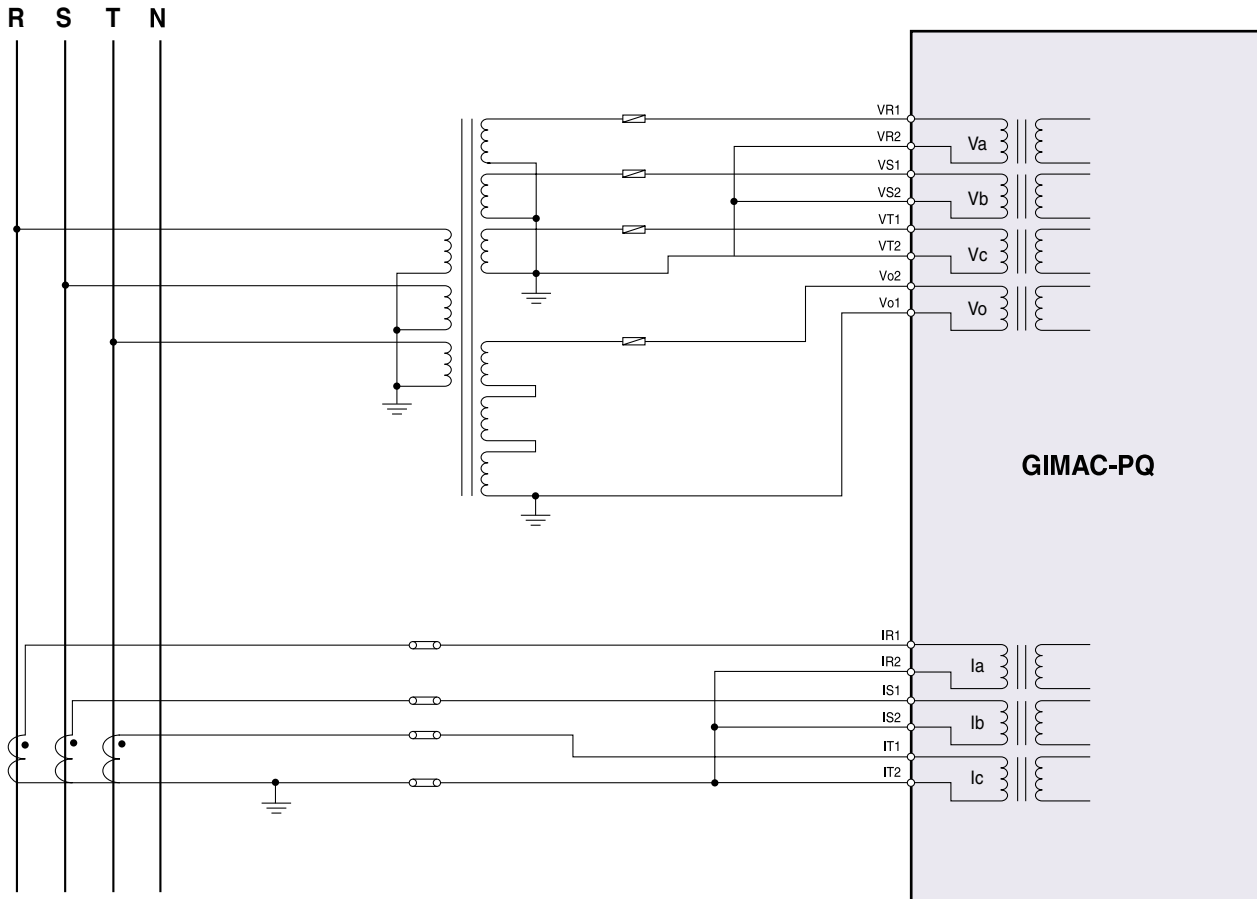

1P3W

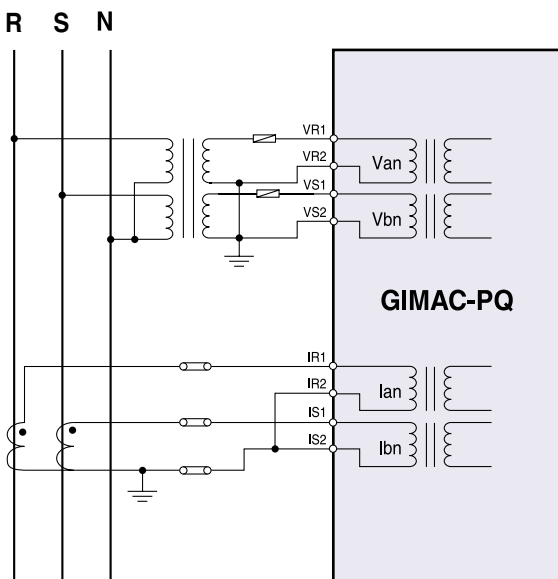

1P2W

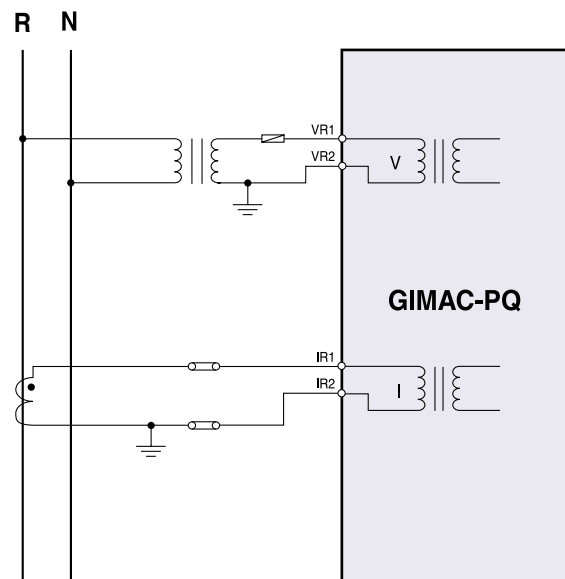

Power Quality Meter

Dimension

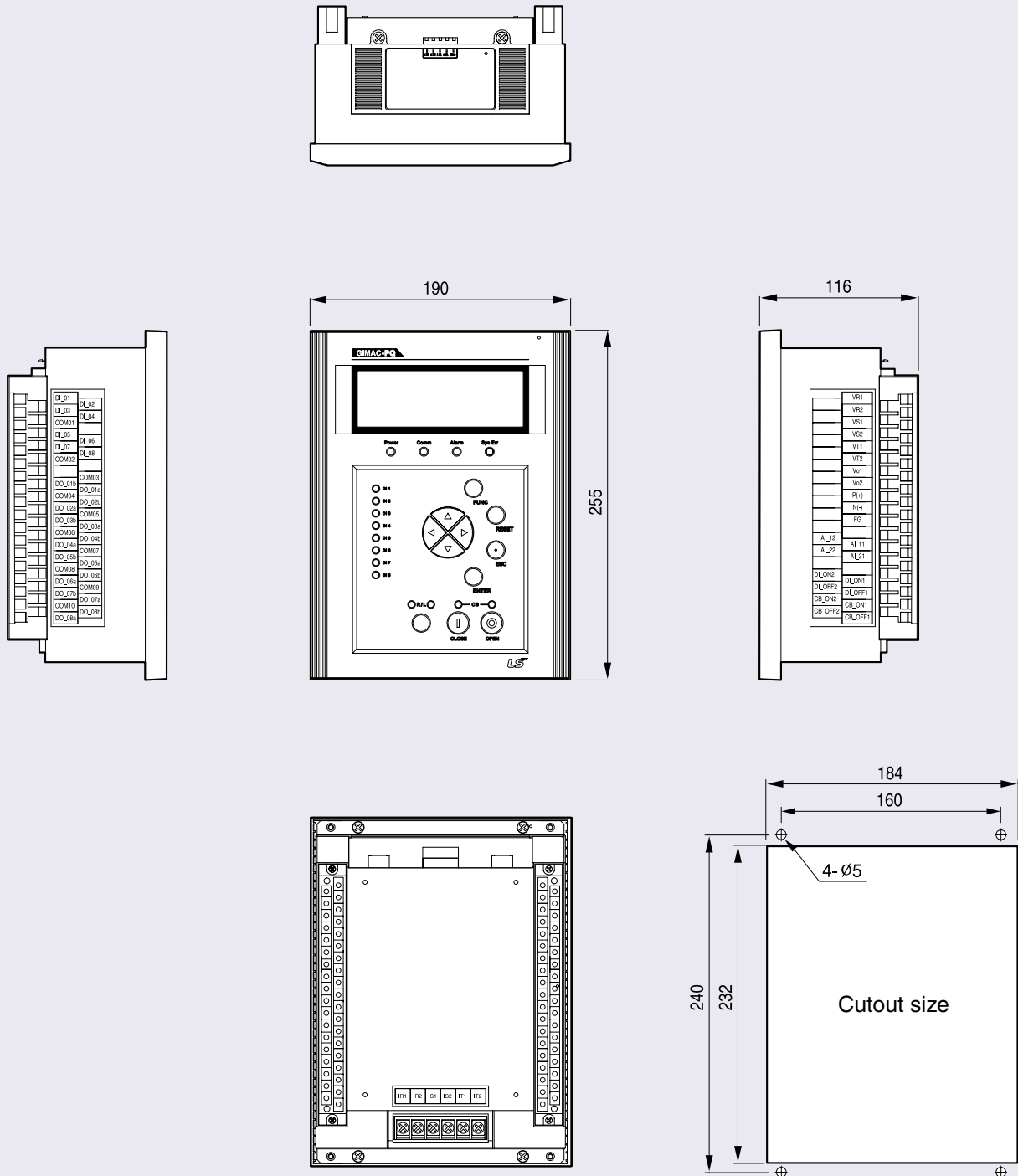

Ordering

GIMAC-PQ

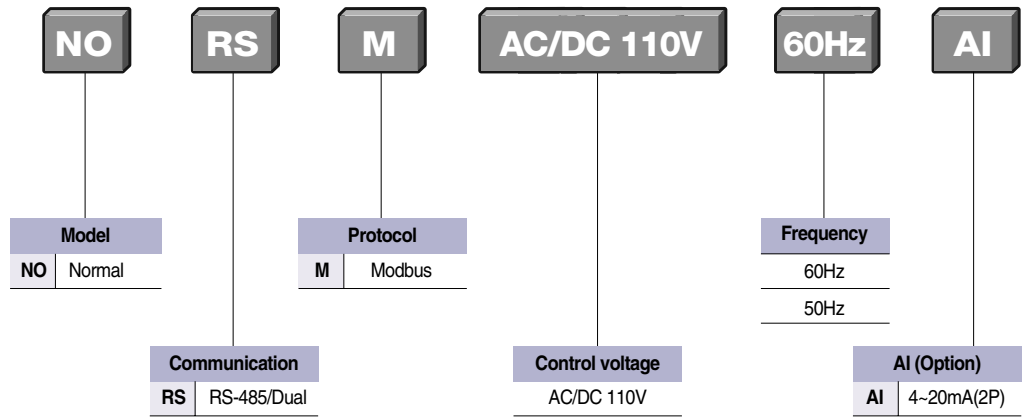

Power Quality Meter

GIMAC-PQ



GIMAC-IV



Digital Integrated Metering & Control Device



IEC 1036, KEMC 1110



Various measurement functions
High accuracy (0.2%)

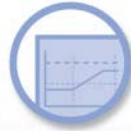

Automatic power factor
controller (option)



63th Harmonics & THD



Demand controller (option)



Event recording : Max. 300EA



Analog Input : DC 4~20mA



MODBUS/RS-485, DNP3.0/RS-485, I-NET

O₃



Contents :

Technical Specifications	0-3-4
Functional Block Diagram	0-3-7
External	0-3-8
MMI	0-3-9
Wirings	0-3-10
Dimension	0-3-12
Ordering	0-3-13



**GIMAC-IV /
APFC / DC**



Digital Integrated Metering & Control Device

Technical Specifications

Rating

Model		GIMAC-415	
Wirings		1P2W, 1P3W, 3P3W, 3P4W	
Input	Frequency	50Hz / 60Hz	
	Voltage	PT	10~230V
		GPT	2.2~230V
	Current	CT	0.05~6A
	Control voltage		AC/DC 110V
	Power consumption		Max. 30W
	Burden	PT	Max. 1.0VA
		CT	Max. 1.0VA
	Input contact 10EA		Digital Input : AC/DC 110V
Output contact	2EA for power	AC230V 16A / DC30V 16A, Resistive load 3680VA, 480W	
		AC230V 8A / DC30V 8A, Inductive load(cos ϕ =0.4, L/R=7ms) 1840VA, 240W	
	8EA for alarm	AC230V 12A / DC25V 12A, Resistive load 2760VA, 300W	
		AC230V 6A / DC25V 6A, Inductive load(cos ϕ =0.4, L/R=7ms) 1880VA, 150W	
Insulation Resistance		Over DC 500V 100M Ω	
Insulation Voltage		AC 2kV (1kV) / 1min	
Impulse Voltage		AC 5kV (3kV) / 1.2 \times 50 μ s	
Overload withstand	Current circuit	2 In for 3 hours 20 In for 2 seconds	
	Voltage circuit	1.15 Vn for 3 hours	
Fast Transient Disturbance		Power Input 4kV Other Input 2kV (Analog Input 1kV)	
ESD(Electrostatic Discharge)		Air 8kV Contact 6kV	
Operation temperature		-10°C ~ 55°C	
Storage temperature		-25°C ~ 70°C	
Humidity Average		30 ~ 80%	
Altitude		1000m and below	
Others		Non-impact place Non-air pollution place	
Standard		IEC 60255, IEC 61326, IEC61000-4, KEMC 1110	
Communication		MODBUS/RS-485, I-NET	
Dimension(W \times H \times D)		190 \times 255 \times 116 (mm)	
Weight		3.6 kg	

Measurement functions

Model	Measurement	Display range	Accuracy	Remarks
GIMAC-415	Current, I	0.000A ~ 999.99kA	±0.2%	Ia, Ib, Ic, In
	Voltage, V	0.000V ~ 999.99kV	±0.2%	Va, Vb, Vc, Vab, Vbc, Vca
	Active power, Watts	0.000W ~ 99999.9MW	±0.5%	+ : Forward - : Reverse
	Reactive power, Var	0.000Var ~ 99999.9MVar	±0.5%	
	Apparent power, VA	0.000VA ~ 99999.9MVA	±0.5%	
	Active energy, Wh	0.000Wh ~ 99999.9MWh	±0.5%	
	Reactive energy, Varh	0.000Varh ~ 99999.9MVarh	±0.5%	
	Frequency, F	45 ~ 70Hz	±0.05Hz	
	Power factor, PF	-1.000 ~ 1.000	±0.5%	cos ϕ (+ : Lag, - : Lead)
	Phase	0.000° ~ 360.00°	±0.5°	
	Normal current, I ₁	0.000A ~ 999.99kA		
	Reverse phase current, I ₂	0.000A ~ 999.99kA		
	Zero phase voltage, V ₀	0.000V ~ 999.99kV	±0.5%	V ₀ , V _{0_max}
	Normal voltage, V ₁	0.000V ~ 999.99kV		
	Reverse phase voltage, V ₂	0.000V ~ 999.99kV		
	Unbalanced factor	0.000 ~ 100.00%		
	Harmonics I	0.000A ~ 999.99kA		2 nd ~63 th
	Harmonics V	0.000V ~ 999.99kV		2 nd ~63 th
	Demand I	0.000A ~ 999.99kA		Peak demand
	Demand W	0.000W ~ 99999.9MW		Peak demand
AI (Analog Input)	4.000 ~ 20.00mA	±0.5%		

Communication

Type	Item	Specifications	Remarks
I-NET	Baud rate	250kbps	LS custom protocol
	Distance	Max. 1km	
	Cable spec	Low Capacitance LAN Interface cable LIREV-AMESB 22AWG 2-Pair(7/0.254TA)	
	Insulation	Pulse Transformer	
	Impedance	10MHz, 120 Ω	
	Wiring	4-Wire Multi-drop	
	Termination	120 Ω (2EA)	
	Modulation	Bipolar	
MODBUS/RS-485	Operation mode	Differential	
	Baud rate	9600, 19200, 38400bps	
	Distance	Max. 1.2km	
	Cable spec	Standard RS-485 Shielded Twist 2-Pair cable	
	Transmission	Half-Duplex	
	Max. input/output	-7V ~ +12V	

Digital Integrated Metering & Control Device

Technical Specifications

APFC (Automatic power factor controller)

Model		GIMAC-415 AP
BANK setting	BANK number	0 ~ 8EA
	Alarm number	0 ~ 1EA
BANK control contact	1BANK 1a	DO_01a ~ DO_08a (Latch)
	1BANK 1b	DO_01b ~ DO_08b (Latch)
	1BANK 2a	DO_01a ~ DO_08a (ON / OFF separate, 500ms Pulse)
Capacitor setting		None ~ 9,999MVA (Auto/Manual)
Alarm contact		DO_01-08(1EA)
Capacitor closing delay time		3 ~ 300 sec / 1sec
Dead time		3 ~ 300 sec / 1sec
Max. value setting		0.90 ~ 1 ~ -0.90 (- : Lead)
Min. value setting		0.50 ~ 0.90
Alarm value setting		0.00 ~ 0.90
Event recording (Alarm)		Reverse Current
		Low Current
		Under Voltage
		Over Switching
		Over PF
Power factor control sequence		Under PF
		Auto control
		Manual control
		Complex control
		Cyclic control

Demand Controller

Model		GIMAC-415 DC
Monitoring		Target power Wt, Estimate power We(t), Standard power Wt(t), Current power Wc(t)
		Load control state
		Event
		DC time and state display
Load setting	Load number	0 ~ 8EA
	Alarm number	0 ~ 2EA
Load control contact	1LOAD 1a	DO_01a ~ DO_08a (Latch)
	1LOAD 1b	DO_01b ~ DO_08b (Latch)
	1LOAD 2a	DO_01a ~ DO_08a (ON / OFF separate, 500ms Pulse)
Alarm contact	Alarm 1	Estimate power > Target power
	Alarm 2	Current power > Standard power
Demand time		5 ~ 60min / 5min
Start time		0 ~ Demand time / 1min
Period time		10 ~ 60sec / 1sec
Delay time		1 ~ (Period time-1)sec / 1sec
Target active power(Wt)		100W ~ 99,999MW
Alarm		1 st , 2 nd alarm
Demand control sequence		Auto control
		Manual control
		Priority control

Functional Block Diagram

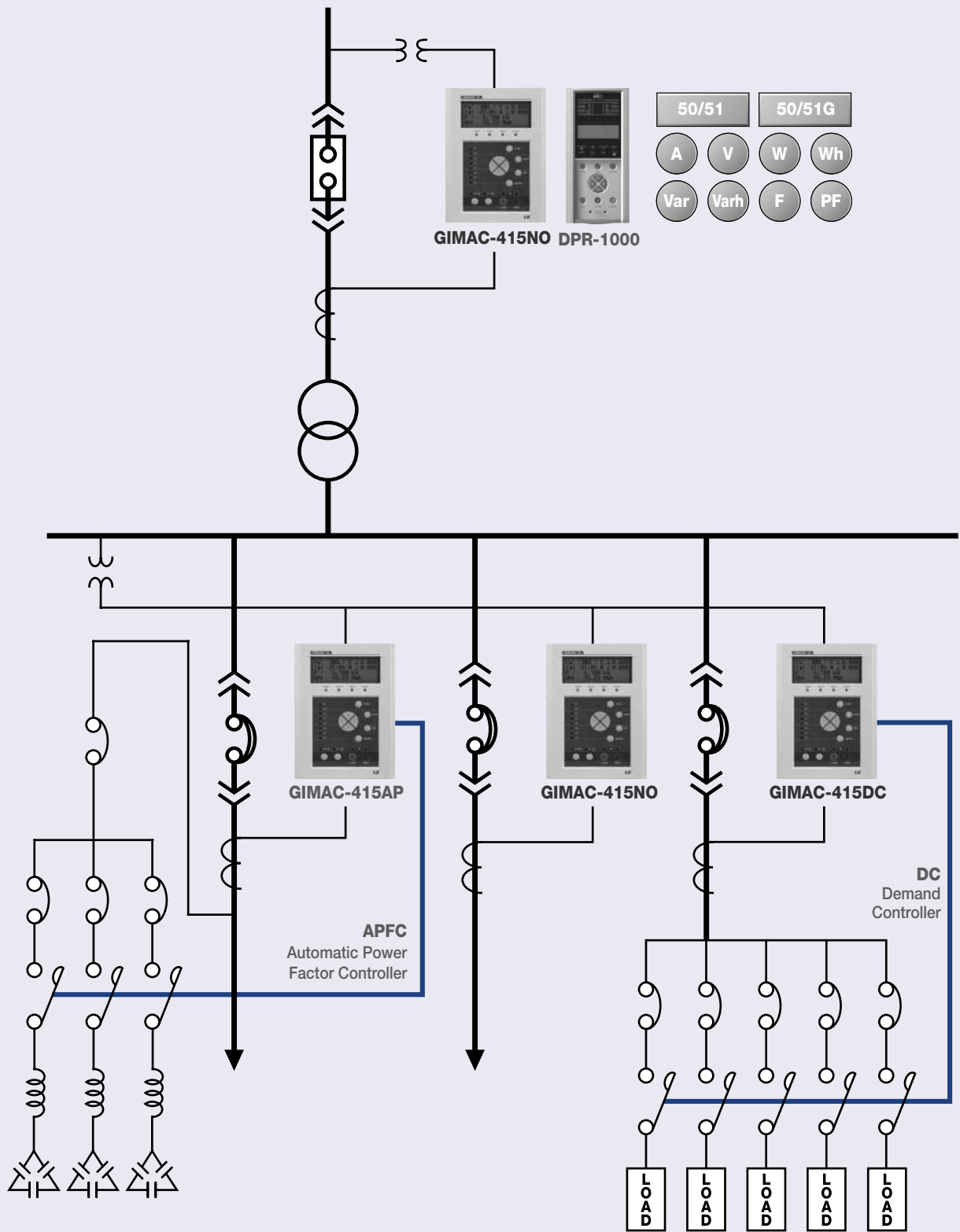

Digital Integrated Metering & Control Device

External

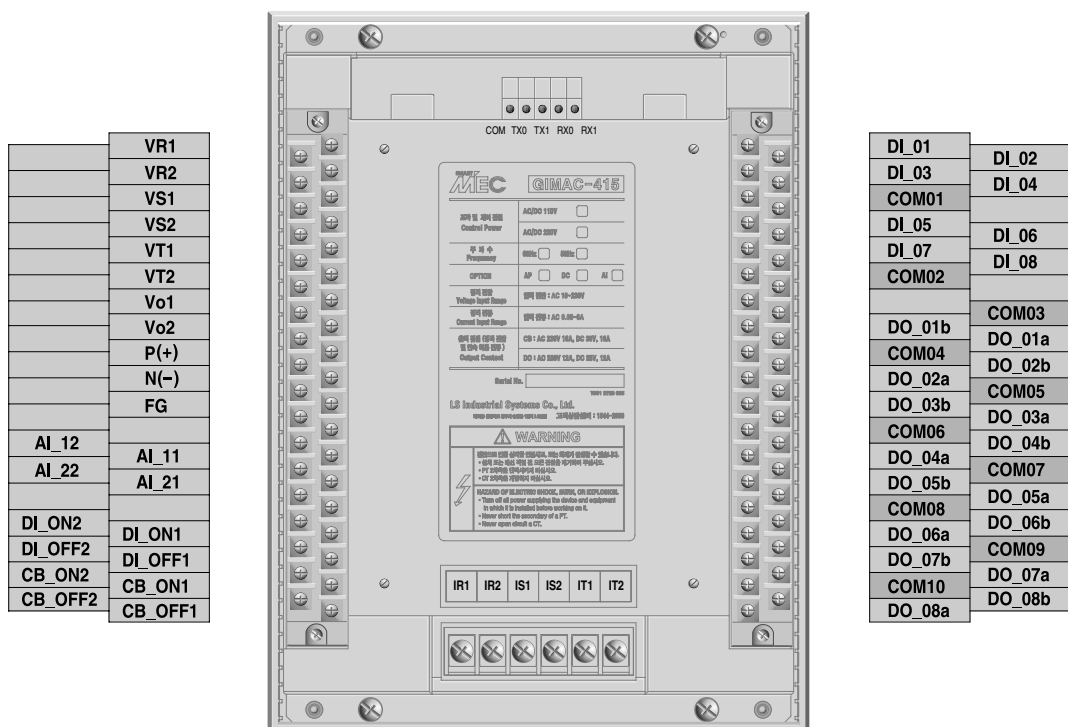
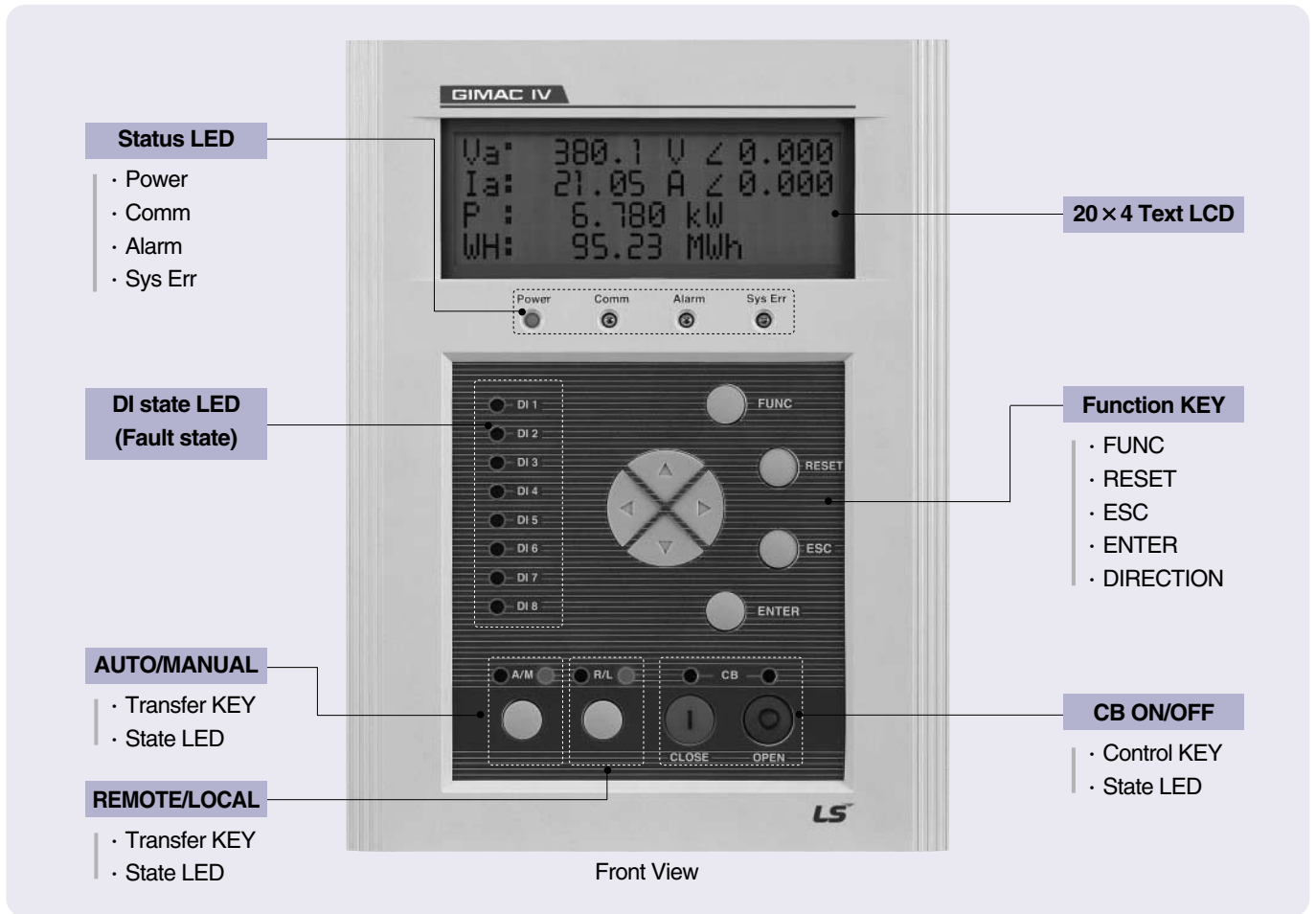



Digital Integrated Metering & Control Device

Wirings

3P3W

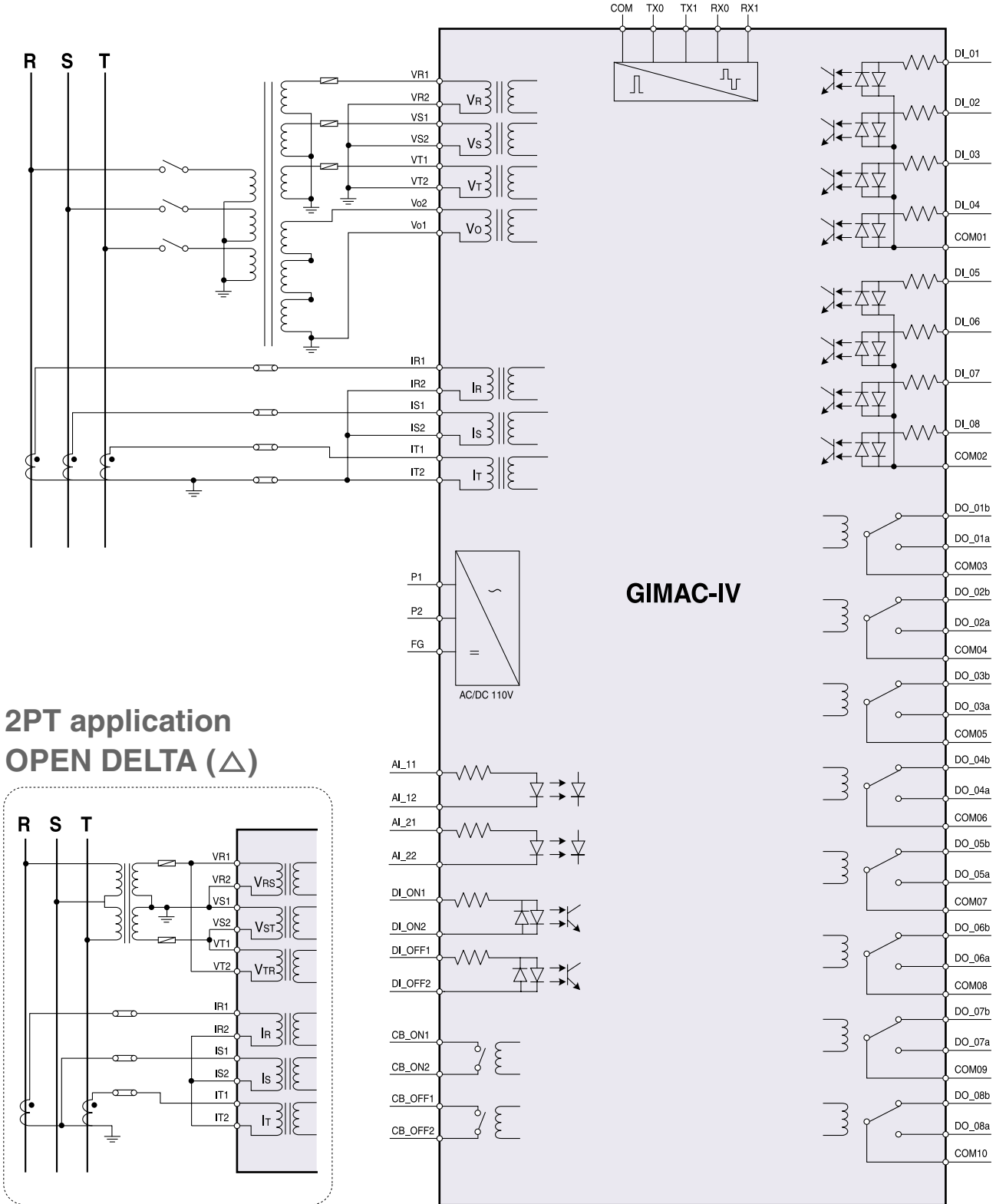

Ordering

GIMAC-415

NO

Model	
NO	Normal
AP	APFC
DC	Demand Control
PD	APFC, D/C

RS

Communication	
RS	RS-485
IN	I-NET

M

Protocol	
M	Modbus
I	I-NET
D	DNP3.0

AC/DC 110V

Control voltage
AC/DC 110V

60Hz

Frequency
60Hz
50Hz

AI

AI (Option)	
AI	4~20mA(2P)

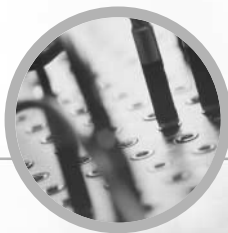

Digital Integrated Metering & Control Device

Automatic Power Factor Controller

Demand Controller

GIMAC-II *plus*

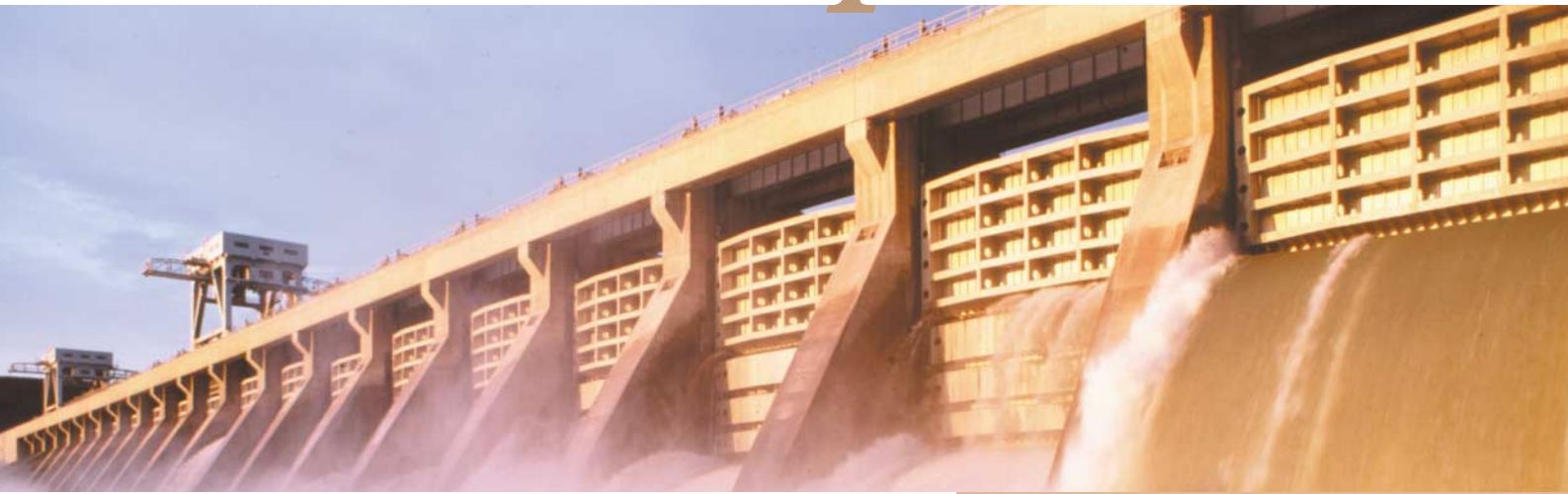

Digital Integrated Metering &
Control Device



IEC 60255, KEMC 1110
ISO 9001, ISO 14001



Various measurement functions
High accuracy (0.3%)



Event recording : Max. 256EA



MODBUS/RS-485, I-NET



Select before operation



Self-diagnosis





Contents :

Technical specifications	O-4-4
External	O-4-6
Wirings	O-4-7
Dimension & Ordering	O-4-9



Digital Integrated Metering & Control Device

Technical specifications

Rating

Model		GIMAC-115	
Wirings		1P2W, 1P3W, 3P3W, 3P4W	
Input	Frequency	50Hz / 60Hz	
	Voltage	PT	10~230V
		GPT	2.2~230V
	Current	CT	0.05~6A
	Control voltage		AC/DC 110V
	Power consumption		Max. 30W
	Burden	PT	Max. 1.0VA
		CT	Max. 1.0VA
Input contact 10EA		Digital Input : AC/DC 110V	
Output contact	2EA for power	AC230V 16A / DC30V 16A, Resistive load 3680VA, 480W	
		AC230V 8A / DC30V 8A, Inductive load($\cos \phi = 0.4$, L/R=7ms) 1840VA, 240W	
	8EA for alarm	AC230V 12A / DC25V 12A, Resistive load 2760VA, 300W	
		AC230V 6A / DC25V 6A, Inductive load($\cos \phi = 0.4$, L/R=7ms) 1880VA, 150W	
Insulation Resistance Over		DC 500V 100M Ω	
Insulation Voltage		AC 2kV (1kV) / 1min	
Impulse Voltage		AC 5kV (3kV) / $1.2 \times 50 \mu s$	
Overload withstand	Current circuit	2 In for 3 hours 20 In for 2 seconds	
	Voltage circuit	1.15 Vn for 3 hours	
Fast Transient Disturbance		Power Input 4kV Other Input 2kV (Analog Input 1kV)	
ESD(Electrostatic Discharge)		Air 8kV Contact 6kV	
Operation temperature		-10°C ~ 55°C	
Storage temperature		-25°C ~ 70°C	
Humidity Average		30 ~ 80%	
Altitude		1000m and below	
Others		Non-impact place Non-air pollution place	
Standard		IEC 60255, IEC 61326, IEC 61000-4, KEMC 1110	
Communication		MODBUS/RS-485, I-NET	
Dimension(W × H × D)		190 × 255 × 116 (mm)	
Weight		3.6 kg	

Measurement functions

Model	Measurement	Display range	Accuracy	Remarks
GIMAC-115	Current, I	0.000A ~ 999.99kA	±0.3%	Ia, Ib, Ic, In
	Voltage, V	0.000V ~ 999.99kV	±0.3%	Va, Vb, Vc, Vab, Vbc, Vca
	Active power, Watts	0.000W ~ 99999.9MW	±0.5%	+ : Forward - : Reverse
	Reactive power, Var	0.000Var ~ 99999.9MVar	±0.5%	
	Apparent power, VA	0.000VA ~ 99999.9MVA	±0.5%	
	Active energy, Wh	0.000Wh ~ 99999.9MWh	±0.5%	
	Reactive energy, Varh	0.000Varh ~ 99999.9MVarh	±0.5%	
	Frequency, F	45 ~ 70Hz	±0.05Hz	
	Power factor, PF	-1.000 ~ 1.000	±0.5%	cos θ (+ : Lag, - : Lead)
	Phase	0.000° ~ 360.00°	±0.5°	
	Normal current, I ₁	0.000A ~ 999.99kA		
	Reverse phase current, I ₂	0.000A ~ 999.99kA		
	Zero phase voltage, V ₀	0.000V ~ 999.99kV	±0.5%	V ₀ , V _{0_max}
	Normal voltage, V ₁	0.000V ~ 999.99kV		
	Reverse phase voltage, V ₂	0.000V ~ 999.99kV		
	Unbalanced factor	0.000 ~ 100.00%		
	Harmonics I	0.000A ~ 999.99kA		2 nd ~ 15 th
	Harmonics V	0.000V ~ 999.99kV		2 nd ~ 15 th
	THD (V, I)			
	TDD (I)			
	k-Factor			
	Demand I	0.000A ~ 999.99kA		Peak demand
	Demand W	0.000W ~ 99999.9MW		Peak demand
AI (Analog Input)	4.000 ~ 20.00mA	±0.5%		

Communication

Type	Item	Specifications	Remarks
I-NET	Baud rate	250kbps	LS custom protocol
	Distance	Max. 1km	
	Cable spec	Low Capacitance LAN Interface cable LIREV-AMESB 22AWG 2-Pair(7/0.254TA)	
	Insulation	Pulse Transformer	
	Impedance	10MHz, 120 Ω	
	Wiring	4-Wire Multi-drop	
	Termination	120 Ω (2EA)	
	Modulation	Bipolar	
MODBUS/RS-485	Operation mode	Differential	
	Baud rate	9600, 19200, 38400bps	
	Distance	Max. 1.2km	
	Cable spec	Standard RS-485 Shielded Twist 2-Pair cable	
	Transmission	Half-Duplex	
	Max. input/output	-7V ~ +12V	

Fault indication

Digital input	LED indicator					
	Normal	Fault input	Troubleshooting after reset		Reset after troubleshooting	
			Troubleshooting	Reset	Reset	Troubleshooting
Fault DI_1-8	Off	Blink	Blink	Off	On	Off

Digital Integrated Metering & Control Device

External

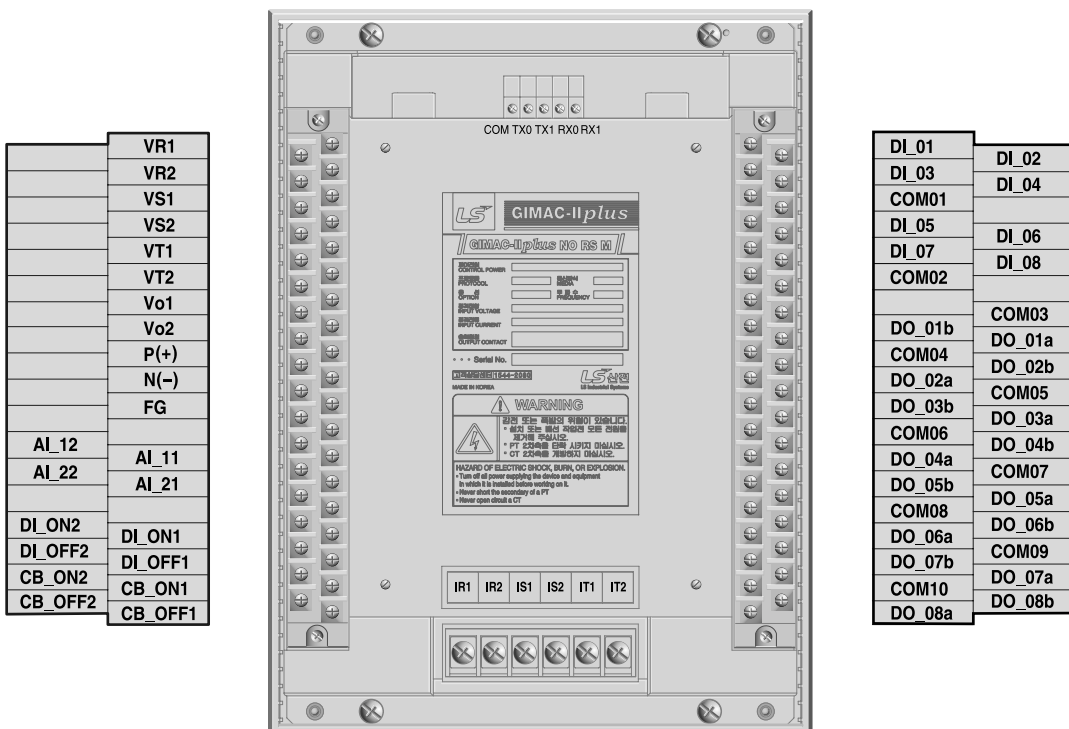
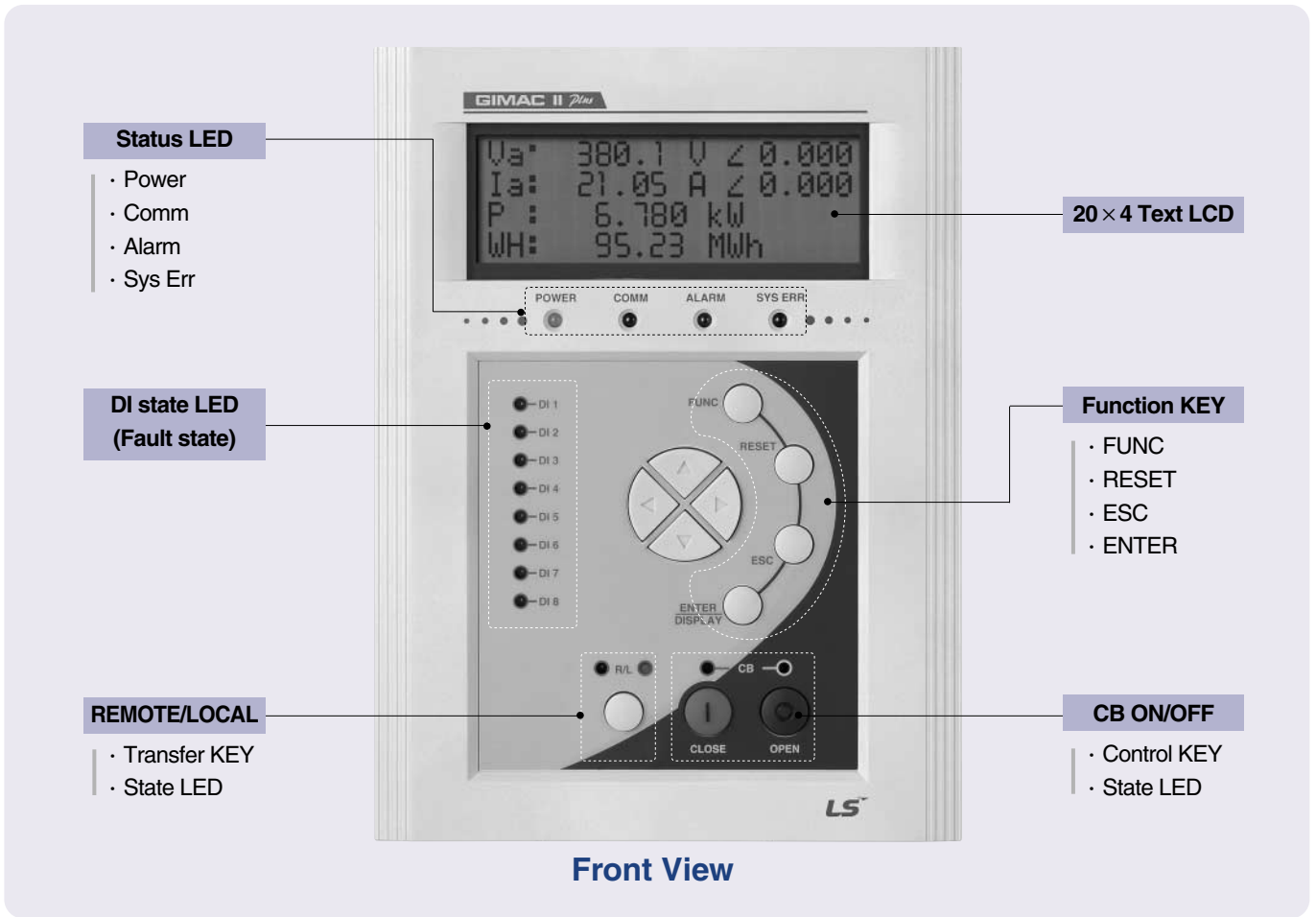

Wirings

3P3W

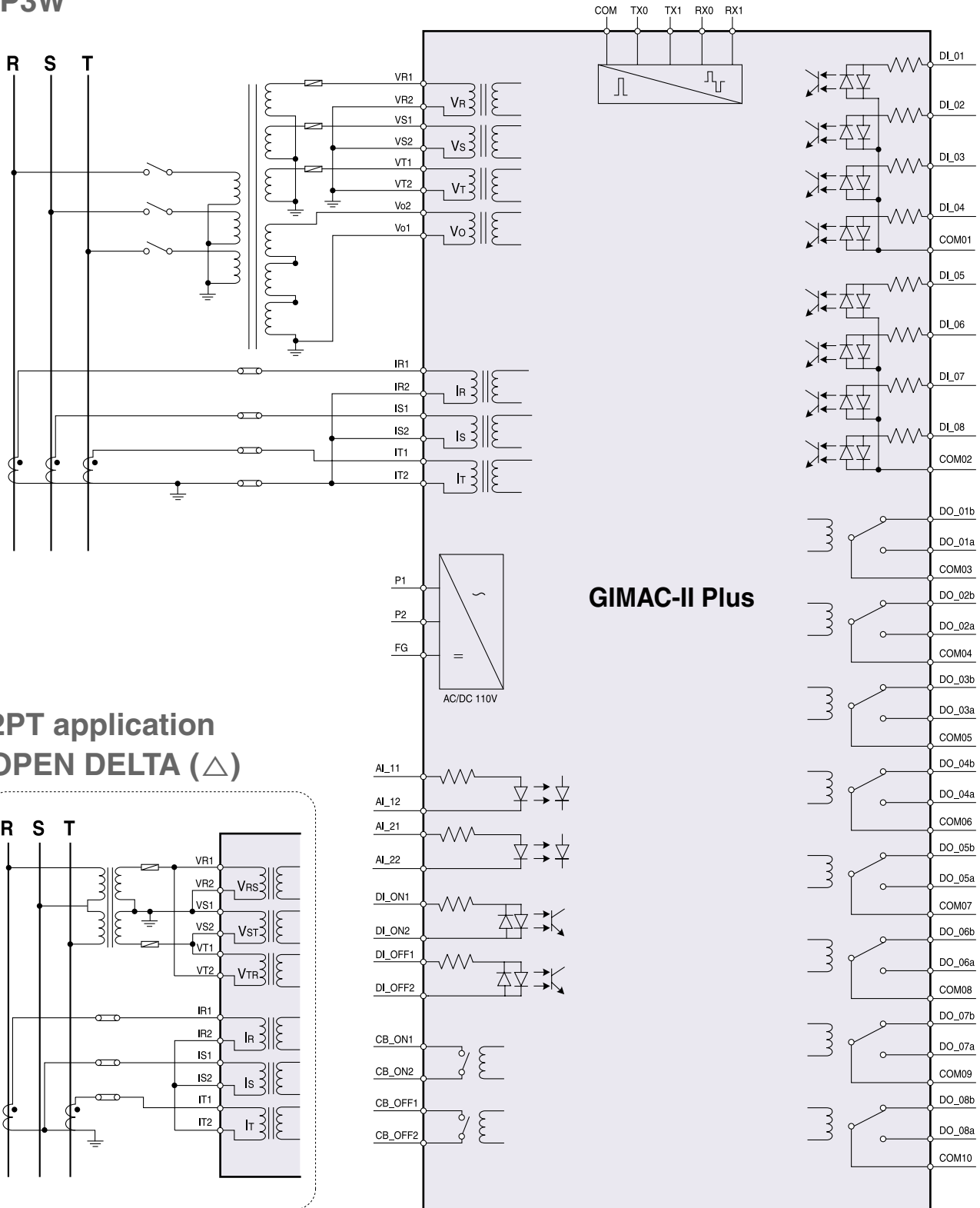

2PT application OPEN DELTA (Δ)

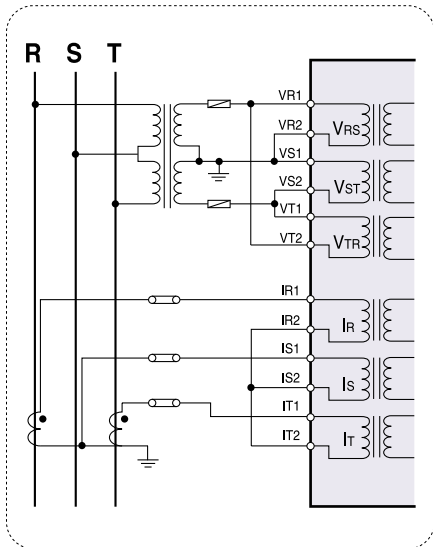

Digital Integrated Metering & Control Device

Wirings

3P4W

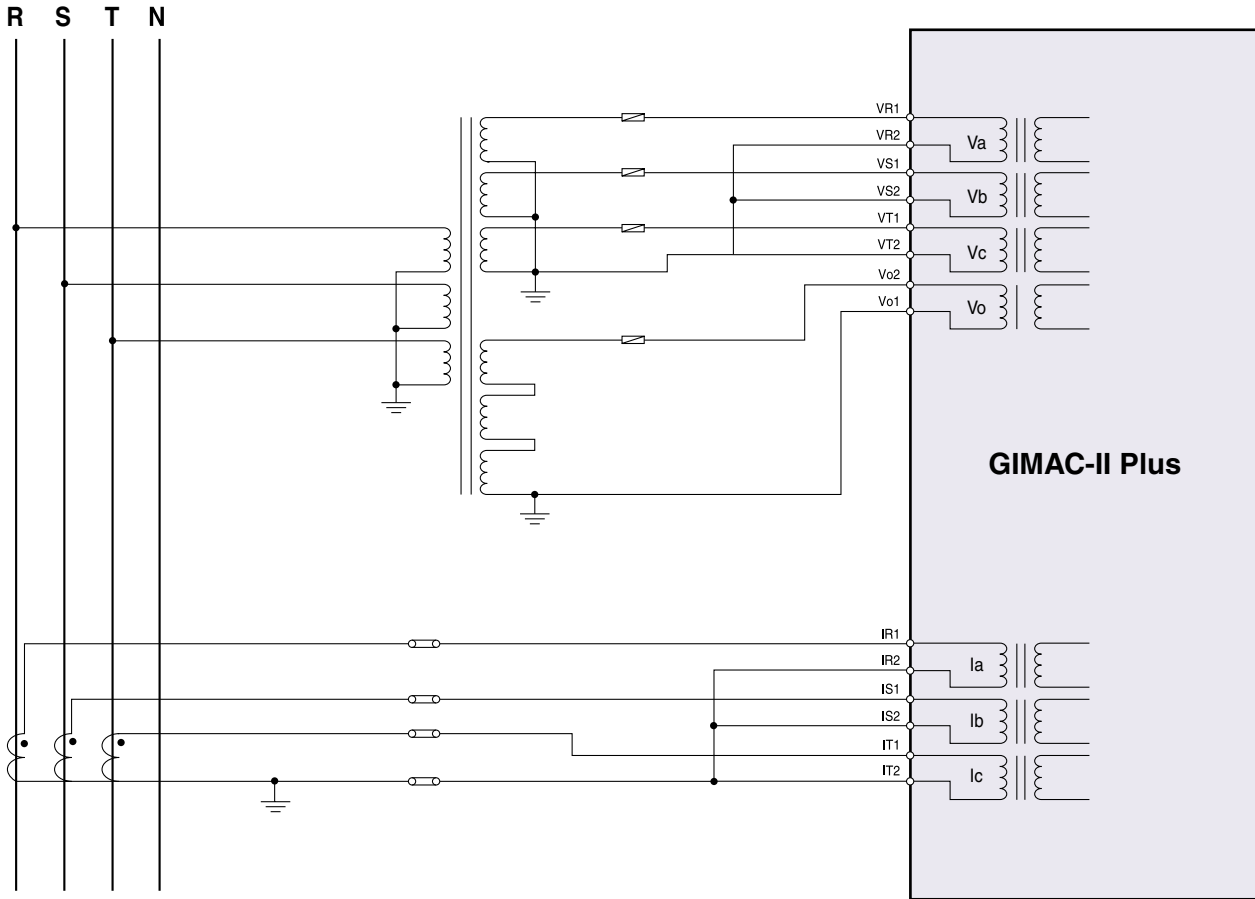

1P3W

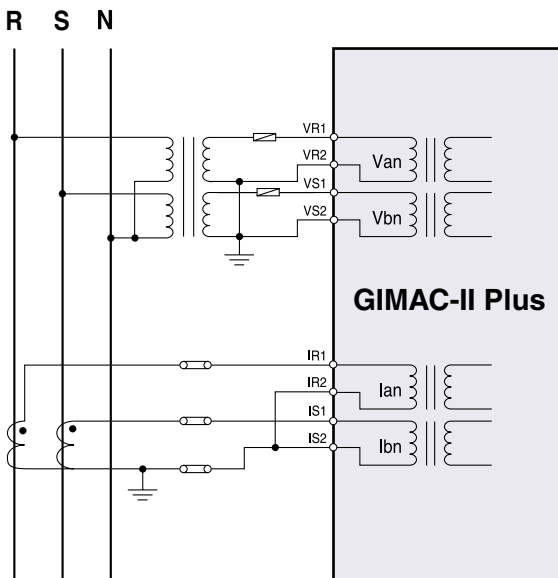

1P2W

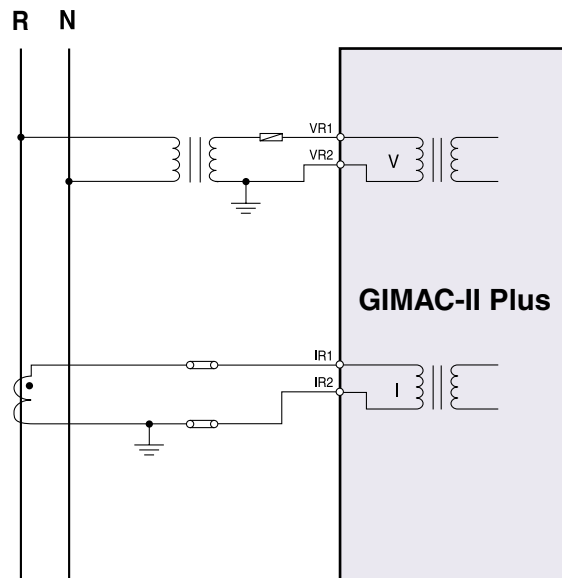

Dimension & Ordering

Dimension

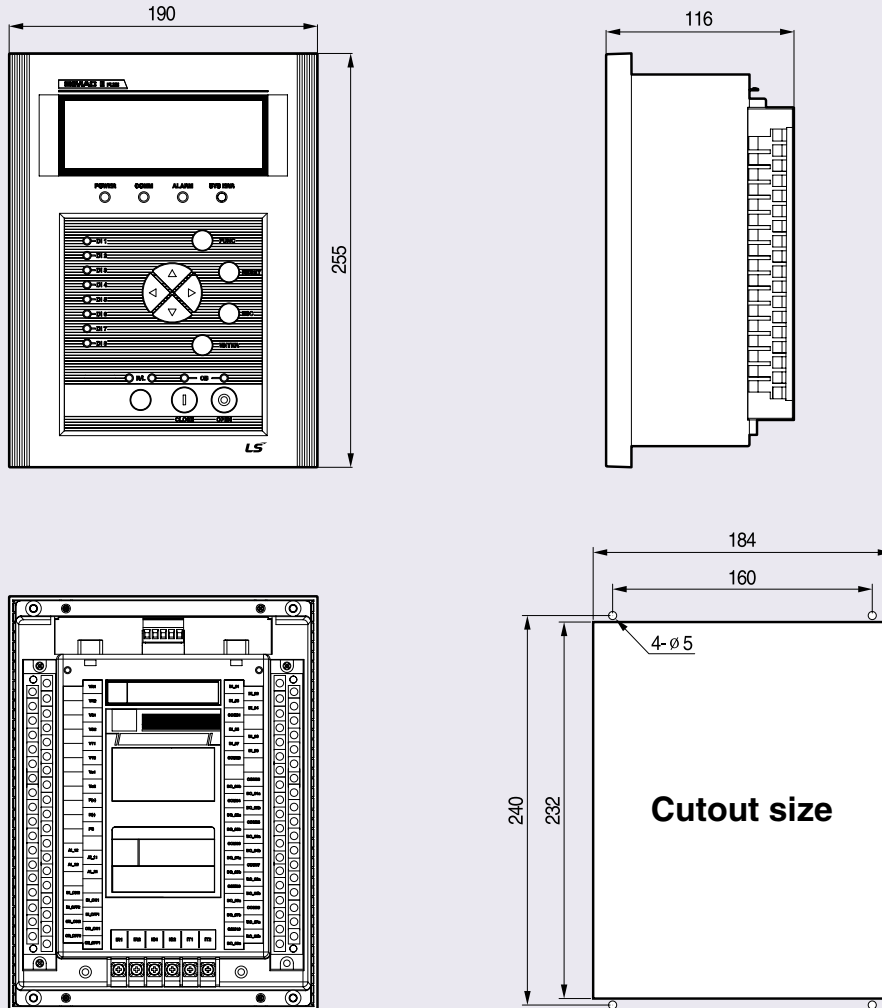

Ordering

GIMAC-115plus

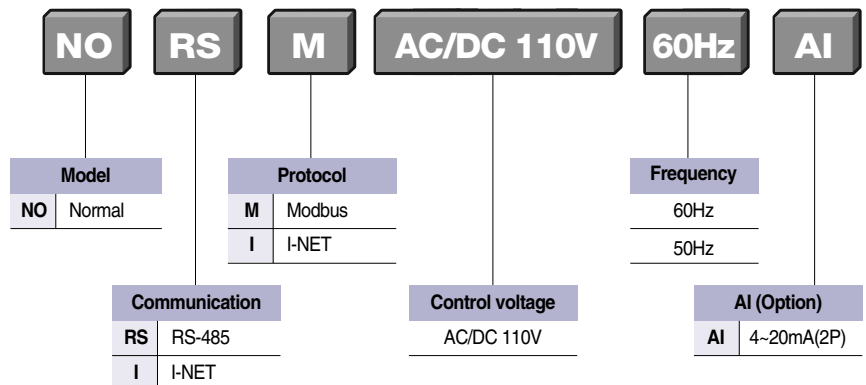

GIMAC-i



Digital Power Meter



Various measurement functions
High accuracy (0.3%)



Compact size (144 × 144 × 85mm)
- DIN 96 & ANSI"4 cutout size



Wide voltage range
- AC 10 ~ 452V



MODBUS/RS-485



Control voltage AC/DC 88~264V



Protecting mis-wiring



IEC 60255, KEMC 1110
ISO 9001, ISO 14001





Contents :

Technical specifications	0-5-4
External	0-5-6
Wirings	0-5-7
Dimension & Ordering	0-5-9



Digital Power Meter

Technical specifications

Rating

Model	GIMAC-i	
Wirings	1P2W, 1P3W, 3P3W, 3P4W	
Input	Frequency	50Hz / 60Hz
	Voltage	PT AC 10~452V
	Current	CT 0.05~6A
	Control voltage	AC/DC 88~264V (Free voltage)
	Power consumption	Max. 2W
	Burden	PT Max. 0.5VA CT Max. 0.5VA
Insulation Resistance	Over DC 500V 100M Ω	
Insulation Voltage	AC 2kV (1kV) / 1min	
Impulse Voltage	AC 5kV (3kV) / 1.2 \times 50 μ s	
Overload withstand	Current circuit	2 In for 3 hours 20 In for 2 seconds
	Voltage circuit	1.15 Vn for 3 hours
Fast Transient Disturbance	Power Input 4kV	
ESD(Electrostatic Discharge)	Air 8kV	
	Contact 6kV	
Operation temperature	-10°C ~ 55°C	
Storage temperature	-25°C ~ 70°C	
Humidity Average	30 ~ 80%	
Altitude	1000m and below	
Others	Non-impact place Non-air pollution place	
Standard	IEC 60255, IEC61000-4	
Communication	MODBUS/RS-485	
Dimension(W \times H \times D)	144 \times 144 \times 85 (mm)	
Weight	0.52 kg	

Self-diagnosis

Item	LCD display
Mis-wiring	Conn Chc (connection check)
Memory error	ERROR 1
Power fail	ERROR 2
Option error	ERROE 3
Setting error	ERROR 4
Calibration error	ERROR 5

Measurement functions

Parameters		NO	EX	Accuracy(%)	Remarks
Voltage	Vavg	■	■	±0.3%	-
	Vab, Vbc, Vca	■	■	±0.3%	-
	Va, Vb, Vc	■	■	±0.3%	-
Current	Iavg	■	■	±0.3%	-
	Ia, Ib, Ic	■	■	±0.3%	-
	Load factor Ia, Ib, Ic	■	■	-	-
Phase	∠VabVbc, ∠VabVca	-	■	±0.5°	3P3W
	∠VabIa, ∠VabIb, ∠VabIc	-	■	±0.5°	3P3W
	∠VaVb, ∠VaVc	-	■	±0.5°	3P4W
	∠VaIa, ∠VbIb, ∠VcIc	-	■	±0.5°	3P4W
Power	P	■	■	±0.5%	IEC 1036
	Pa, Pb, Pc	-	■	±0.5%	IEC 1036
	Q	■	■	±0.5%	IEC 1036
	Qa, Qb, Qc	-	■	±0.5%	IEC 1036
	S	■	■	±0.5%	IEC 1036
	Sa, Sb, Sc	-	■	±0.5%	IEC 1036
Energy	Wh	■	■	±0.5%	IEC 1036
	Varh	■	■	±0.5%	IEC 1036
	rWh	-	■	±0.5%	IEC 1036
	rVarh	-	■	±0.5%	IEC 1036
	VAh	■	■	±0.5%	IEC 1036
Frequency	F(Hz)	■	■	0.05Hz	-
Power factor	PF	■	■		+ : Lag - : Lead
	PFa, PFb, PFC	-	■		
	DPFa, DPFB, DPFC	-	■		
THD	THD(V)	-	■	-	Va(ab), Vb(bc), Vc(ca)
	THD(I)	-	■	-	Ia, Ib, Ic
Harmonics	1 st ~ 15 th Harmonics (V)	-	■	-	Va(ab), Vb(bc), Vc(ca)
	1 st ~ 15 th Harmonics (I)	-	■	-	Ia, Ib, Ic
Demand	Demand W	-	■	-	
	Demand Ia, Ib, Ic, Iavg	-	■	-	-
MAX	max Ia, max Ib, max Ic, max Iavg max Va(ab) THD, max Vb(bc) THD	-	■	-	-
	max Vc(ca) THD max Ia THD, max Ib THD,	-	■	-	-
	max Ic THD	-	■	-	-
	max W	-	■	-	-
	max VAR	-	■	-	-
	max VA	-	■	-	-
	max Demand Iavg, Ia, Ib, Ic	-	■	-	-
	max Demand W	-	■	-	-

Digital Power Meter

External

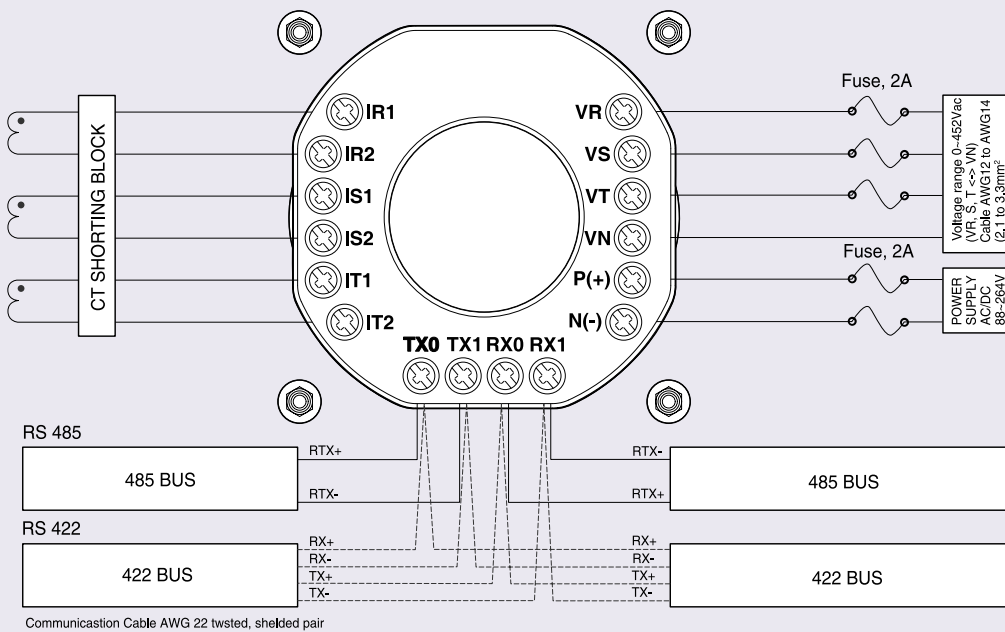
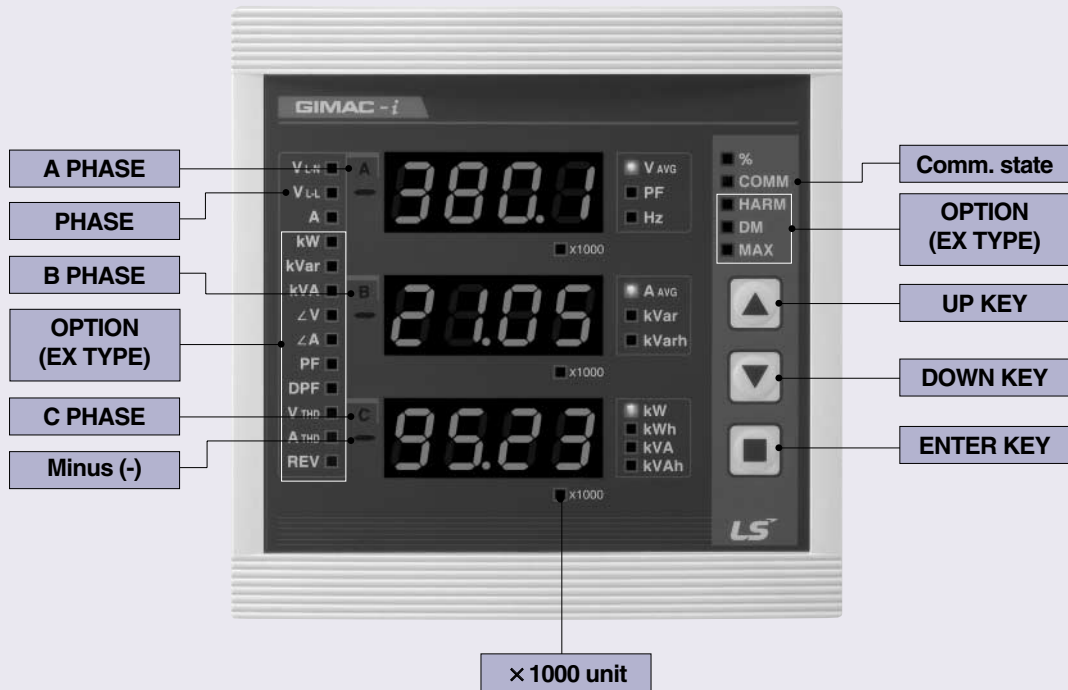

Wirings

3P4W

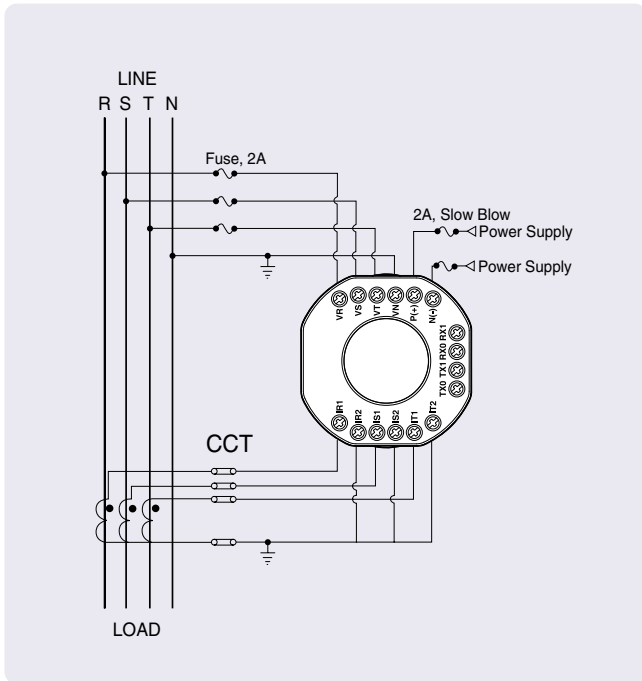

Direct wiring

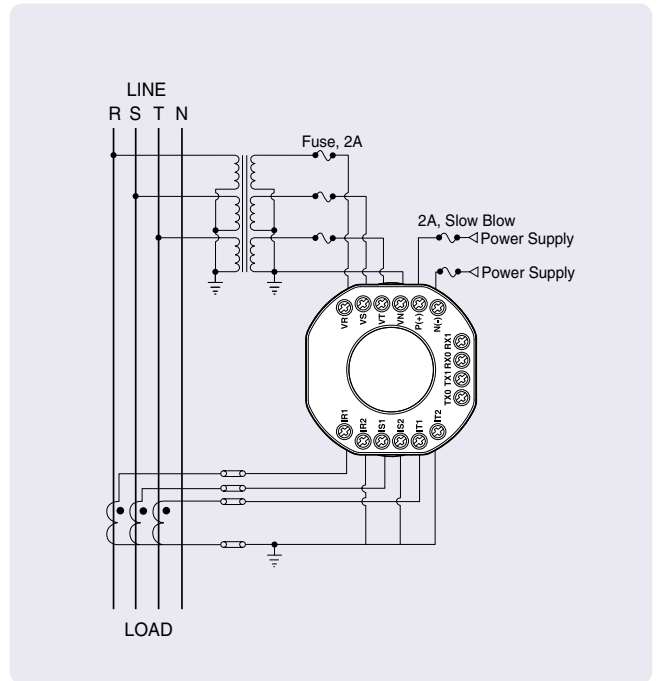

PT application

3P3W

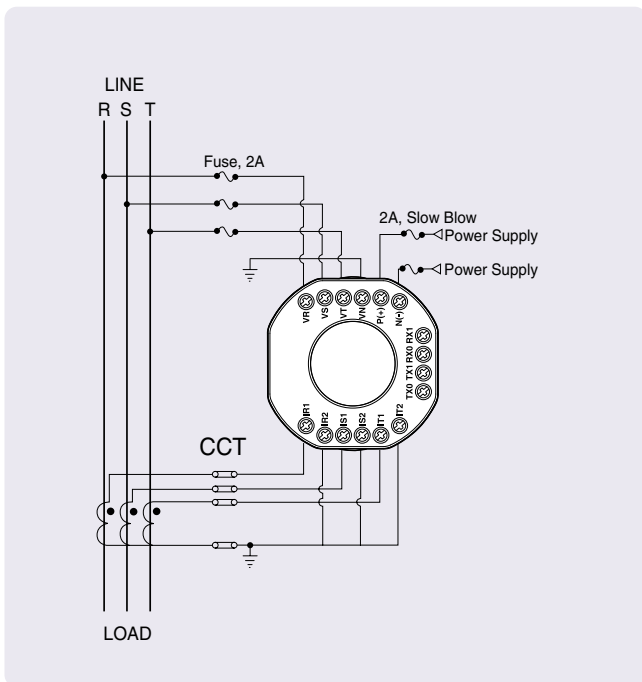

Direct wiring

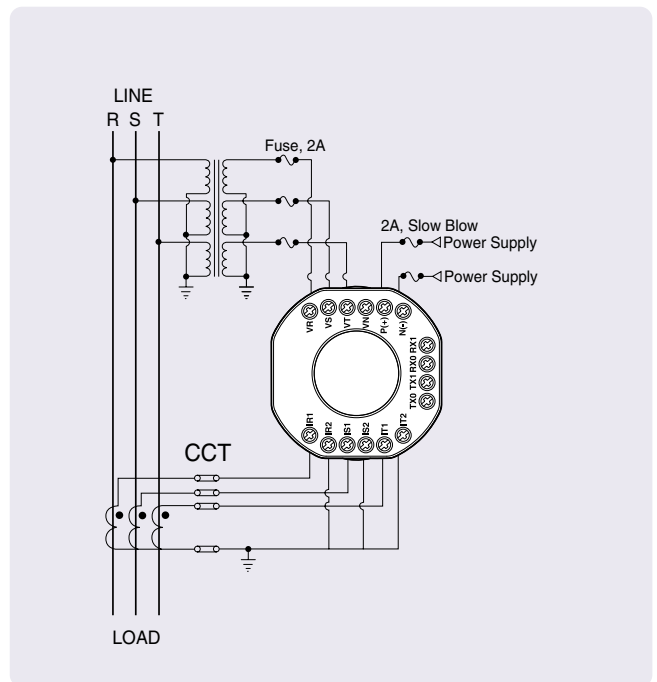

PT application

Digital Power Meter

Wirings

3P3W (Open Delta)

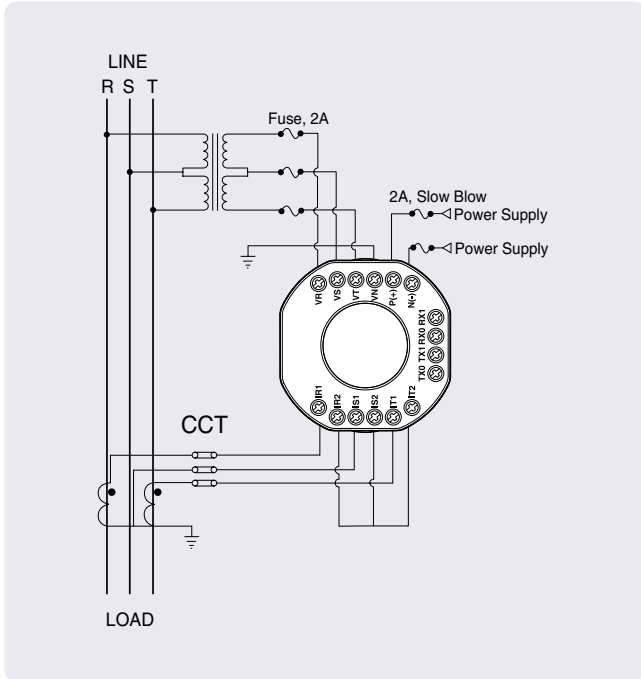

1P 3W

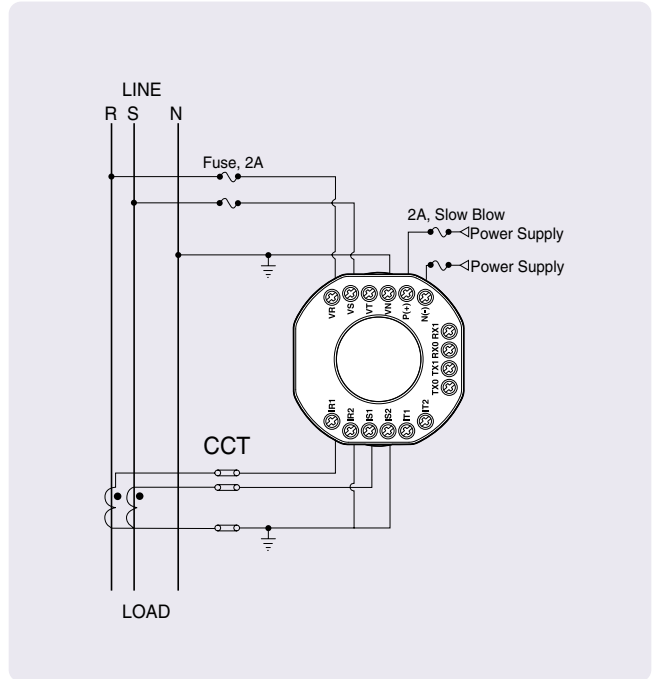

1P 2W

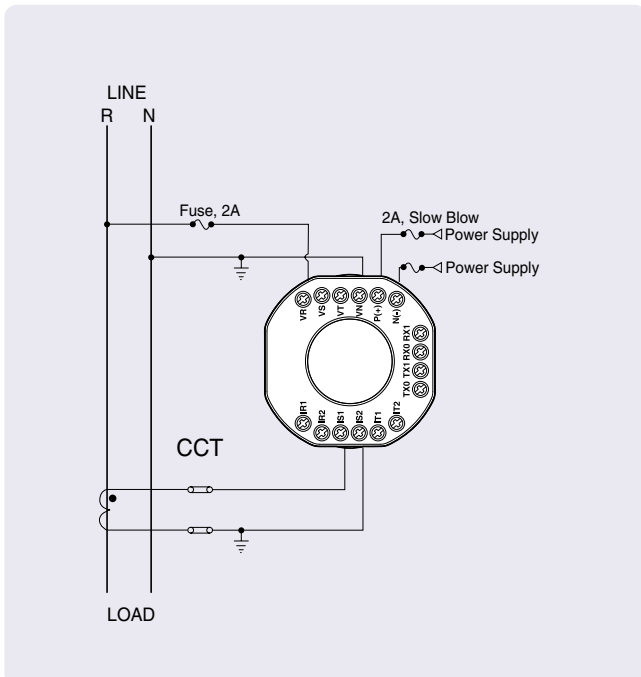

Dimension & Ordering

Dimension

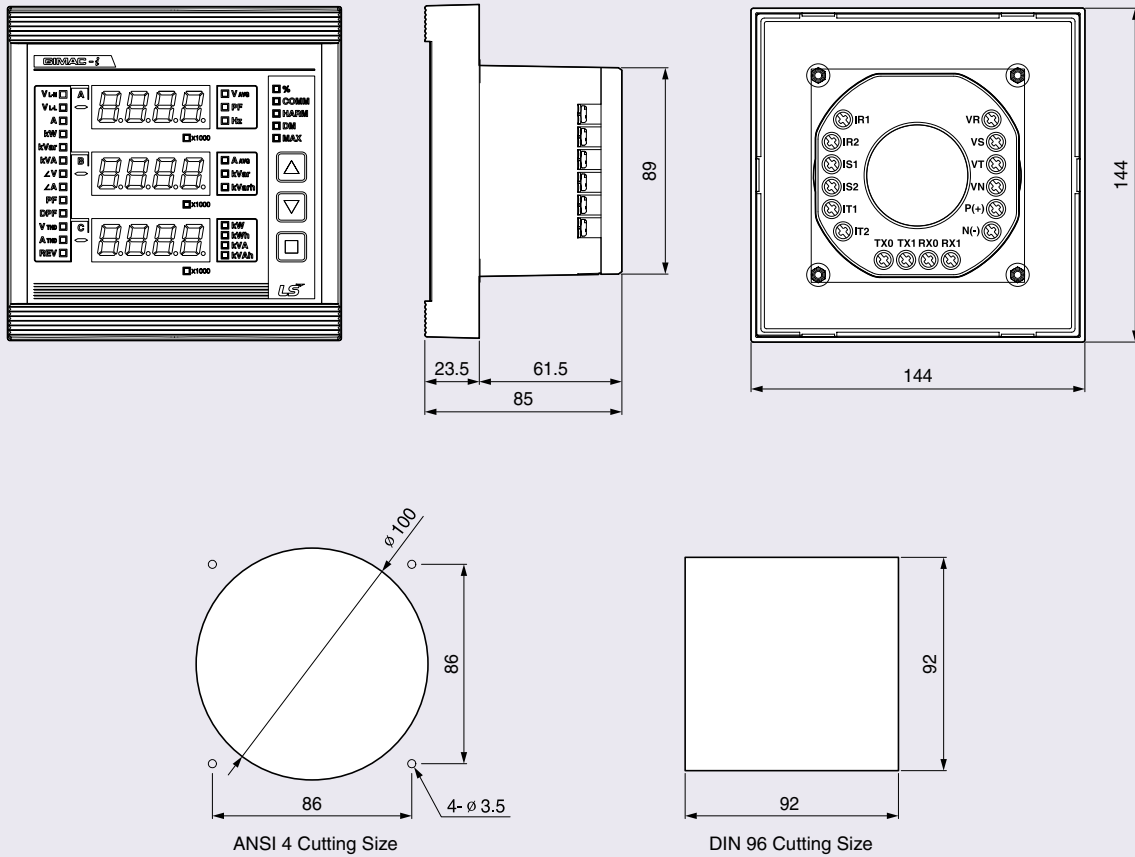

Ordering

GIMAC-i

NO

M485

AC/DC 88~264V

60Hz

Digital Power Meter

Model	
NO	Normal
EX	Expansion

Communication	
-	Without Comm.
M485	Modbus/RS-485
M422	Modbus/RS-422

Control voltage
AC/DC 88~264V

Frequency
60Hz
50Hz

GIMAC-DC



DC Meter



IEC 60255, KEMC 1110
ISO 9001, ISO 14001



Measurement DC voltage, DC current
High accuracy (0.3%)



Compact size (144 × 144 × 85mm)
- DIN 96 & ANSI"4 cutout size



Wide voltage range
- AC 10~452V, DC 20~264V



Control voltage AC/DC 88~264V



MODBUS/RS-485, 422





O₆



Contents :

Technical specifications	O-6-4
External	O-6-5
Wirings	O-6-6
Dimension & Ordering	O-6-7



Digital Integrated Meter

Technical specifications

Rating

Model		GIMAC-DC
Input	Frequency	50Hz / 60Hz
	Voltage PT	AC 20~452V, DC 20~264V
	Control voltage	AC/DC 88~264V (Free voltage)
	Power consumption	Max. 10W
	Burden PT	Max. 0.5VA
Insulation Resistance		Over DC 500V 100MΩ
Insulation Voltage		AC 2kV (1kV) / 1min
Impulse Voltage		AC 5kV (3kV) / 1.2 × 50μs
Overload withstand	Current circuit	2 In for 3 hours 20 In for 2 seconds
	Voltage circuit	1.15 Vn for 3 hours
Fast Transient Disturbance		Power Input 4kV DC Input 2kV
ESD(Electrostatic Discharge)		Air 8kV Contact 6kV
Operation temperature		-10°C ~ 55°C
Storage temperature		-25°C ~ 70°C
Humidity		Average 30 ~ 80%
Altitude		1000m and below
Others		Non-impact place Non-air pollution place
Standard		IEC 60255, IEC61000-4
Communication		MODBUS/RS-485
Dimension(W × H × D)		144 × 144 × 85 (mm)

Measurement functions

Parameters		Measurement	Accuracy(%)
AC voltage	AC voltage	Vac	±0.30%
	frequency	Hz	±0.05Hz
	THD	THD	-
DC voltage	DC voltage	Vdc	±0.30%
DC current	Output current	Iout	±0.50%
	Battery current	Ibat	±0.50%
MAX	AC voltage	MAX Vac	-
	THD	MAX THD	-
	DC voltage	MAX Vdc	-
	Output current	MAX Iout	-
	Battery current	MAX Ibat	-

External

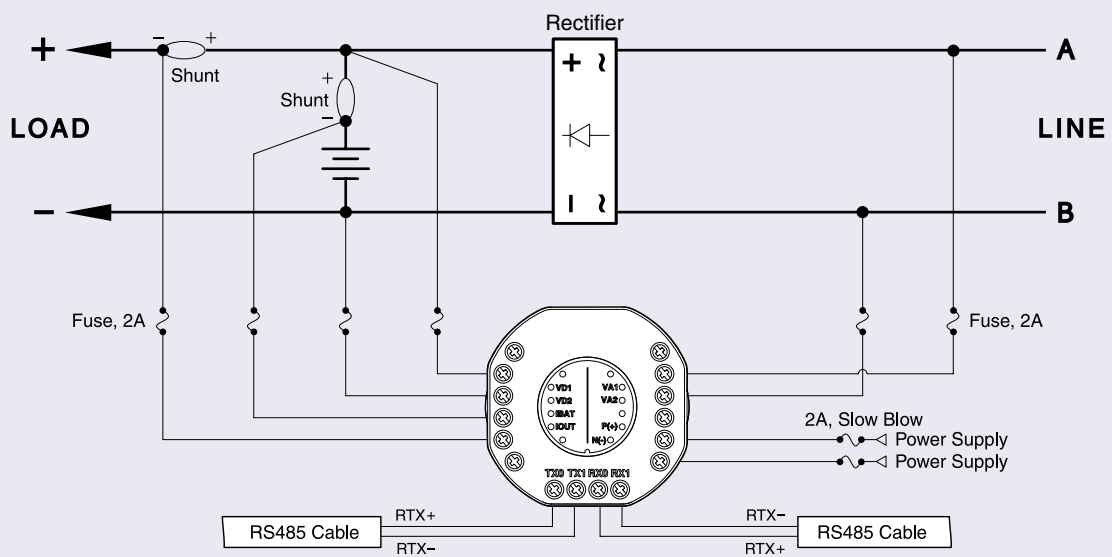
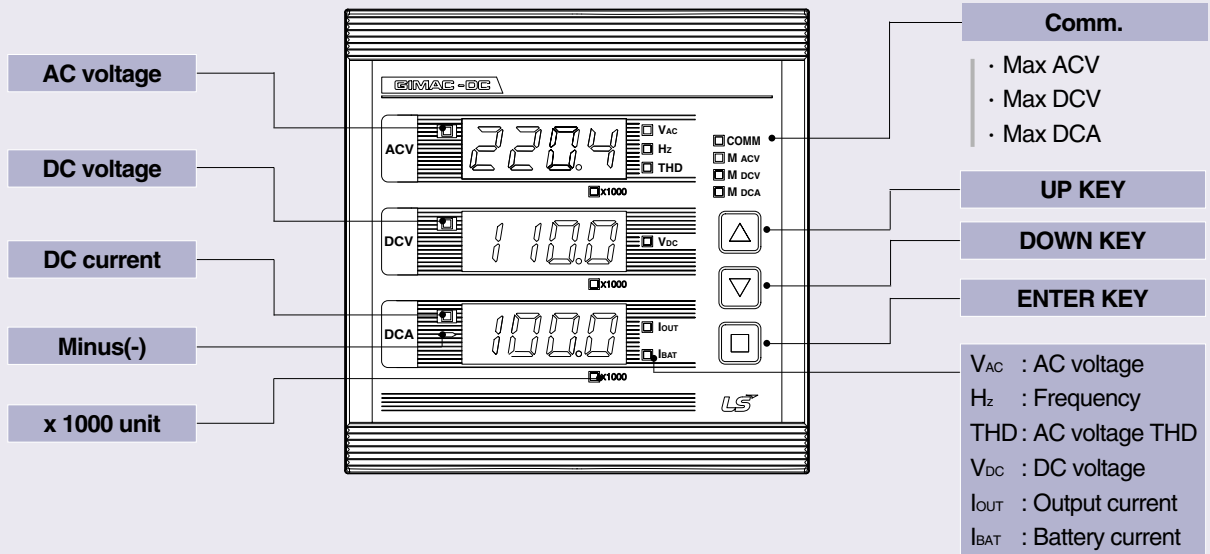

Dimension & Ordering

Dimension

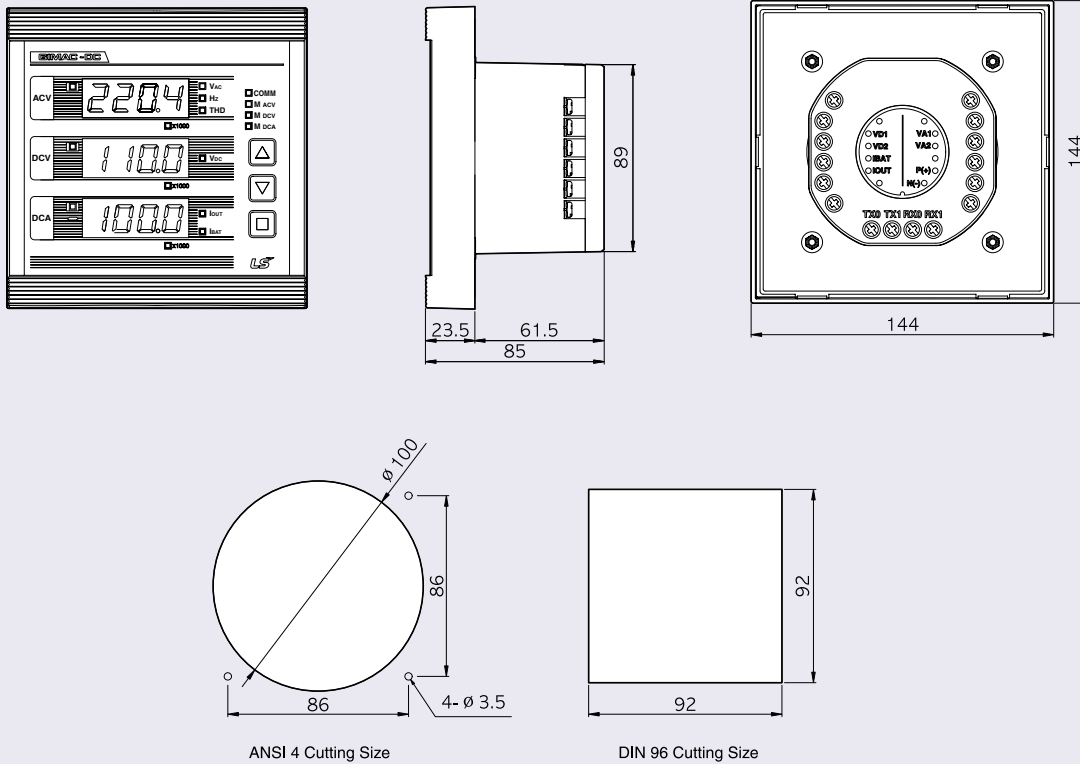

Ordering

GIMAC-DC

M485

AC/DC 88~264V

60Hz

Communication	
-	Without Comm.
M485	Modbus/RS-485

Control voltage
AC/DC 88-264V

Frequency
60Hz
50Hz

Green Innovators of Innovation



Safety Instructions

- For your safety, please read user's manual thoroughly before operating.
- Contact the nearest authorized service facility for examination, repair, or adjustment.
- Please contact a qualified service technician when you need maintenance. Do not disassemble or repair by yourself!
- Any maintenance and inspection shall be performed by the personnel having expertise concerned.

LSIS Co., Ltd.

© 2009.2 LSIS Co.,Ltd. All rights reserved.

www.lsis.biz

■ HEAD OFFICE

LS Tower 1026-6, Hogue-dong, Dongan-gu,
Anyang-si, Gyeonggi-do 431-848, Korea
Tel. (82-2)2034-4887, 4873, 4148
Fax. (82-2)2034-4648

■ CHEONG-JU PLANT

Cheong-Ju Plant #1, Song Jung Dong, Hung Duk Ku,
Cheong Ju, 361-720, Korea

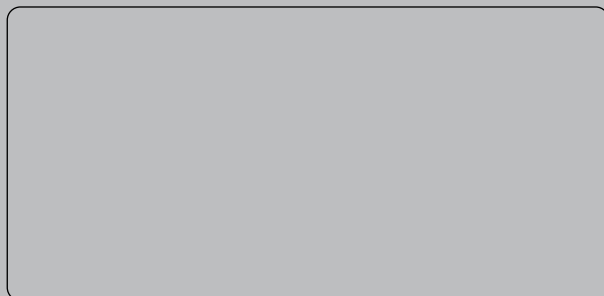

Specifications in this catalog are subject to change without notice due to continuous product development and improvement.

■ Global Network

- **LSIS (Middle East) FZE >> Dubai, U.A.E.**
Address: LOB 19 JAFZA VIEW TOWER Room 205, Jebel Ali Freezone P.O. Box 114216, Dubai, United Arab Emirates
Tel: 971-4-886 5360 Fax: 971-4-886-5361 e-mail: jungyongl@lsis.biz
- **Dalian LSIS Co., Ltd. >> Dalian, China**
Address: No.15, Liaohexi 3-Road, Economic and Technical Development zone, Dalian 116600, China
Tel: 86-411-8273-7777 Fax: 86-411-8730-7560 e-mail: lixx@lsis.com.cn
- **LSIS (Wuxi) Co., Ltd. >> Wuxi, China**
Address: 102-A, National High & New Tech Industrial Development Area, Wuxi, Jiangsu, 214028, P.R.China
Tel: 86-510-8534-6666 Fax: 86-510-522-4078 e-mail: xuhg@lsis.com.cn
- **LSIS-VINA Co., Ltd. >> Hanoi, Vietnam**
Address: Nguyen Khe - Dong Anh - Ha Noi - Viet Nam
Tel: 84-4-882-0222 Fax: 84-4-882-0220 e-mail: srjo@lsisvina.com
- **LSIS-VINA Co., Ltd. >> Hochiminh, Vietnam**
Address: 41 Nguyen Thi Minh Khai Str. Yoco Bldg 4th Floor, Hochiminh City, Vietnam
Tel: 84-8-3822-7941 Fax: 84-8-3822-7942 e-mail: sbpark@lsisvina.com
- **LSIS Shanghai Office >> Shanghai, China**
Address: Room E-G, 12th Floor Huamin Empire Plaza, No.726, West Yan'an Road Shanghai 200050, P.R. China
Tel: 86-21-5237-9977 (609) Fax: 89-21-5237-7191 e-mail: jinhk@lsis.com.cn
- **LSIS Beijing Office >> Beijing, China**
Address: B-Tower 17FL.Beijing Global Trade Center B/D. No.36, BeiSanHuanDong-Lu, DongCheng-District, Beijing 100013, P.R. China
Tel: 86-10-5825-6025,7 Fax: 86-10-5825-6026 e-mail: cuixiaorong@lsis.com.cn
- **LSIS Guangzhou Office >> Guangzhou, China**
Address: Room 1403,14F,New Poly Tower,2 Zhongshan Liu Road,Guangzhou, P.R. China
Tel: 86-20-8326-6764 Fax: 86-20-8326-6287 e-mail: linsz@lsis.biz
- **LSIS Chengdu Office >> Chengdu, China**
Address: Room 1701 17Floor, huanminhanjun international Building, No1 Fuxing Road Chengdu, 610041, P.R. China
Tel: 86-28-8670-3101 Fax: 86-28-8670-3203 e-mail: yangcf@lsis.com.cn
- **LSIS Qingdao Office >> Qingdao, China**
Address: 7B40,Haixin Guangchang Sheny Building B, No.9, Shandong Road Qingdao 26600, P.R. China
Tel: 86-532-8501-6568 Fax: 86-532-583-3793 e-mail: lirj@lsis.com.cn
- **LSIS NETHERLANDS Co.Ltd >> Qingdao, Netherlands**
Address: 1st. Floor, Tupolevlaan 48, 1119NZ,Schiphol-Rijk, The Netherlands
Tel: 31-20-654-1420 Fax: 31-20-654-1429 e-mail: junshickp@lsis.biz
- **LSIS Gurgaon Office >> Gurgaon, India**
Address: 109 First Floor, Park Central, Sector-30, Gurgaon- 122 002, Haryana, India