



## Digital Protection & Measurement Device

# GIPAM-2000/2200



## Digital Integrated Protection & Monitoring Device

The optimum protection which leads protective diagnosis and reliability improvement of own protection relay, quick accident analysis and maintenance & repair, preventive control, minimizing accident spread.



IEC 60255, KEMC 1120  
ISO 9001, ISO 14001





## Contents :

Features .....	N-1-8
Technical Specifications .....	N-1-9
Communications .....	N-1-11
External & Structure .....	N-1-12
Man Machine Interface .....	N-1-14
System Configuration .....	N-1-18
Characteristics .....	N-1-20
Time Characteristic Curves .....	N-1-25
Wirings .....	N-1-29
Contact Usage .....	N-1-37
Dimension .....	N-1-41
Ordering .....	N-1-43



## **GIPAM-2000/2200**

series are multifunction microprocessor-based protection equipments suitable for all types of application such as distribution feeders. It can be also be used for management backup protection of incomings, feeders, transformers and high tension motors.



## Digital Integrated Protection & Monitoring Equipment

Over current protection function includes protection elements such as over current, over current ground fault, selective ground fault current, directive ground fault current, negative sequence over current in each phase with regard to time delay or instantaneous elements. Moreover, it supports under voltage, over voltage, ground fault over voltage, phase reversal over voltage, etc. regarding voltage protection and thermal overload, rocked rotor, differential, ground fault differential regarding various kinds of protection functions. As it has differential, ground fault differential to protect a transformer, and the protection of secondary wires transformer is available too.

GIPAM-2000/2200 can arrange easily as demand of users' need as well as apply to various sequences because the logic design through a simple logic program is available regarding input/output contacts.

GIPAM-2000/2200 series provides various monitoring, measuring functions and it does easy accident analysis by storing data fires such as 800 events, 200 faults and maximum 64 .or. 128 cycle' s fault waveform. Furthermore, when accidents happens, alarm signal can put out during the operation in terms of self testing.

GIPAM-2000/2200 series provide IrDA Serial Ports for



connecting PC which is performing the operation program, and they are equipped with RS-485, optic communication ports to communicate with the upper systems. In addition, they support DNS 3.0, MODBUS protocol widely spread in the industrial electric section and I-NET which is the exclusive express communication system by LSIS.

Setting all protection function and monitoring as well as checking many kinds of functions are available through the operation program based on PC interface.

# Digital Integrated Protection & Monitoring Device

## Features

### Easy GIPAM-2000/2200 Setting

GIPAM-2000/2200 series is simple to set all relay functions and verify all supported functions through the offered operation program (GIPAM OPTO MASTER) which is based on PC interface. After setting the each parameter, downloading data from the communication port on the front of GIPAM-2000/2200 series leads completion of setting. It is very easy to maintain and repair due to the availability of download & upload.



<GIPAM-2000>



### MIMIC Diagram & Graphic LCD

The 320×240 graphic LCD of GIPAM-2000 features a convenient MMI and various types of display. MIMIC diagram especially displays the system that GIPAM-2000 has been applied to in the form of a one-line diagram so as to see them at a glance, which enables easily the checking of operating status of the devices such as contacts or breakers according to the output of GIPAM-2000. MIMIC diagram can be designed in the operational program for the PC Interface by user.

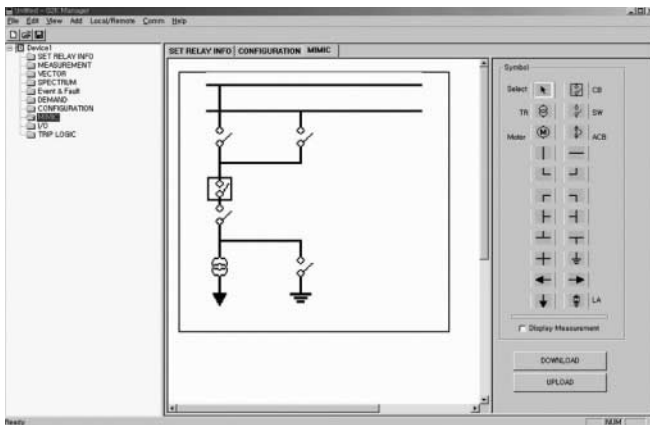

### Harmonic Spectrum

GIPAM-2000 can display the harmonic analysis SPECTRUM, which enables the measurement and verification of current and voltage from the 2nd harmonic to 13th harmonic and THD (Total Harmonic Distortion) can be displayed together.

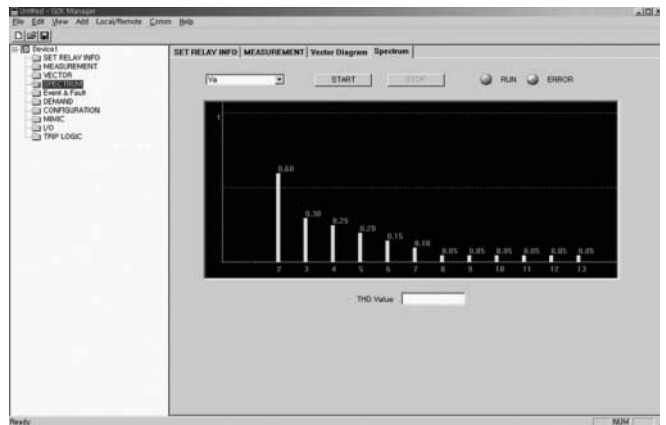

## EVENT & FAULT RECORDING

GIPAM-2000/2200 is able to store up to 800 events that are related to Protection & Measuring function, Breaker operation, Contact trip, operation information, and selfdiagnosis outcome. Moreover, in case of line and load fault incidents, GIPAM-2000/2200 can store up to 200 detailed information regarding fault analysis, current fault, and voltage fault

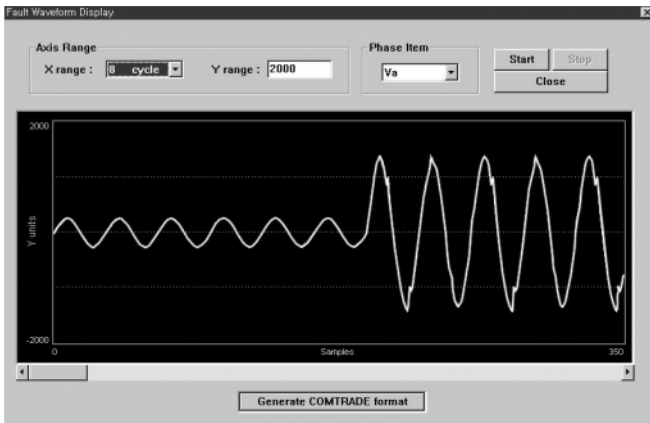

Fault waveforms are saved as a Comtrade (IEEE) file format to be analyzed its waveforms or used for fault simulations.

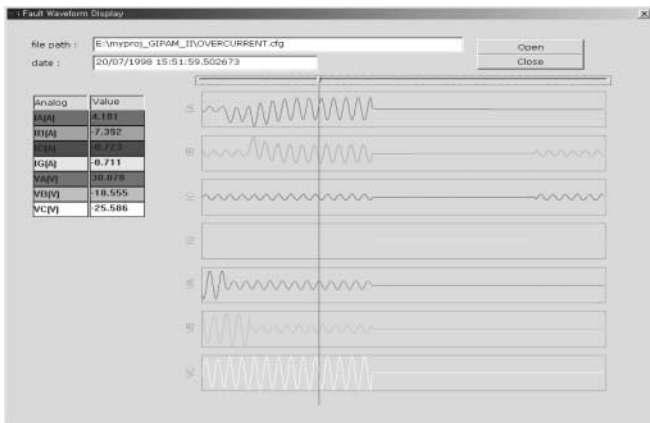

## Sequence of Event(SOE) Function

GIPAM-2000/2200 supports the SOE function that makes easy for reviewing fault analysis and operation information by recording events in sequence at 1ms' intervals regarding internal protection relay, breaker operation, or self-diagnosis abnormalities such as alarm contact output and others. These events including the latest registered one can be stored as many as 800. Each event can be verified in detail under the "EVENT LIST" section from the initial screen of "EVENT/FAULT REC" Menu. In addition, it is possible to save as files with GIPAMManager (capable to manage more than 800).

## Vector Diagram

GIPAM-2000/2200 can display a vector diagram regarding the system's voltage, current, and phase through PC interface operating program. It is easy to comprehend its electric system's condition because of visualization from the diagram that verifies the amount of electricity.

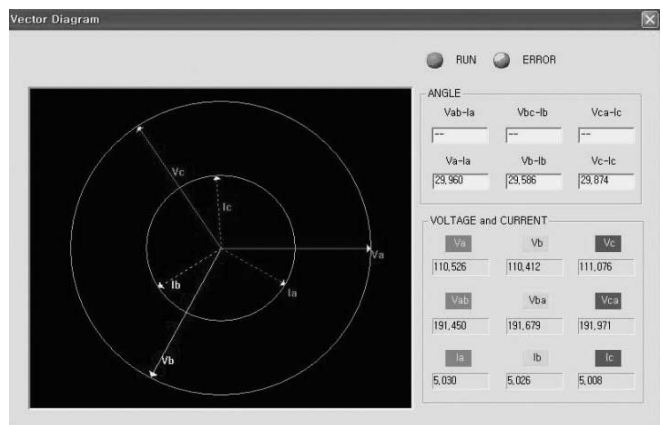

## Time Characteristic Curve

By operating PC interface operating program, it is possible to verify time characteristic curves to check with arranged values after setting each protection relay. Therefore, it is very convenient to program protection relay. Besides, it is simple to make protection coordination among electric systems as well.

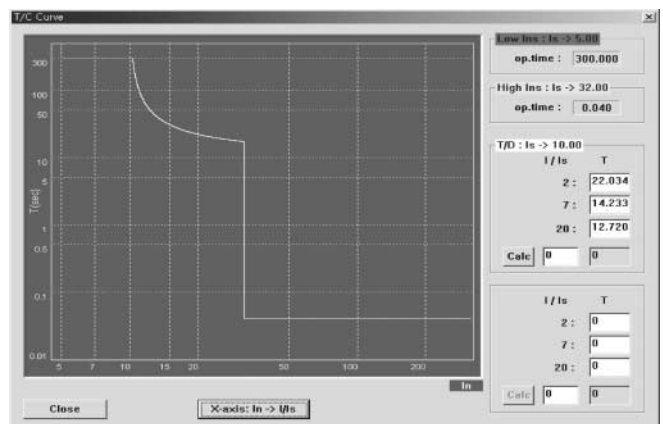

# Digital Integrated Protection & Monitoring Device

## Features

### Select Before Operating(SBO) and Check Before Operating(CBO) Function

By choosing controlling Points first before sending out orders to where it is desired to control, control orders are executed only along with normal responses. This function enhances to control reliability and security. GIPAM-2000/2200 applies SBO/CBO functions at CB control's power contact points. For selected control point, it will wait for control orders for 5 seconds after its response. If the control order won't be delivered within 5 seconds, it will be reset. The control functions will be executed only on the normal condition when orders were delivered within 5 seconds,

### Various Communication Compatibilities

GIPAM is possible to select its communication from RS-485/422, Optic, Ethernet and I- NET. Its application to diverse systems is convenient in the industrial sites, because it supports various protocols such as DNP 3.0, IEC 60870, MODBUS and exclusive I-NET protocol as well. Not only it is able to support the Ethernet communication mode through a protocol transformer enabling high speed data communications, but also it is possible to make up differentiated systems using H.A.(High Availability) communication supports. Moreover, the product's front side is equipped with an IrDA(infrared rays) port to provide easy access to upload/download with PC

### TRIP LOGIC and SEQUENCE

Including a trip relay, GIPAM-2000/2200 series' all I/O contact points and protection relay's operation signals can be managed by the logic that is directly designed by users. The logic can be easily arranged by using provided PC operating program, and applied to a variety of sequences.

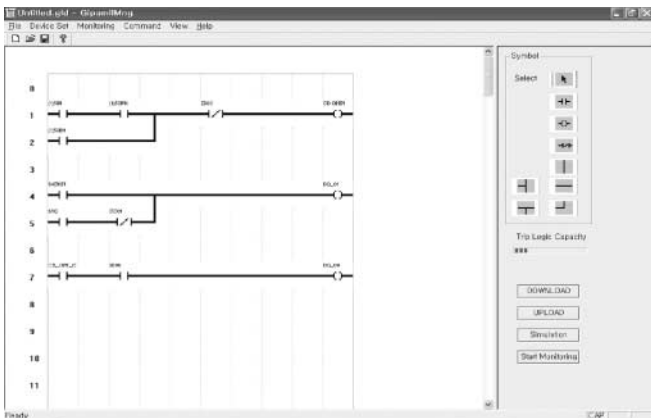

### ANALOG INPUT (OPTION)

GIPAM-2200 is able to measure various analog data such as distribution panels' internal temperatures, transformer temperature, motor's internal stator and bearing temperatures, and rectifier's AC/DC voltage and current through its analog contacts(4point) without using additional TD.

- AI input variation : DC 4~20mA
- Number of Contact Point : 4point
- Display method : User Define
- Accuracy rate : 0.2% at Full scale

### TRIP CIRCUIT SUPERVISION (TCS) & TRIP RELAY SUPERVISION (TRS)

To check circuit's condition, GIPAM-2000/2200 internally make micro-current to flow on a trip circuit that is composed of breaker's trip coil and control voltage, and trip relay; and tests it every hour. By composing trip relay with 2 pole series, not 1 pole by itself, it will execute contact operation at regular cycle or requested time checking trip relay automatically without operation of a circuit breaker. After the automatic check-up, the result will be recorded as event and if fault happens, contact output will be printed to prevent accidents in advance.

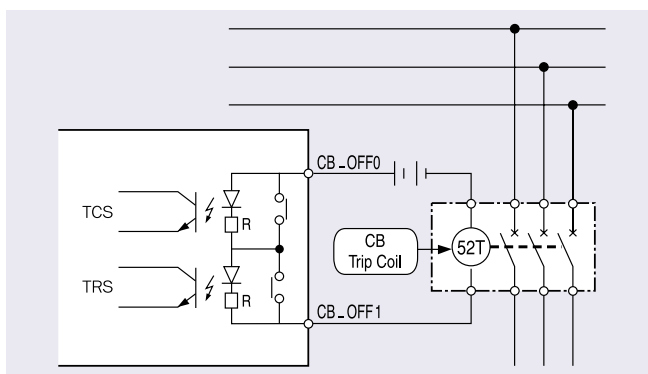

### CIRCUIT BREAKER FAILURE (CBF)

GIPAM-2000/2200 supports breaker failure function that can prevent further extension of accident by controlling upper circuit breaker to trip, when lower circuit breaker failed to act despite protection relay was activated and sent trip signal for problems in the circuit. This function is not limited only on trip signal, but also includes CB Close/Open control failure, it will produce alarm output as well.

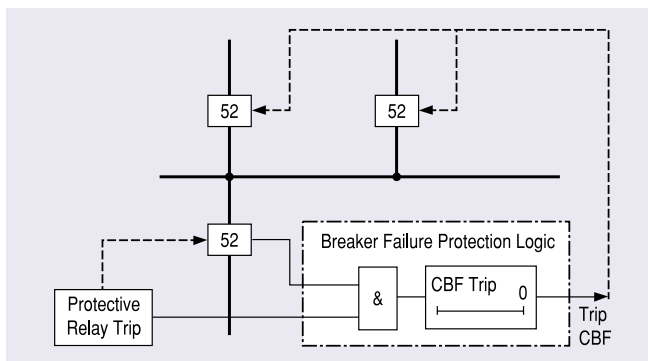

### PT(VT) FAILURE

By detecting PT 2nd fuse melt-down in advance, it's possible to collect alarm message and logic prints which can be used to prevent unnecessary system cutoffs by protection relay operation of UVR and NSOVR. It does not activate under under-voltage or blackout situation, it compares with voltage current and on breaker conditions to decide PT fuse opening. By utilizing DO output, it can generate alarm signal and it can also make Trip Block to disable trip function. Replacing PT fuse will reset it immediately.

# Technical Specifications

## Rating

Type		Specification	
Wiring		1P3W, 3P3W, 3P4W	
Input	Frequency	60Hz/50Hz	
	Voltage	PT	110V
		GPT	190V, 190/√3V
	Current	CT	5A (Option : 1A)
		ZCT	200/1.5mA
	Control Voltage	AC/DC 110V/125V	
	Power Consumption	Normal : Max. 30W, Operating : Max. 70W	
	Burden	PT	Max. 0.5VA
		CT	Max. 1.0VA
	Input Contact 6EA	Digital Input : AC/DC 110V/125V	
Output Contact	2EA for Power	AC 250V 16A / DC 30V 16A, Resistive Load 4000VA, 480W	
	10EA for Alarm	AC 250V 5A / DC 30V 5A, Resistive Load 1250VA, 150W	
Insulation Resistance		Over DC 500V 100MΩ	
Insulation Voltage		AC 2kV (1kV) / for 1 min	
Impulse Voltage		AC 5kV (3kV) Over 1.2 × 50μs	
Overload Withstand	Current circuit	3 In for 3 hours 20 In for 2 seconds	
	Voltage circuit	1.15 Vn for 3 hours	
Fast Transient Disturbance		Power Input 4kV Other Input 2kV (Analog input 1kV)	
ESD (Electrostatic Discharge)		Air 8kV Contact 6kV	
Operation temperature		-10°C ~ 55°C	
Storage Temperature		-25°C ~ 70°C	
Humidity		Average 30% ~ 80%	
Altitude		1000m and below	
Others		Non-impact place Non-air pollution place	
Standard		IEC 60255, IEC 61000-4, KEMC 1120	

# Digital Integrated Protection & Monitoring Device

## Technical Specifications

### Protection function

Type	Usage	Protection	
GIPAM-2000FI	Feeder Incoming	<ul style="list-style-type: none"> <li>· OCR (50/51)</li> <li>· DGR (67N)</li> <li>· UVR (27-1)</li> <li>· POR(47P)</li> </ul>	<ul style="list-style-type: none"> <li>· OCGR (50/51N)</li> <li>· OVR (59)</li> <li>· R-UVR (27R)</li> <li>· Reclosing (79)</li> <li>· SGR (67G)</li> <li>· OVGR (64G) <sup>3)</sup></li> <li>· NSOVR (47N)</li> <li>· Lock-out (86) <sup>2)</sup></li> </ul>
GIPAM-2000M	Motor	<ul style="list-style-type: none"> <li>· OCR (50/51)</li> <li>· DGR (67N)</li> <li>· NSOVR (47N)</li> <li>· 48/51LR</li> </ul>	<ul style="list-style-type: none"> <li>· OCGR (50/51N)</li> <li>· NSOCR (46)</li> <li>· THR (49)</li> <li>· Lock-out (86) <sup>2)</sup></li> <li>· SGR (67G)</li> <li>· POR (47P)</li> <li>· UVR (27-1)</li> </ul>
GIPAM-2000T	Transformer	<ul style="list-style-type: none"> <li>· DFR (87T)</li> <li>· OCGR (50/51N-1)</li> <li>· Lock-out (86) <sup>2)</sup></li> </ul>	<ul style="list-style-type: none"> <li>· OCR (50/51-1)</li> <li>· OCGR (50/51N-2)</li> <li>· OCR (50/51-2)</li> <li>· Inrush Detector (68) <sup>1)</sup></li> </ul>
GIPAM-2200 FN	Incoming Feeder Motor	<ul style="list-style-type: none"> <li>· OCR (50/51)</li> <li>· UVR (27)</li> <li>· NSOVR/POR (47)</li> <li>· 48/51LR</li> </ul>	<ul style="list-style-type: none"> <li>· OCGR (50/51N)</li> <li>· OVR (59)</li> <li>· NSOCR (46)</li> <li>· UCR (37)</li> <li>· DGR (67N)</li> <li>· OVGR (64)</li> <li>· THR (49)</li> <li>· NCH (66)</li> </ul>
GIPAM-2200 FZ		<ul style="list-style-type: none"> <li>· OCR (50/51)</li> <li>· UVR (27)</li> <li>· NSOVR/POR (47)</li> <li>· 48/51LR</li> </ul>	<ul style="list-style-type: none"> <li>· SGR (67G)</li> <li>· OVR (59)</li> <li>· NSOCR (46)</li> <li>· UCR (37)</li> <li>· OVGR (64G)</li> <li>· THR (49)</li> <li>· NCH (66)</li> </ul>
GIPAM-2200 T1	Transformer	<ul style="list-style-type: none"> <li>· DFR (87T-P)</li> <li>· OCR-2 (50/51)</li> <li>· OVGR (64)</li> </ul>	<ul style="list-style-type: none"> <li>· DFR (87T-G)</li> <li>· OCGR-1 (50/51N)</li> <li>· DGR-1 (67N)</li> <li>· OCR-1 (50/51)</li> <li>· OCGR-2 (50/51N)</li> <li>· DGR-2 (67N)</li> </ul>
GIPAM-2200 T2		<ul style="list-style-type: none"> <li>· DFR (87T-P)</li> <li>· OCR-2 (50/51)</li> <li>· OVGR (64)</li> </ul>	<ul style="list-style-type: none"> <li>· DFR (87T-G)</li> <li>· OCGR-1 (50/51N)</li> <li>· SGR-2 (67G)</li> <li>· OCR-1 (50/51)</li> <li>· DGR-1 (67N)</li> </ul>
GIPAM-2200 T3		<ul style="list-style-type: none"> <li>· DFR (87T-P)</li> <li>· OCR-2 (50/51)</li> <li>· OVGR (64)</li> </ul>	<ul style="list-style-type: none"> <li>· DFR (87T-G)</li> <li>· OCGR-2 (50/51N)</li> <li>· SGR-1 (67G)</li> <li>· OCR-1 (50/51)</li> <li>· DGR-2 (67N)</li> </ul>

Note) 1. DFR (87T) contains Inrush Detector (68).

2. Lock-out (86) can be configured as a PLC Trip Logic

3. OVGR is not connected to the CB\_OFF (TRIP circuit) . ( Modify the LOGIC if necessary )

### Measurement function

Measurement	Display range	Accuracy (%)	Remarks
Voltage (V)	0.00V ~ 999.99kV	±0.5%	Line voltage, Phase voltage
Zero phase voltage (Vo)	0.00V ~ 999.99V	±0.5%	Vo, Vo_max
Reverse phase voltage (V2)	0.00V ~ 999.99kV	±0.5%	
Current (A)	0.00A ~ 999.99kA	±0.5%	Phase current
Zero phase current (Io)	0.00A ~ 999.99A	±0.5%	Io(In), Io(In)_max
Reverse phase current (I2)	0.00A ~ 999.99kA	±0.5%	Displayed only at M type
Phase	0.00° ~ 360.00°	±0.5%	Phase between lines, between phases, between phase and current, between currents, between Zero phase Amps and voltage
Active power (W) <sup>1)</sup>	0.00W ~ 999.99MW	±0.5%	
Reactive power (VAR)	0.00VAR ~ 999.99MVAR	±1.0%	+ : Forward, - : Reverse
Apparent power (VA)	0.00VA ~ 999.99MVA	±1.0%	
Active Energy (WH)	0.00WH ~ 9999.99MWH	±1.0%	+ : Forward, - : Reverse
Reactive energy (VARH)	0.00VARH ~ 9999.99MVARH	±1.0%	
Frequency (F)	45 ~ 65Hz	±0.5%	
Power Factor (PF)	-1.000 ~ 1.000	±1.0%	
Fundamental Power Factor (DPF)	-1.000 ~ 1.000	±1.0%	cosθ, Lead (-)/Lag(+)
Voltage harmonics (%)	0.00 ~ 100.00 <sup>2)</sup>		Va(ab), Vb(bc), Vc(ca), Vo (n) of the 2 <sup>nd</sup> ~ 13 <sup>th</sup> harmonics and THD
Current harmonics (%)	0.00 ~ 100.00 <sup>2)</sup>		Ia, Ib, Ic, Io(n) of 2 <sup>nd</sup> ~ 13 <sup>th</sup> harmonics and THD
Active Power Demand	0.00W ~ 999.99MW <sup>2)</sup>		Total Peak Demand, Over Demand
Reactive Power Demand	0.00W ~ 999.99MVAR <sup>2)</sup>		Total Peak Demand, Over Demand
Current Demand	0.3A ~ 999.99kA <sup>2)</sup>		Each phase and total Peak Demand

Note) 1. Accuracy of Real power is based on the rating for PF = 1

2. Harmonics and Demand function applies only for GIPAM-2000

# Communications

GIPAM-2000/2200 provides baud rate up to 64kbps data transmission with the general RS-485 communication. In addition, RS-485/I-NET combo port and Fiber Optic (optical) port are provided, and DNP3.0 MODBUS protocol and I-NET (LSIS-dedicated) protocol are supported. The standard protocol, MODBUS protocol transmitting data at 100Mbps is applied to Ethernet communication method of GIPAM-2000

## 1 I-NET communication standards

I-NET is an express and high reliable communication which is designed with Custom LSI(GCV14605) ASIC Chip developed by LSIS.

- Baud rate: 250kbps
- Communication Line: Low capacitance LAN Interface cable
- Communication range: Maximum 1 km
- Specification: LIREV-AMEBSB 22AWG 2-pair (7/0.254TA)
- Isolation Method: Pulse Transformer
- Characteristic Impedance: 10MHz, 120Ω
- Connection Method: 4-Wire Multi-drop
- Termination: 2 Vertical 120Ω resistances are needed in the both sides of the line ends.
- Signal Modulation: Bipolar

## 2 DNS3.0, MODBUS / RS-485 Communication standards

- Operation mode: Differential
- Communication Range: Maximum 1.2km
- Communication Line: RS-485 shield twist 2-Pair cable
- Communication speed: Normally 19.2kbps~38.4bps
- Transmission Method: Half-Duplex
- Maximum Input/Output Voltage: -7V~+12V

## 3 DNS3.0, MODBUS/Optic Communication Standards (Optic Transceiver Specification)

- Wave Length: 820nm
- Fiber Size: 50/125, 62.5/125, 100/140 $\mu$ m
- Optical Connector Type: ST Type
- Optic Link Distance: Depends on Data rate, Maximum 4km (GIPAM-2200's Data bit rate: 9600bps ~ 230.4kbps)

## 4 MODBUS TCP/IP (GIPAM-2000)

- 100Base-TX  
Maximum baud rate: 100Mbps  
Topology: Star Type  
Transmission media: UTP(CAT.5), STP(Level3)  
Maximum transmission distance : Max. 100m per segment
- UNIT ID: 255

## 5 Extra Communication Equipments.

Protocol Converter (GMPC)

- Converting into RS-232/485/422 common use, Ethernet
- Supporting DNP3.0, MODBUS Protocol



<GMPC>

## 6 Rear View

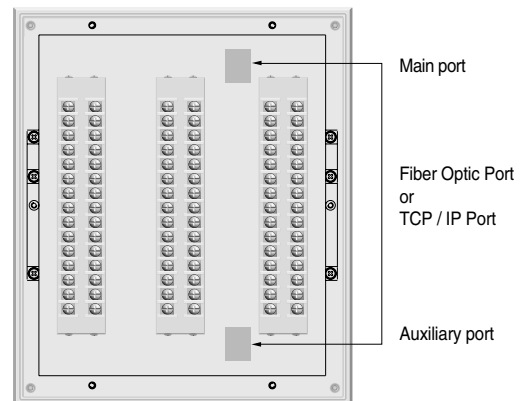

<GIPAM-2000>

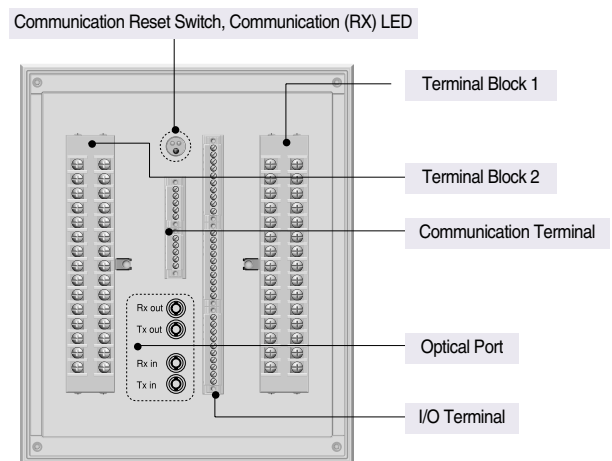

<GIPAM-2200>

# Digital Integrated Protection & Monitoring Device

## External & Structure

### GIPAM-2000

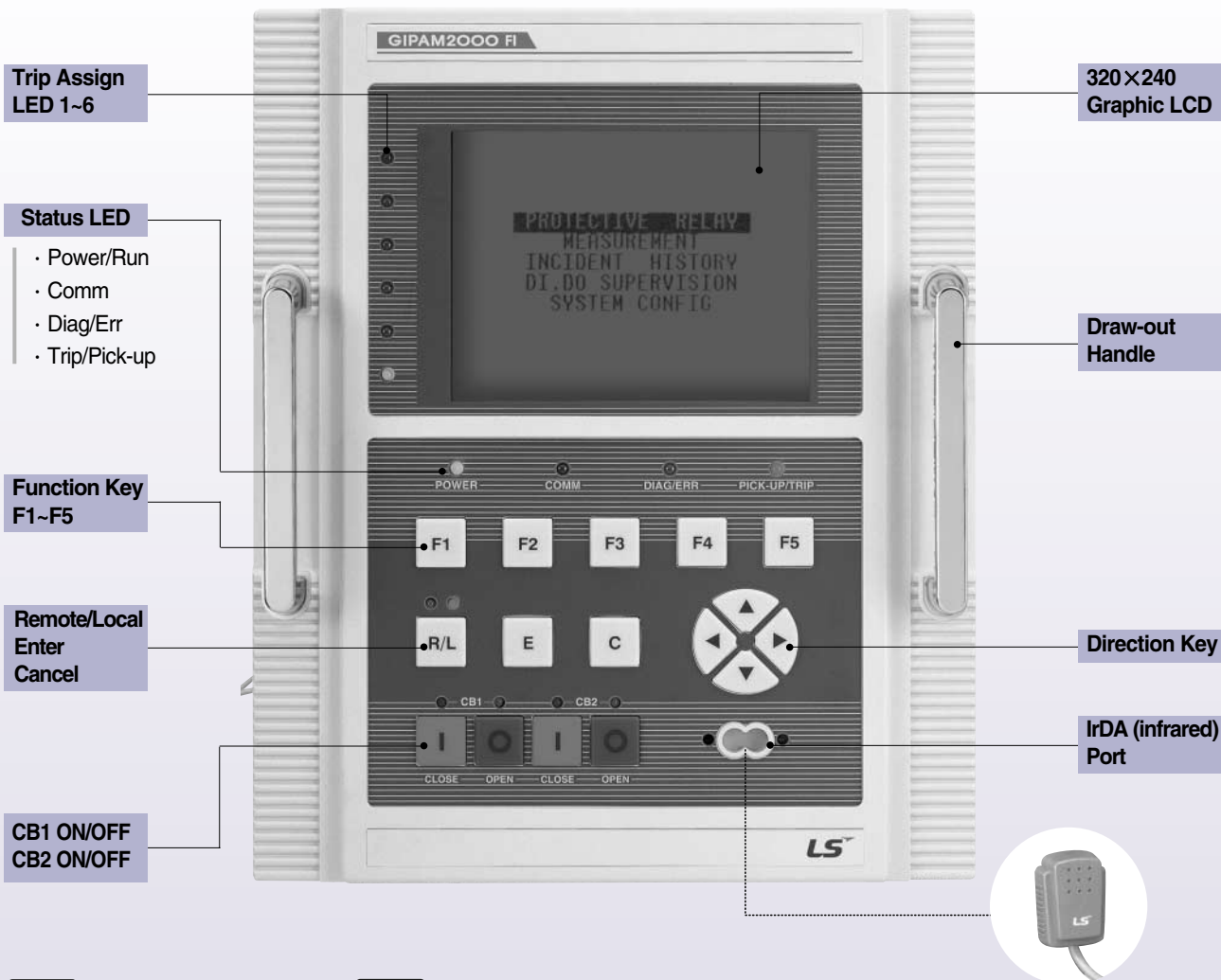

- |   |   |
|---|---|
| <b>F1</b> Display MIMIC Diagram                     | <b>R/L</b> Remote / Local switching<br>(Green LED-Remote, Red LED-Local)                    |
| <b>F2</b> Saving the settings                       | <b>E</b> Enter<br>Selection of items, Confirmation of the settings                          |
| <b>F3</b> Delete recorded data                      | <b>C</b> Cancel<br>Cancellation of the selected item, Cancellation of changing the settings |
| <b>F4</b> Assigning the Trip Assign LED             |   |
| <b>F5</b> Release the Trip / Pick-up status (Reset) |   |



Draw-out Type

# GIPAM-2200

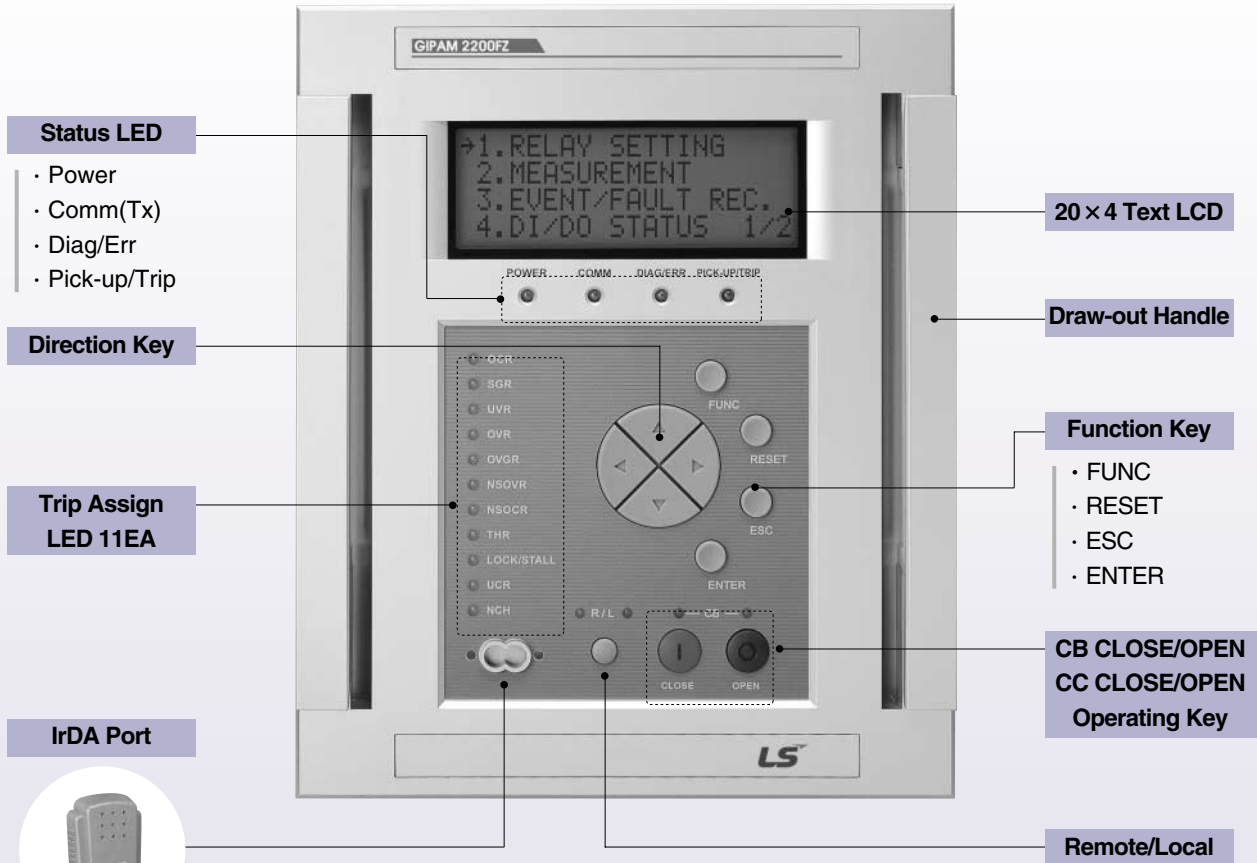

Front View

- FUNC** **FUNCTION**  
Using with ESC key when clearing Data,  
No use of it during normal operation
- RESET** **The Restoration of trip**  
The indication of LED after faults,  
The restoration of LCD
- ESC** **ESC**  
The cancel of selected item &  
change of setting values
- ENTER** **ENTER**  
The selection of item  
The confirmation of setting
- R / L** **Remote/Local**  
The switching of  
Remote/Local



<Draw-out Type>



# Digital Integrated Protection & Monitoring Device

## Man Machine Interface

### GIPAM-2000FI

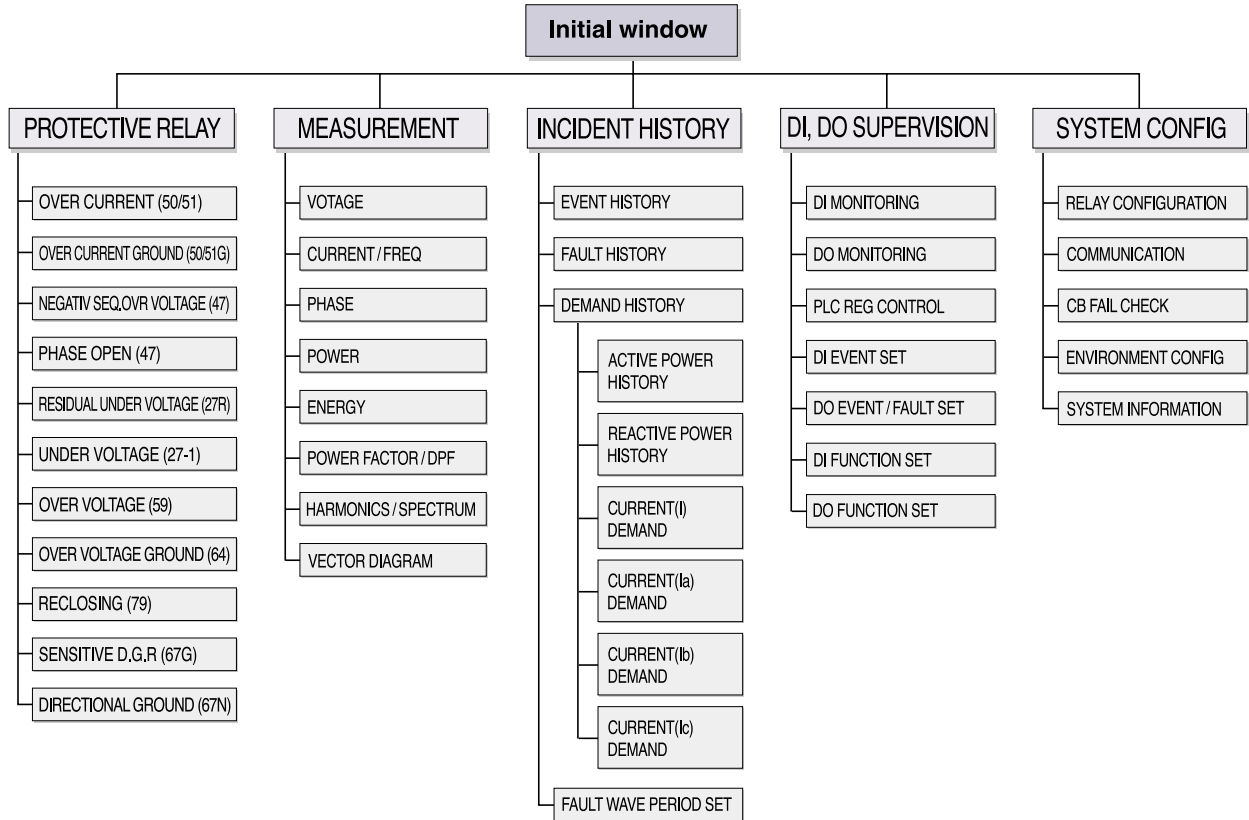

### GIPAM-2000M

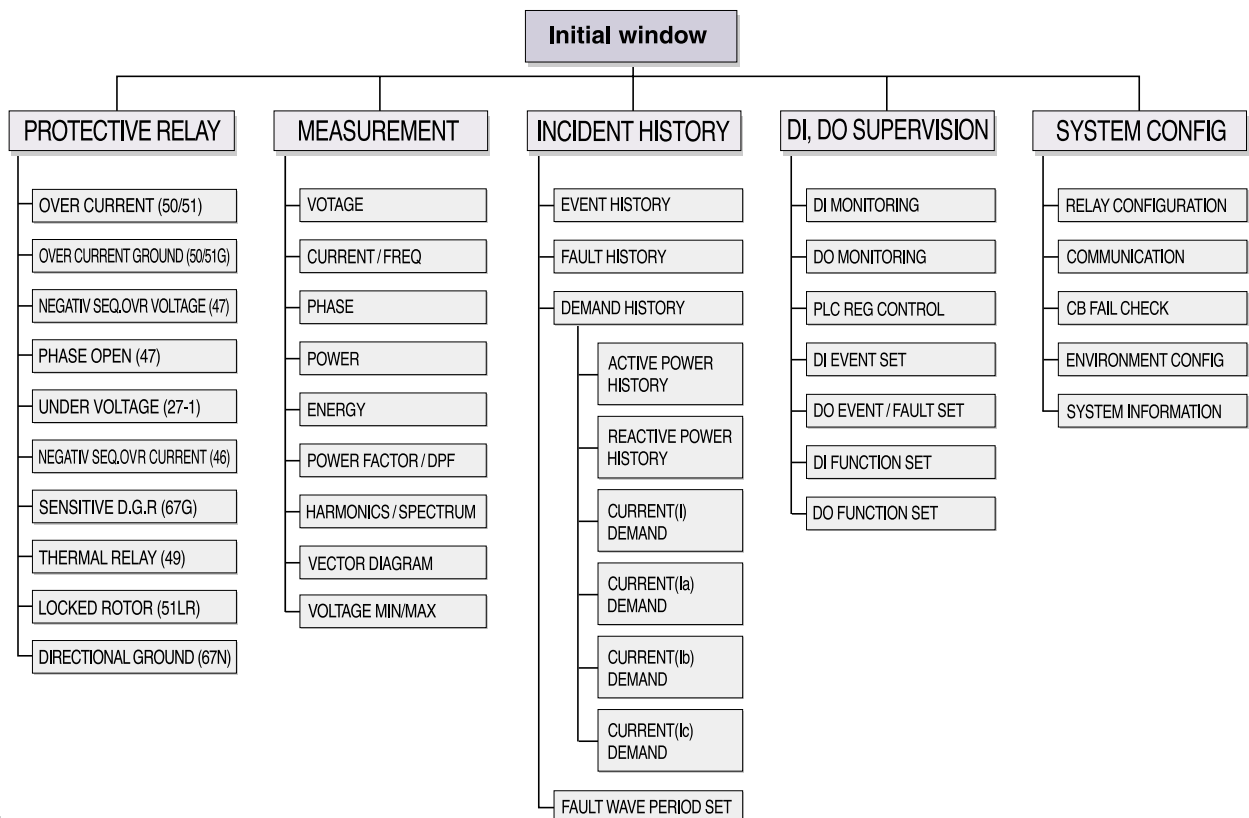

## GIPAM-2000T

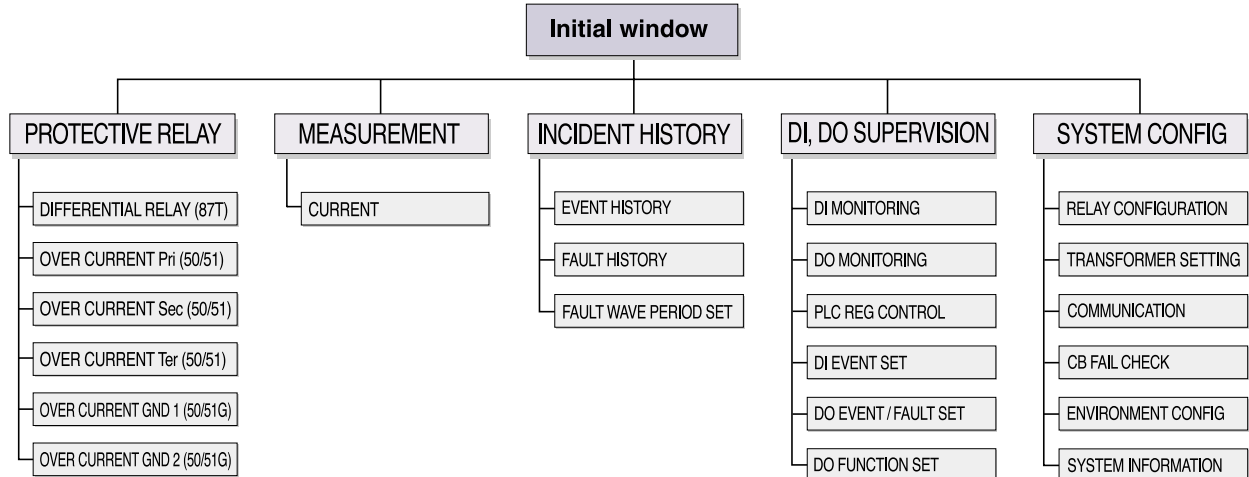

## GIPAM-2200 F

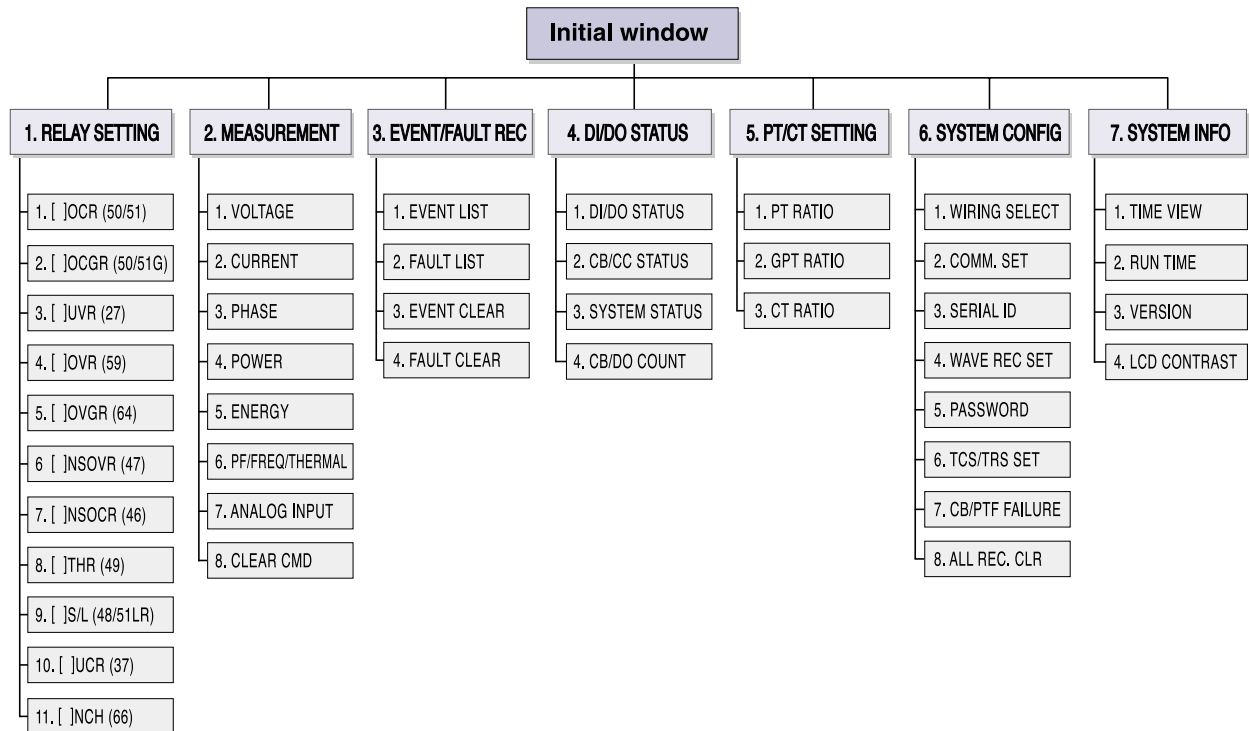

# Digital Integrated Protection & Monitoring Device

## Man Machine Interface

### GIPAM-2200 T

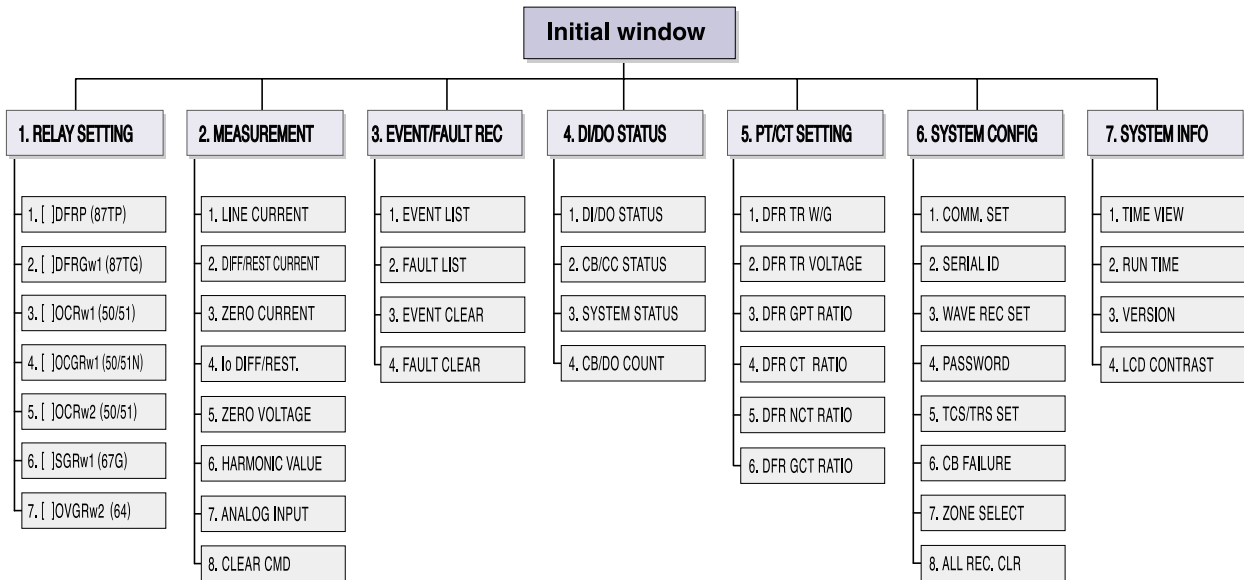

### MMI Interface (GIPAM-2000)

Graphic LCD and control keys on the front of the GIPAM-2000 Series enable the setting of various protection elements.

In addition, various measurements displaying, Fault and Event Data logging, DI / DO Monitoring and the SYSTEM Configuration to check the status of the setting of the GIPAM-2000 can be done.

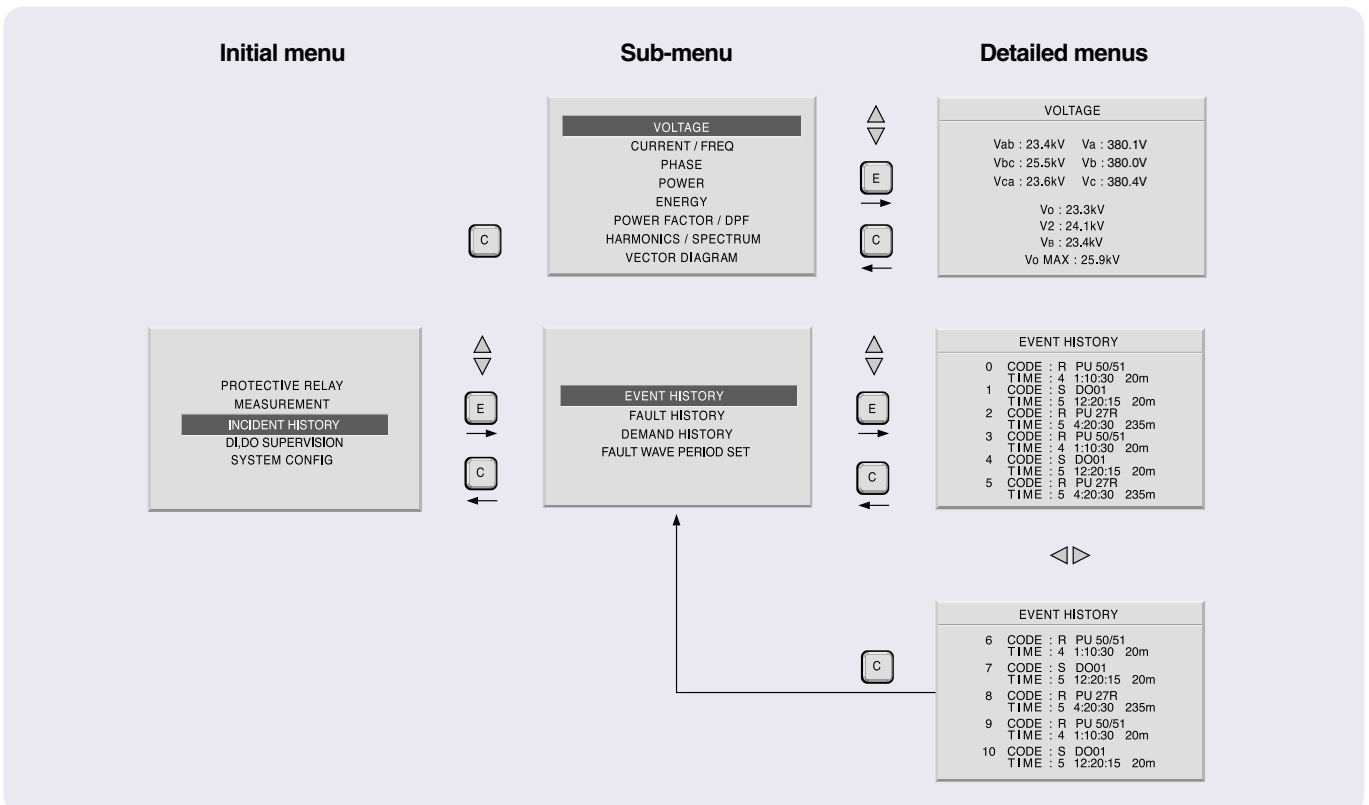

## MMI Interface (GIPAM-2200)

GIPAM-2200 series can be set various kinds of relay functions by handling the Text LCD & Control keys on the front. In the menu, there are measuring value displays, Fault & Event Data Logging, DI/DO Monitoring, SYSTEM Configuration & System information for setting the rate of PT/CT, wiring method, setting communication and verifying information.

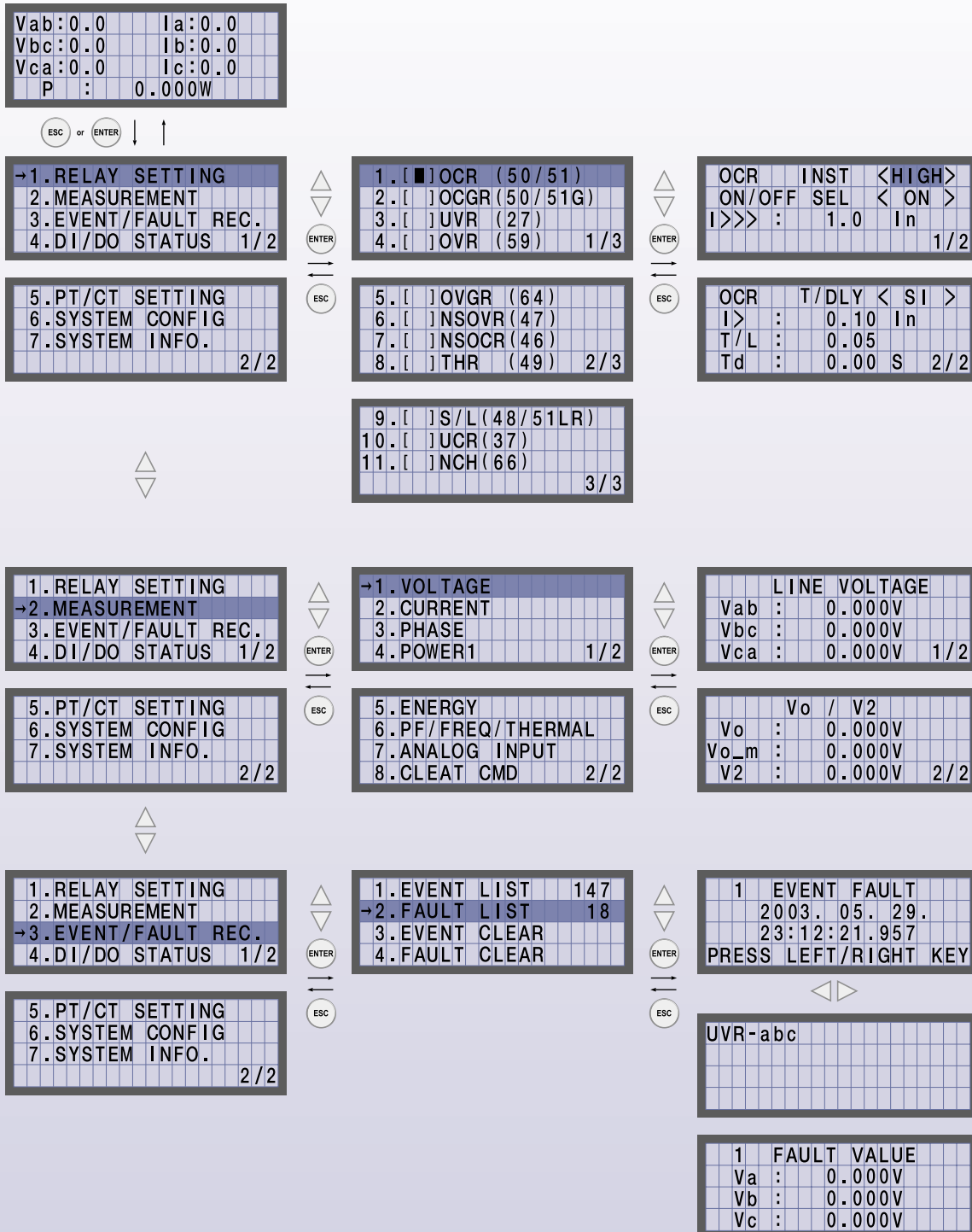

# Digital Integrated Protection & Monitoring Device

## System configuration

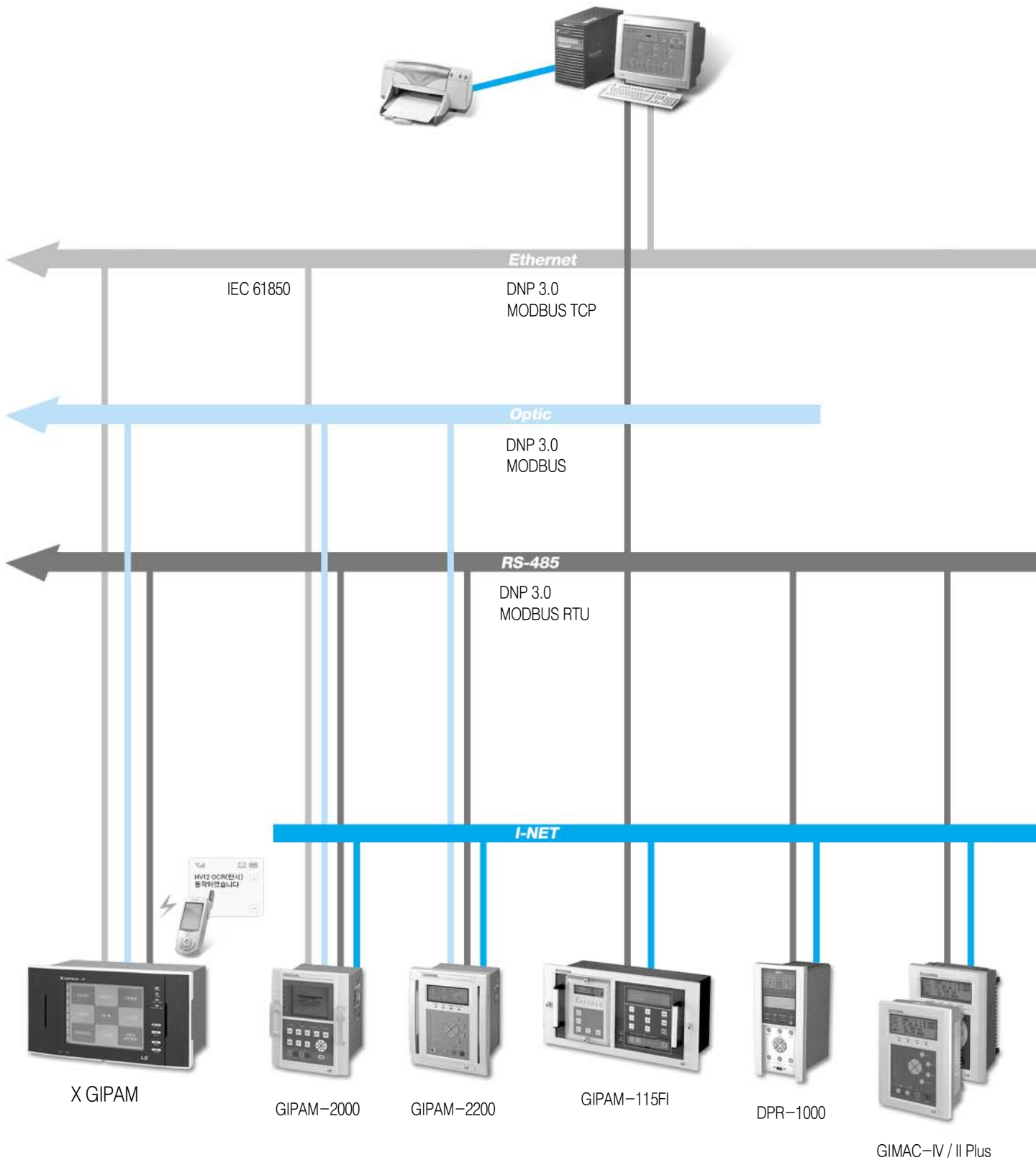

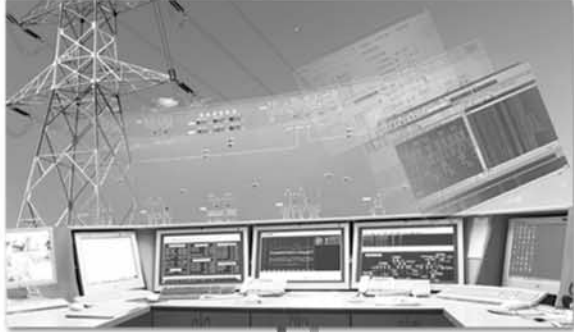

TWS

Internet / Intranet



Web-Server



GMPC-Master



PLC



GMPC-V



GMPC-Master

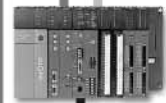

Analog 4-20mA



DPR



micro-RTU



GIMAC-PQ



GIMAC-i



GIMAC-DC



IMP-C



IMC-III

N<sub>1</sub>

GIPAM-2000/2200

# Digital Integrated Protection & Monitoring Device

## Characteristics

### GIPAM-2000FI

Protection	Operating part		Setting range		Operating time		Note
					Setting	Curves	
OCR (50/51)	Instantaneous	Low set	OFF, 0.5~32In/0.1In		30~250ms	Definite	
		High set					
	* Time delay	Low set	OFF, 0.10~5.00In/0.01In		0.05~1.20/0.01	Inverse	
		High set	OFF, 0.10~10.00In/0.01In		0.05~300.00s/0.01s	Definite	
OCGR (50/51N)	Instantaneous	Low set	OFF, 0.1~8.0In/0.02In		40~250ms/5ms	Definite	
		High set					
	* Time delay	Low set	OFF, 0.02~2.00In/0.01In		0.05~1.20/0.01	Inverse	
		High set	OFF, 0.1~2.00In/0.01In		0.05~300.00s/0.01s	Definite	
SGR (67G) DGR (67N)	Time delay	Zero-phases current	Grounded	OFF, 0.9~6mA/0.1mA (Ion=1.5mA)	0.05~10.00s/0.01s	Definite	*If Not use selected at the input of Zero-phase voltage, only ZCT input enables to operate (GR protection element)
			Non-grounded	OFF, 0.02~2.00Ion/0.01Ion (Ion=5A)			
		Zero-phases voltage	8~80V/1V (Von=190V, 190/√3 V)				
		Reference sensitivity Phase angle	0° ~90° /1°				
OVR (59)	* Time delay	Low set	OFF, 0.8~1.6Vn/0.01Vn		0.01~1.20/0.01	Inverse	SI, VI, DT
		High set			0.05~10.00s/0.01s	Definite	
OVGR (64G) <sup>2)</sup>	Instantaneous	OFF, 0.05~0.80Von/0.01Von (0.09~1.0Von/0.01Von)		40~250ms	Definite	SI, VI, EI, DT Von=190V (in case of Von=190/√3 V)	
	Time delay	Low set	OFF, 0.05~0.20Von/0.01Von (0.09~0.4Von/0.01Von)		0.05~1.00/0.01		Inverse
		High set	OFF, 0.05~0.80Von/0.01Von (0.09~1.0Von/0.01Von)		0.05~300.00s/0.01s		Definite
UVR (27)	Time delay	-OFF, 0.20~1.00Vn/0.01Vn		0, 0.05~10.00s/0.01s	Definite		
R-UVR (27R)	Time delay	-OFF, 0.20~1.00Vn/0.01Vn		0, 0.05~10.00s/0.01s	Definite	B-bus R-phase voltage detection	
NSOVR (47N)	Time delay	OFF, 0.05~1.00Vn/0.01Vn		0.05~10.00s/0.01s	Definite	Unbalance (%) = Reverse portion of unbalanced 3-phase circuits Normal portion of unbalanced 3-phase circuits × 100	
POR (47P)	Time delay	OFF, 5~100%/1%		0.05~10.00s/0.01s	Definite	Unbalance (%) = $\frac{V_{max}-V_{min}}{V_{average}} \times 100$	

Reclosing element	Reclosing protective elements	Prepared Time	Dead Time	Reclaim Time	Reclosing times
Reclosing (79)	OCR, OCGR, SGR, DGR	OFF, 0.0~300.0s / 0.1s	0.2~300.0s / 0.1s	0.0~300.0s / 0.1s	1~5 times (1 time for Instantaneous Trip)

Note) 1. \* Operating Delay time (C) can be set: 0.00 ~ 10.00s/0.01s (applies only for inverse time)  
2. OVGR is not connected to the CB\_OFF (TRIP circuit) . ( Modify the LOGIC if necessary )

# GIPAM-2000M

Protection	Operating part		Setting range		Operating time		Note	
					Setting	Curves		
OCR (50/51)	Instantaneous	Low set	OFF, 0.5-32In/0.1In		30~250ms	Definite		
		High set						
	* Time delay	Low set	OFF, 0.10~5.00In/0.01In		0.05~1.20/0.01	Inverse		SI, VI, EI, LI, DT, Kepco SI, Kepco VI
		High set	OFF, 0.10~10.00In/0.01In		0.05~300.00s/0.01s	Definite		
OCGR (50/51N)	Instantaneous	Low set	OFF, 0.1-8.0In/0.02In		40~250ms/5ms	Definite		
		High set						
	* Time delay	Low set	OFF, 0.02~2.00In/0.01In		0.05~1.20/0.01	Inverse		SI, VI, EI, LI, DT, Kepco SI, Kepco VI
		High set	OFF, 0.1~2.00In/0.01In		0.05~300.00s/0.01s	Definite		
SGR (67G) DGR (67N)	Time delay	Zero-phases current	Grounded	OFF, 0.9~6mA/0.1mA (Ion=1.5mA)		0.05~10.00s/0.01s	Definite	*If Not use selected at the input of Zero-phase voltage, only ZCT input enables to operate (GR protection element)
			Non-grounded	OFF, 0.02~2.00In/0.01In (Ion=5A)				
		Zero-phases voltage	8~80V/1V (Von=190V, 190/√3 V)					
		Reference sensitivity Phase angle	0° ~90° /1°					
NSOCR (46)	Instantaneous		OFF, 0.1~2.0In/0.02In		30~250ms/5ms	Definite	SI, VI, EI, LI, DT	
	* Time delay		OFF, 0.08~1.00In/0.01In		0.05~1.00/0.01	Inverse		
					0.05~10.00s/0.01s	Definite		
POR (47P)	Time delay		OFF, 5~100%/1%		40~250ms	Definite	Unbalance (%) = $\frac{V_{max}-V_{min}}{V_{average}} \times 100$	
Stall/Lock (48/51LR)	Time	Stall Current	OFF, 0.20~10.00In/0.01In		0.05~300.00s/0.01s	Definite	Starting time set 1~300s/0.1s	
		Lock Current	OFF, 0.20~10.00In/0.01In		0.05~1.00/0.01	Inverse (VI,EI)		
THR (49)	Hot		OFF, 0.20~5.0In/0.01In		Thermal time constant 0.5~60min/0.5min	$t = \tau \cdot \ln \frac{I^2 - I_p^2}{I^2 - (k \cdot I_B)^2}$	t : Operating time k : multiple factor (0.5~1.5/0.05) τ : Thermal time constant	
	Cold					$t = \tau \cdot \ln \frac{I^2}{I^2 - (k \cdot I_B)^2}$		
NSOVR (47N)	Time delay		OFF, 0.05~1.00Vn/0.01Vn		0.05~10.00s/0.01s	Definite	Unbalance (%) = $\frac{\text{Reverse portion of unbalanced 3-phase circuits}}{\text{Normal portion of unbalanced 3-phase circuits}} \times 100$	
UVR (27)	Time delay		-OFF, 0.20~1.00Vn/0.01Vn		0, 0.05~10.00s/0.01s	Definite		

\* Operating Delay time (C) can be set: 0.00 ~ 10.00s/0.01s (applies only for inverse time)

# Digital Integrated Protection & Monitoring Device

## Characteristics

### GIPAM-2000T

Protection	Setting range		Delay time	Note
* DFR (87T)	Low set	Id : 0.2~1.0In/0.1In Slope 1 : 0.15~1.00/0.01 Slope 2 : 0.15~1.00/0.01 Knee Point : 1.0~20.0In/0.1In	Inst., 0.05~10.00s/0.01s	Inst.: less than 50ms
		Inrush Inhibit : 5~50%/1%	Inrush Inhibit : 0.02~60.00/0.01s	
	High set	Id : 2.0~32In/0.1In	Instantaneous: less than 40ms	

Protection	Time		Setting range	Delay time		Note	
				Setting	Curves		
OCR (50/51-1)	Instantaneous	Low set	OFF, 0.5~32In/0.1In	30~250ms/5ms	Definite		
		High set					
	* Time delay	Low set	OFF, 0.10~5.00In/0.01In	0.05~1.20/0.01	Inverse		SI, VI, EI, LI, DT, Kepco SI, Kepco VI
		High set	OFF, 0.10~10.00In/0.01In	0.05~300.00s/0.01s	Definite		
OCR (50/51-2)	Instantaneous	Low set	OFF, 0.5~32In/0.01In	30~250ms/5ms	Definite		
		High set					
	* Time delay	Low set	OFF, 0.10~5.00In/0.01In	0.05~1.20/0.01	Inverse		SI, VI, EI, LI, DT, Kepco SI, Kepco VI
		High set	OFF, 0.10~10.00In/0.01In	0.05~300.00s/0.01s	Definite		
OCR (50/51-3)	Instantaneous	Low set	OFF, 0.5~32In/0.01In	30~250ms/5ms	Definite		
		High set					
	* Time delay	Low set	OFF, 0.10~5.00In/0.01In	0.05~1.20/0.01	Inverse		SI, VI, EI, LI, DT, Kepco SI, Kepco VI
		High set	OFF, 0.10~10.00In/0.01In	0.05~300.00s/0.01s	Definite		
OCGR (50/51N-1)	Instantaneous	Low set	OFF, 0.1~8.0In/0.02In	40~250ms	Definite		
		High set					
	* Time delay	Low set	OFF, 0.02~2.00In/0.01In	0.05~1.20/0.01	Inverse		SI, VI, EI, LI, DT, Kepco SI, Kepco VI
		High set	OFF, 0.1~2.00In/0.01In	0.05~300.00s/0.01s	Definite		
OCGR (50/51N-2)	Instantaneous	Low set	OFF, 0.1~8.0In/0.02In	40~250ms	Definite		
		High set					
	* Time delay	Low set	OFF, 0.02~2.00In/0.01In	0.05~1.20/0.01	Inverse		SI, VI, EI, LI, DT, Kepco SI, Kepco VI
		High set	OFF, 0.1~2.00In/0.01In	0.05~300.00s/0.01s	Definite		

Note) 1.\*Operating Delay time (C) can be set: 0.00 ~ 10.00s/0.01s (applies only for inverse time)  
2. OCR(50/51-3) and OCGR(50/51N-2) are models for three winding.

# GIPAM-2200 F

Protection	Operating part		Setting range		Operating time		Note	
					Setting	Curves		
OCR (50/51)	Instantaneous	Low set	OFF, 1.0~32.0In/0.1In		Low: 0.05~300.00s/0.01s High: 40ms and below	Definite		
		High set						
	Time delay		OFF, 0.10~10.00In/0.01In		0.05~1.20/0.01 0.05~300.00s/0.01s	Inverse Definite	DT, SI, VI, EI, LI	
OCGR (50/51N)	Instantaneous	Low set	OFF, 0.1~8.0In/0.02In		Low: 0.05~300.00s/0.01s High: 40ms and below	Definite		
		High set						
	Time delay		OFF, 0.02~2.00In/0.01In		0.05~1.20/0.01 0.05~300.00s/0.01s	Inverse Definite	DT, SI, VI, EI, LI	
NSOVR POR (47)	Time delay	Low set	OFF, 0.1~1.0Vn/0.1Vn		0.05~10.00s/0.01s	Definite	V2=1/3 (VR + a²VS + aVT) a=1 ∠ 120°, a²=1 ∠ 240°	
		High set						
UVR (27)	Time delay		0.20~1.00Vn/0.01Vn		0, 0.05~10.00s/0.01s	Definite		
OVR (59)	Time delay	Low set	OFF, 0.8~1.6Vn/0.01Vn		0.05~10.00s/0.01s	Definite		
		High set						
OVGR (64)	Instantaneous		OFF, 11~80V/1V		Inst, 50~250ms/5ms	Definite	DT, SI Von=190V or 190/√3V	
	Time delay		OFF, 11~80V/1V		0.05~1.00/0.01 0.05~300.00s/0.01s	Inverse Definite		
NSOCR (46)	Instantaneous		OFF, 0.1~1.0In/0.02In		Inst, 50~250ms/5ms	Definite	DT, SI, VI, EI, LI	
	Time delay		OFF, 0.1~1.0In/0.01In		0.05~1.00/0.01 0.05~10.00s/0.01s	Inverse Definite	Inst : 40ms and below	
SGR (67G) DGR (67N)	Time delay	Zero-phase current	isolated system	0.9~6mA/0.1mA (Ion=1.5mA)	0.05~10.00s/0.01s	Definite	Vo > Vos Io > Ios ∅ (Vo) - ∅ (Io) ≤ RCA + 87° ∅ (Vo) - ∅ (Io) ≥ RCA - 87°	
			grounded system	0.02~2.00Ion/0.01Ion (Ion=5A)				
		Zero-phase voltage		11~80V/1V (Von=190V, 190/√3V)				
		Relay characteristic angle		0° ~90° /5°				
THR (49)	Hot		0.2~1.2In/0.01In		τh : 2.0~60.0min/0.5min	t = τh · ln [ (I² - IP²) / (I² - (k · IB)²) ]	t : operating time k : multiple factor (0.8~1.2/0.05) τ : thermal constant	
	Cold				τc : 2.0~60.0min/0.5min			t = τc · ln [ I² / (I² - (k · IB)²) ]
Stall/Lock (48/51LR)	Time delay	Stall	OFF, 0.2~10.0In/0.01In		0.05~300.00s/0.01s	Definite	Start time range 1.0~300.0s/0.1s	
		Lock	OFF, 0.2~10.0In/0.01In		0.05~1.00/0.01 0.05~300.00s/0.01s	Inverse (VI, EI) Definite		
UCR (37)	Time delay		0.1~0.9In/0.02In		0.1~10.0s/0.01s	Definite		
NCH (66)	Starts Number				1~5 times/1			
	Base Time				10~60min/1min			
	Time between starts Block				0~60min/1min			
	Restart Block				0~60min/1min			
	Residual Thermal				10~80%/1%			

# Digital Integrated Protection & Monitoring Device

## Characteristics

### GIPAM-2200 T

Protection	Setting range		Operating time	Note
DFR (87T-P)	Time delay differential current (Low set)	Id (Pick-up): 0.2~1.0In/0.1In Slope 1: 15~100%/1% Slope 2: 15~100%/1% Knee Point: 1.0~20.0In/0.1 In	Inst, 0.05~10.00s/0.01s	Normal mode Inst : 40ms and below Inrush mode Inst : 50ms and below
		Inrush Inhibit: ON (10~50%/1%) OFF		2Harmonic/Basic
	Instantaneous differential current (High set)	Id (Pick-up): 2.0~32.0 In/0.1In	40ms and below	Inrush Inhibit
Io Elimination: ON, OFF				
DFR (87T-G)	Zero-phase differential current	Iod (Pick-up): 0.05~1.00In/0.01In Slope: 15~100%/1%	Inst, 0.05~10.00s/0.01s	Inst : 40ms and below

Protection	Operating part		Setting range	Operating time *		Note
				Setting	Curves	
OCR-1 (50/51)	Instantaneous	Low set	OFF, 1.0~32.0In/0.1In	Low: 0.05~300.00s/0.01s High: 40ms and below	Definite	
		High set				
OCR-2 (50/51)	Instantaneous	Low set	OFF, 1.0~32.0In/0.1In	Low: 0.05~300.00s/0.01s High: 40ms and below	Definite	
		High set				
OCGR-1 (50/51N)	Instantaneous	Low set	OFF, 0.1~8.0In/0.02In	Low: 0.05~300.00s/0.01s High: 40ms and below	Definite	
		High set				
OCGR-2 (50/51N)	Instantaneous	Low set	OFF, 0.1~8.0In/0.02In	Low: 0.05~300.00s/0.01s High: 40ms and below	Definite	
		High set				
OVGR (64) <sup>2)</sup>	Time delay	Zero-phase voltage	11~80V/1V (Von=190V, 190/√3V)	Inst, 50~250ms/5ms	Definite	DT, SI
		Relay characteristic angle	0° ~90°/5°	0.05~1.00/0.01 0.05~300.00s/0.01s	Inverse Definite	Von=190V or 190/√3V
SGR (67G) DGR (67N)	Time delay	Zero-phase current	isolated system OFF, 0.9~6mA/0.1mA (Ion=1.5mA) grounded system OFF, 0.02~2.0In/0.01In (Ion=5A)	0.05~10.00s/0.01s	Definite	Vo > Vos Io > Ios ∅ (Vo) - ∅ (Io) ≤ RCA + 87° ∅ (Vo) - ∅ (Io) ≥ RCA - 87°
	Zero-phase voltage	11~80V/1V (Von=190V, 190/√3V)				

Note) 1. \* Operating Delay time (C) can be set: 0.00 ~ 10.00s/0.01s (applies only for inverse time)  
2. OVGR is not connected to the CB\_OFF (TRIP circuit) . ( Modify the LOGIC if necessary )

# Time Characteristic Curves

## Standard Inverse Time-SI

Operating time(t)

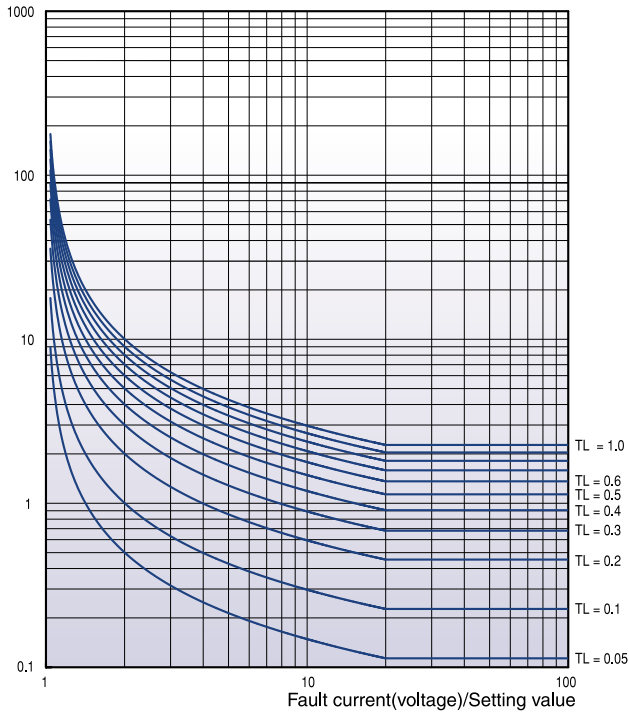

- **Application : OCR (50/51)**  
**OCGR (50/51N)**  
**OVGR (64)**  
**NSOCR (46)**

$$t = \frac{0.14}{(I/I_s)^{0.02-1}} \times TL + C$$

- Time lever (TL) : 0.05~1.2  
 ( OVGR  
 NSOCR } TL: 0.05~1.0 )

• Relay constant C: 0

• Operation Delay Time: 0.00~10.00s/0.01s  
 (OCR, OCGR, NSOCR)

## Very Inverse Time-VI

Operating time(t)

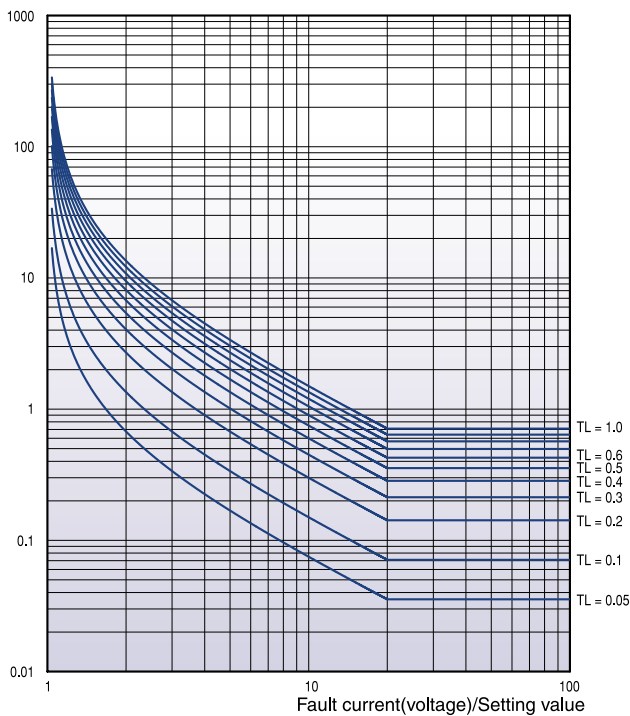

- **Application : OCR (50/51)**  
**OCGR (50/51N)**  
**OVGR (64)**  
**NSOCR (46)**  
**Locked Rotor (51LR)**

$$t = \frac{13.5}{(I/I_s)-1} \times TL + C$$

- Time lever (TL) : 0.05~1.2  
 ( OVGR  
 NSOCR  
 Locked Rotor } TL: 0.05~1.0 )

• Relay constant C: 0

• Operation Delay Time: 0.00~10.00s/0.01s  
 (OCR, OCGR, NSOCR)

# Digital Integrated Protection & Monitoring Device

## Time Characteristic Curves

### Extremely Inverse Time-EI

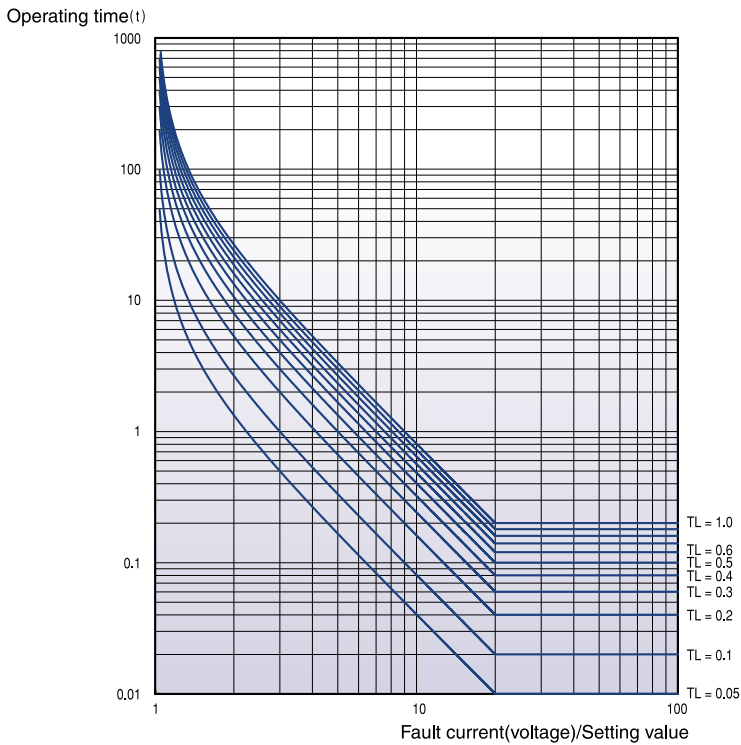

- Application : OCR (50/51)  
OCGR (50/51N)  
OVGR (64)  
NSOCR (46)  
Locked Rotor (51LR)

$$t = \frac{80}{(I/I_s)^2 - 1} \times TL + C$$

- Time lever (TL) : 0.05~1.2  

}	OVGR	TL: 0.05~1.0
	NSOCR	
	Locked Rotor	
- Relay constant C: 0
- Operation Delay Time: 0.00~10.00s/0.01s  
(OCR, OCGR, NSOCR)

### Long Inverse Time-LI

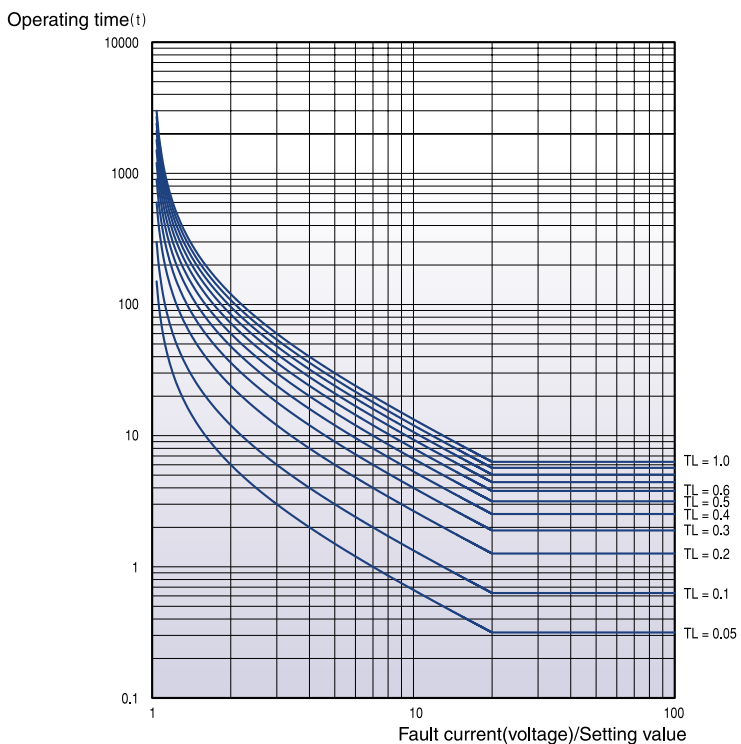

- Application : OCR (50/51)  
OCGR (50/51N)  
NSOCR (46)

$$t = \frac{120}{(I/I_s) - 1} \times TL + C$$

- Time lever TL: 0.05~1.2  
(NSOCR (TL): 0.05~1.0)
- Relay constant C: 0
- Operation Delay Time: 0.00~10.00s/0.01s  
(NSOCR)

# Thermal Curve

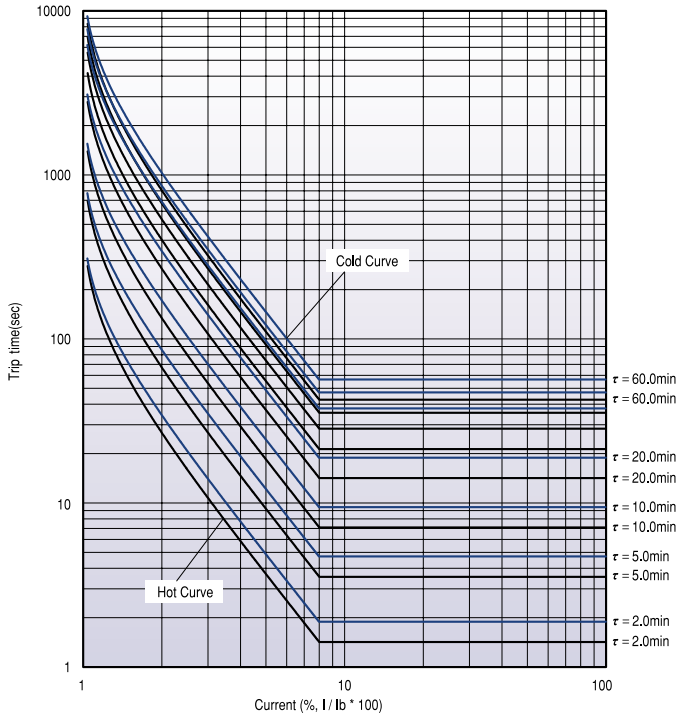

### • Application : THR (49)

**HOT** 
$$t = \tau_h \cdot \ln \frac{I^2 - I_P^2}{I^2 - (k \cdot I_B)^2}$$
  

$$\tau_h = 2.0 \sim 60.0 \text{min}$$

**COLD** 
$$t = \tau_c \cdot \ln \frac{I^2}{I^2 - (k \cdot I_B)^2}$$
  

$$\tau_c = 2.0 \sim 60.0 \text{min}$$
  

$$\left( \begin{array}{l} I_P = 0.5 \\ k = 1 \\ I_B = 1 \end{array} \right)$$

- $I_P$  : Fault full load current
- $I_B$  : Rating load current
- $k$  : Overload constant
- $I$  : Fault current
- $\tau_h$  ( $\tau$  heating)
- $\tau_c$  ( $\tau$  cooling)

### • Application : SGR (67G) DGR(67N)

- (a) Pick-up  $I_o \angle$  :  
323° ~ 127°
- (b) Drop-out  $I_o \angle$  :  
137° ~ 313°

$V_o > V_{os}$   
 $I_o > I_{os}$   
 $RCA - 87^\circ \leq \phi(V_o) - \phi(I_o) \leq RCA + 87^\circ$

• RCA : Relay Characteristic Angle

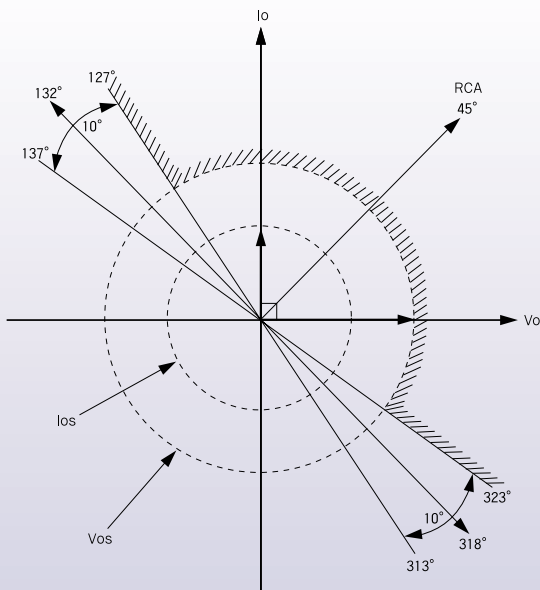

### Ratio Differential Curve

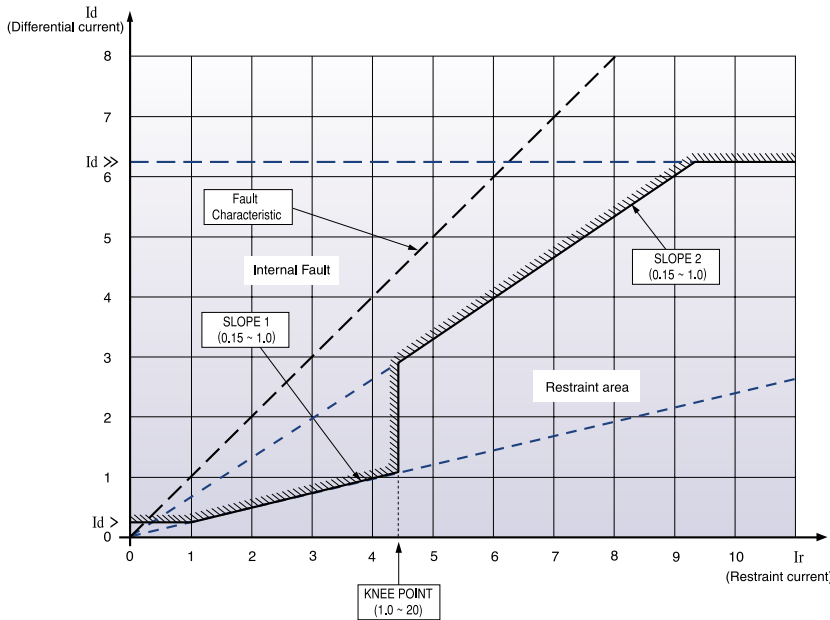

#### • Application : DFR (87T-P)

$$I_d = I_{\text{differential}} = |\bar{I}_1 - \bar{I}_2| \text{ (Vector sum.)}$$

$$I_r = I_{\text{restraint}} = |I_1| + |I_2| \text{ (Scalar sum.)}$$

$$\text{SLOPE} = \left[ \frac{I_d}{I_r} \right]$$

Fault Characteristic : ( $I_{1st} = I_f$ ,  $I_{2nd} = 0$ )

$I_d$ : Differential current

$I_r$ : Restraining current

$I_d >$  : Time delay differential current  
(Low set: 0.2~1.0)

$I_d >>$ : Instantaneous differential current  
(High set: 2.0~32.0)

### Ground Ratio Differential Curve

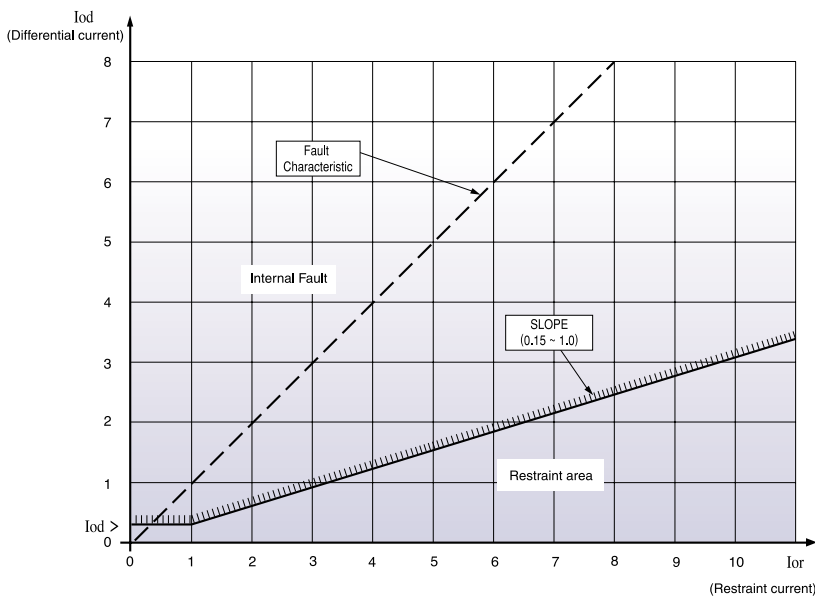

#### • Application : DFR (87T-G)

$$I_{od} = |3\bar{I}_o - \bar{I}_g| \text{ (Vector sum.)}$$

$$I_{or} = |3\bar{I}_o| + |\bar{I}_g| \text{ (Scalar sum.)}$$

$$\text{SLOPE} = \left[ \frac{I_{od}}{I_{or}} \right]$$

Fault Characteristic ( $I_{1st} = I_f$ ,  $I_{2nd} = 0$ )

$I_{od}$ : Zero-phase differential current

$I_{or}$ : Zero-phase restraining current

$I_{od >}$ : Time delay zero-phase differential current (0.05 ~ 1.00)

# Wirings

## GIPAM-2000FI/M (3P3W)

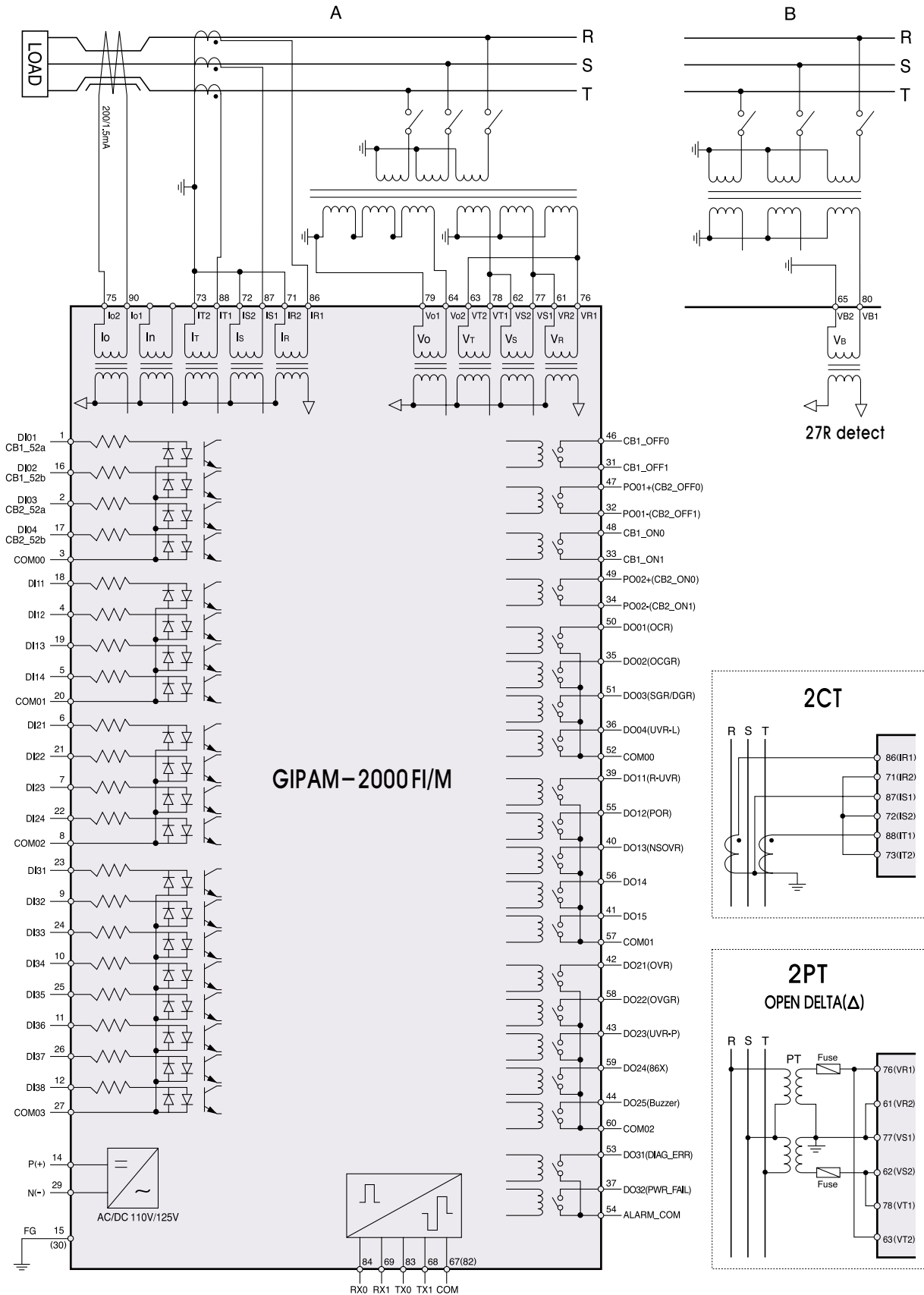

GIPAM-2000FI/M

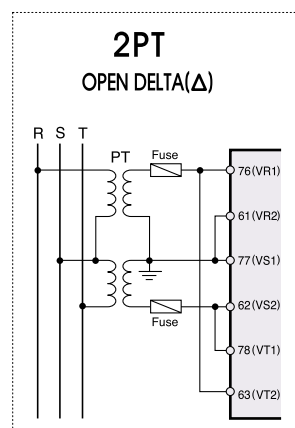
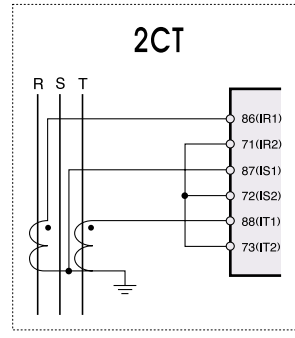

N<sub>1</sub>  
GIPAM-2000/2200

# Digital Integrated Protection & Monitoring Device

## Wirings

### GIPAM-2000FI/M (3P4W)

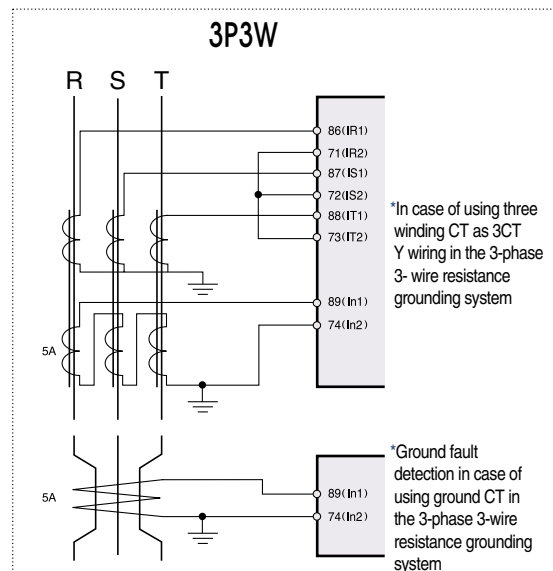
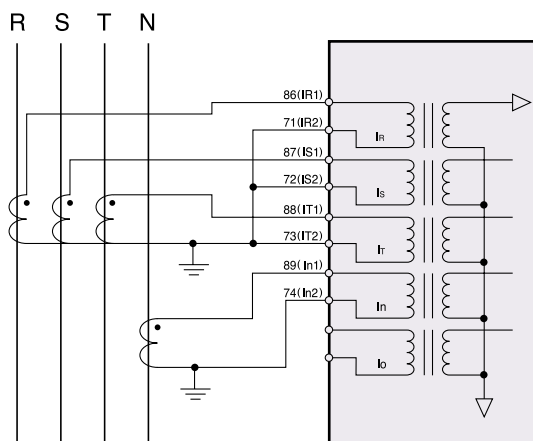
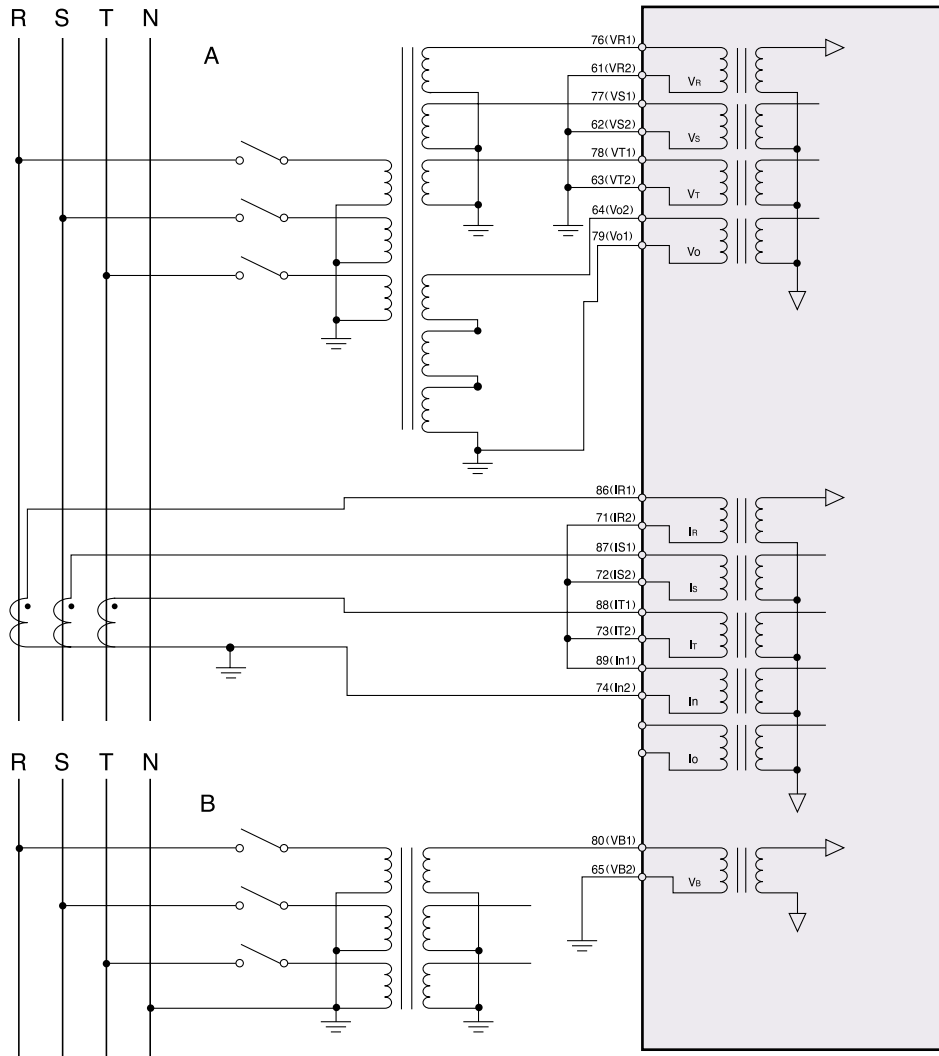

\* In case of using a separate CT for the neutral point

# GIPAM-2000T (for two winding)

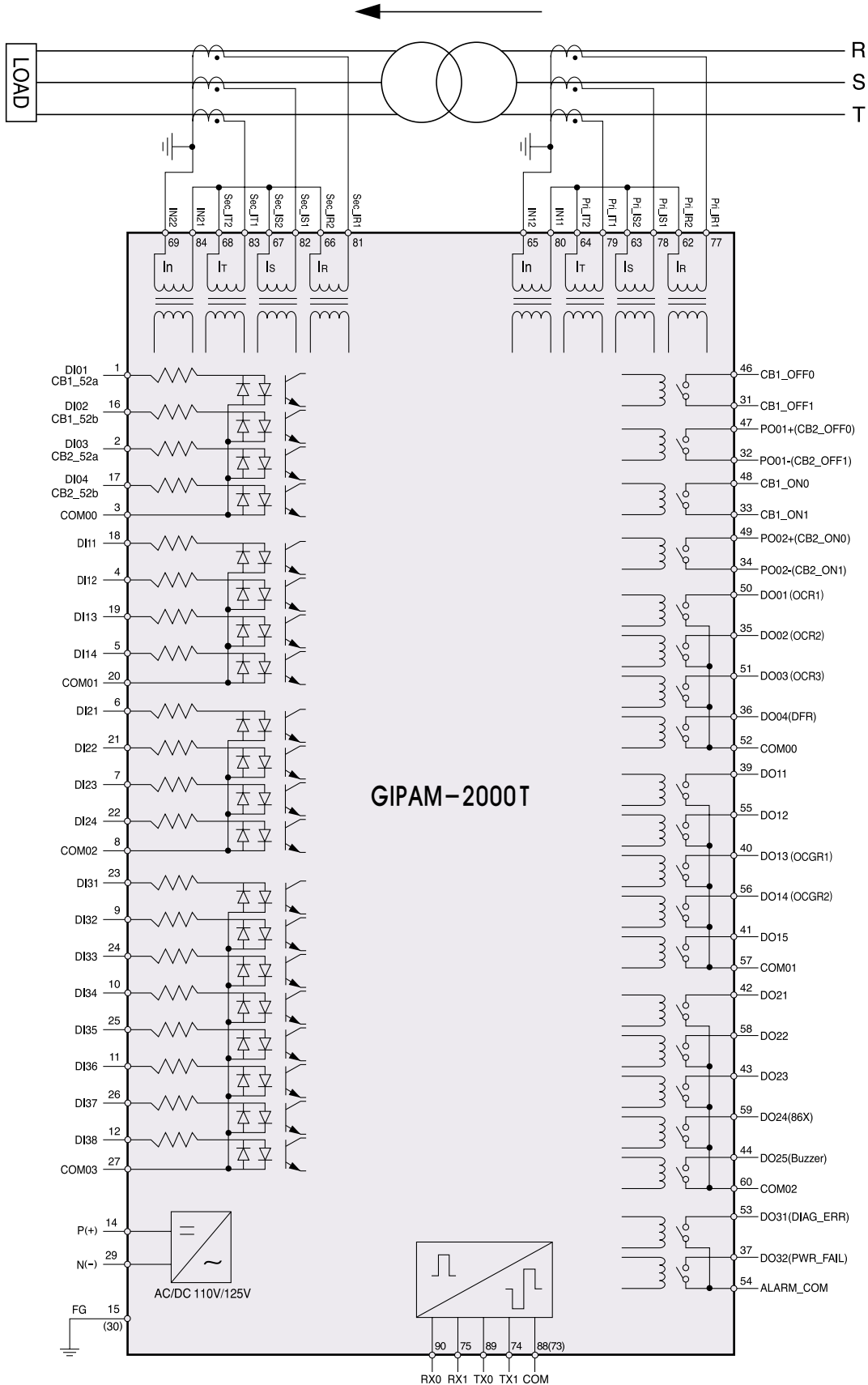

**N<sub>1</sub>**  
GIPAM-2000/2200

# Digital Integrated Protection & Monitoring Device

## Wirings

### GIPAM-2000T (for three winding)

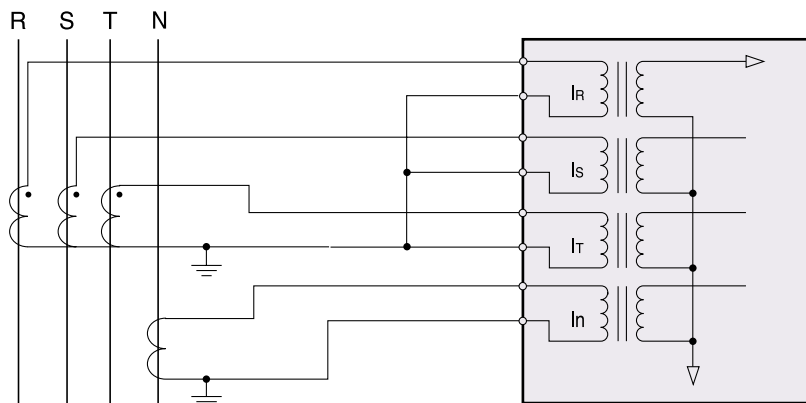
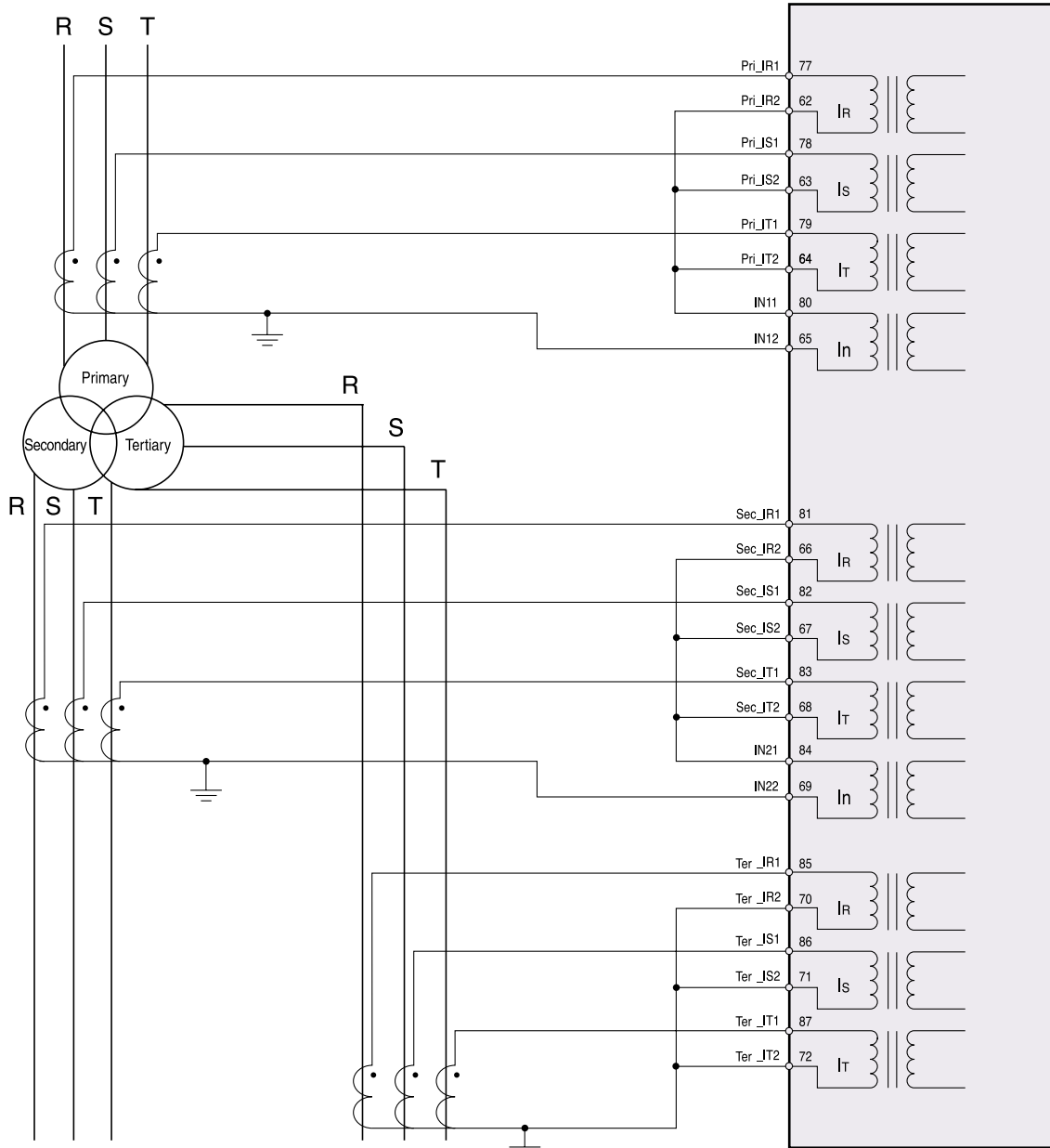

\* In case of using a separate CT for the neutral point (primary, secondary and tertiary all possible)

# GIPAM-2200FN/FZ (3P3W)

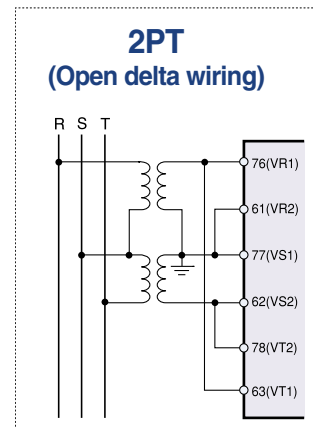
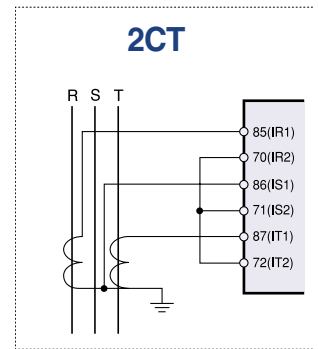
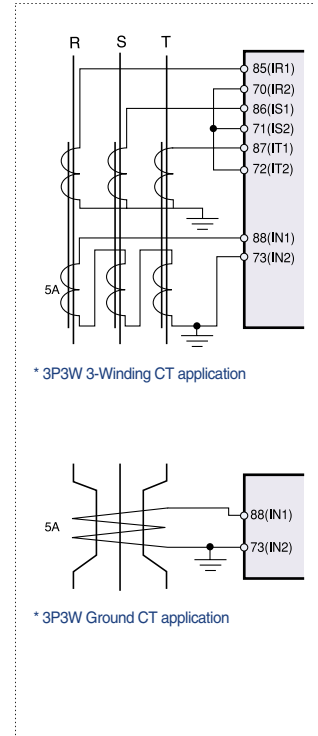
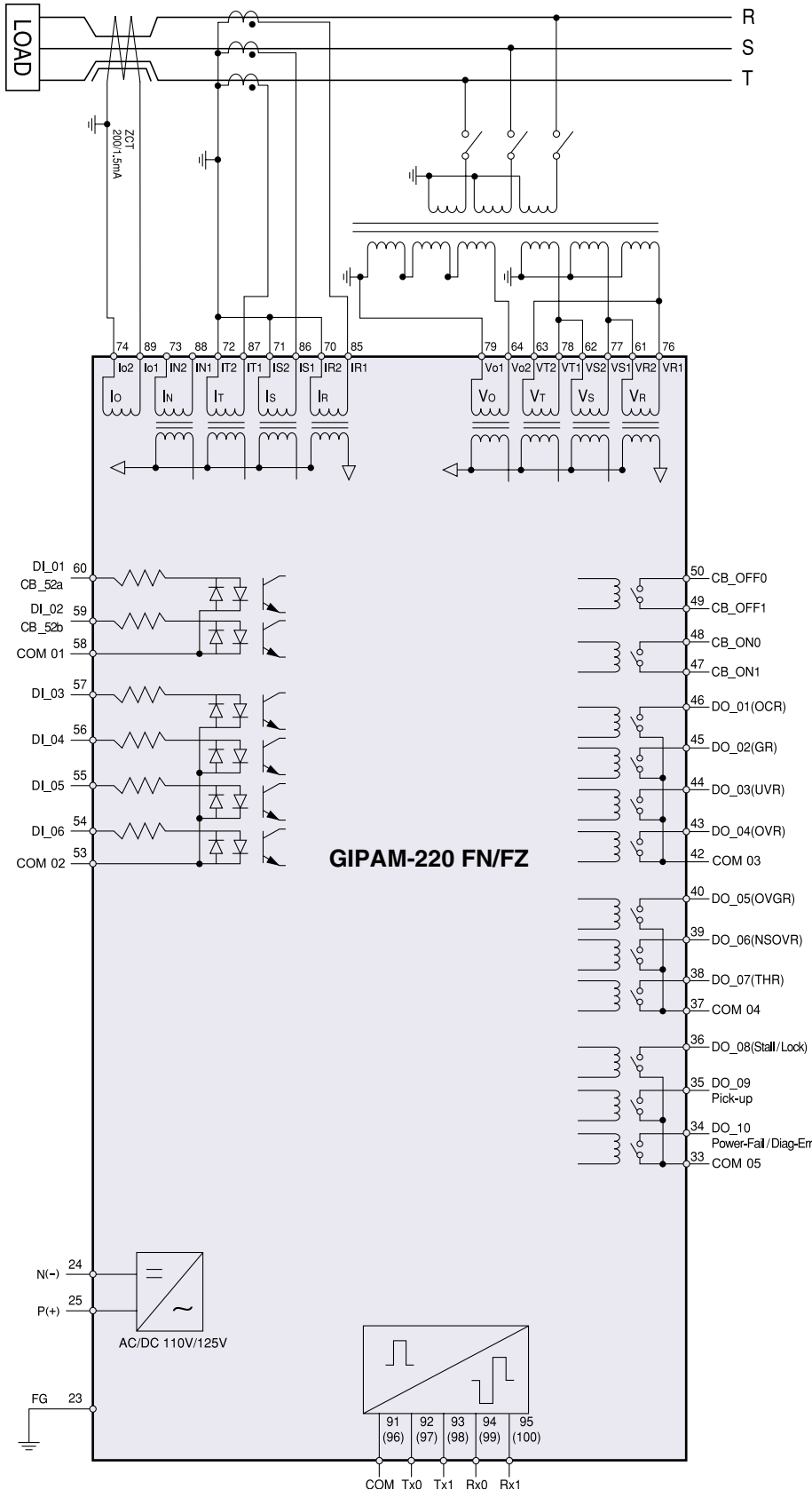

**N<sub>1</sub>**  
GIPAM-2000/2200

# Digital Integrated Protection & Monitoring Device

## Wirings

### GIPAM-2200FN (3P4W)

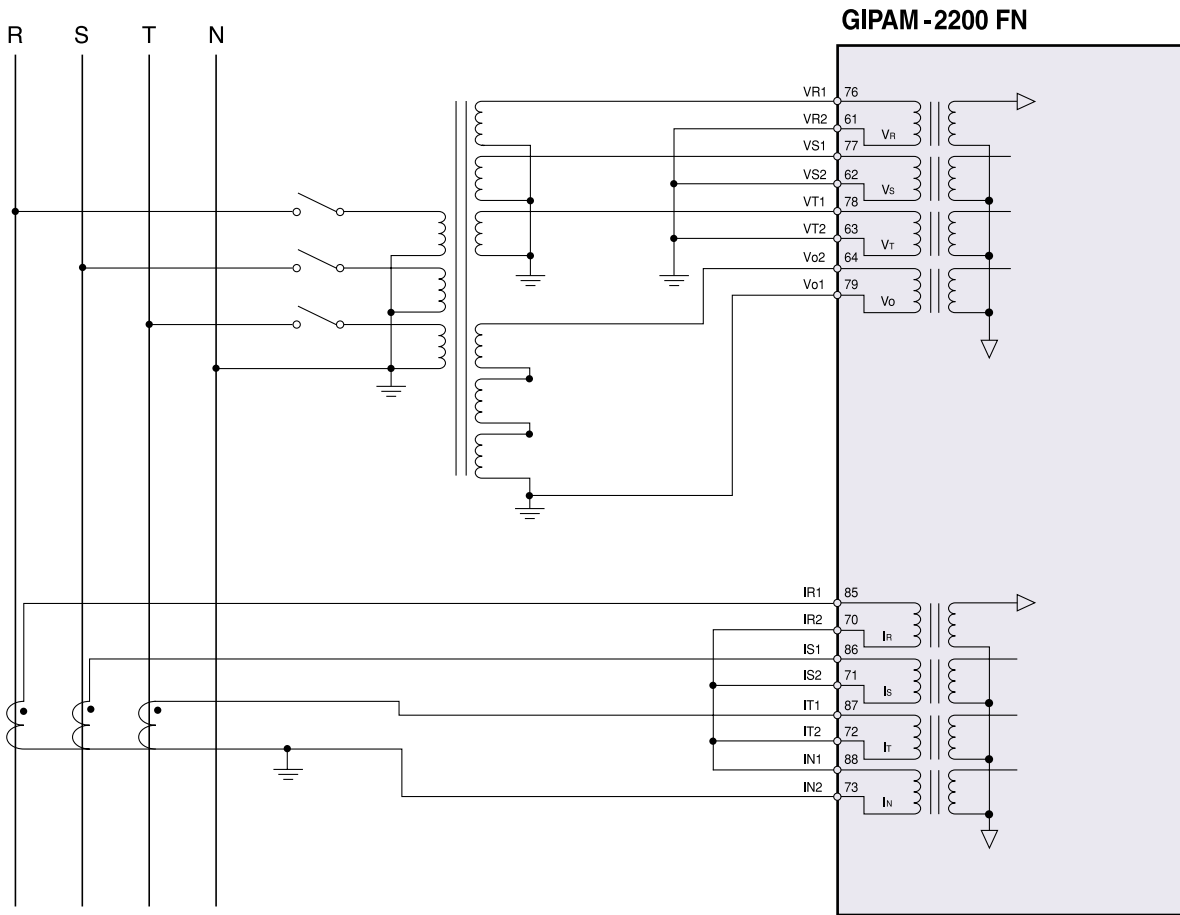

### 1P3W

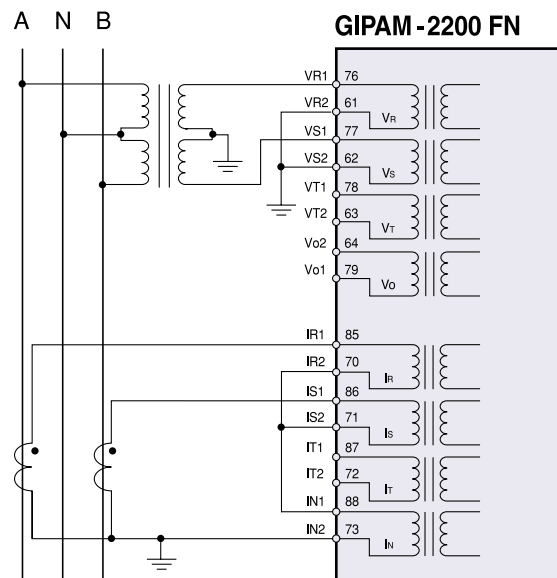
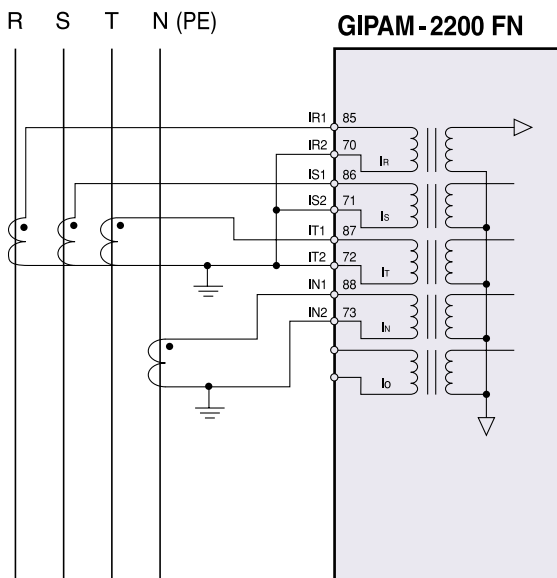

\* NCT application

# GIPAM-2200 T1

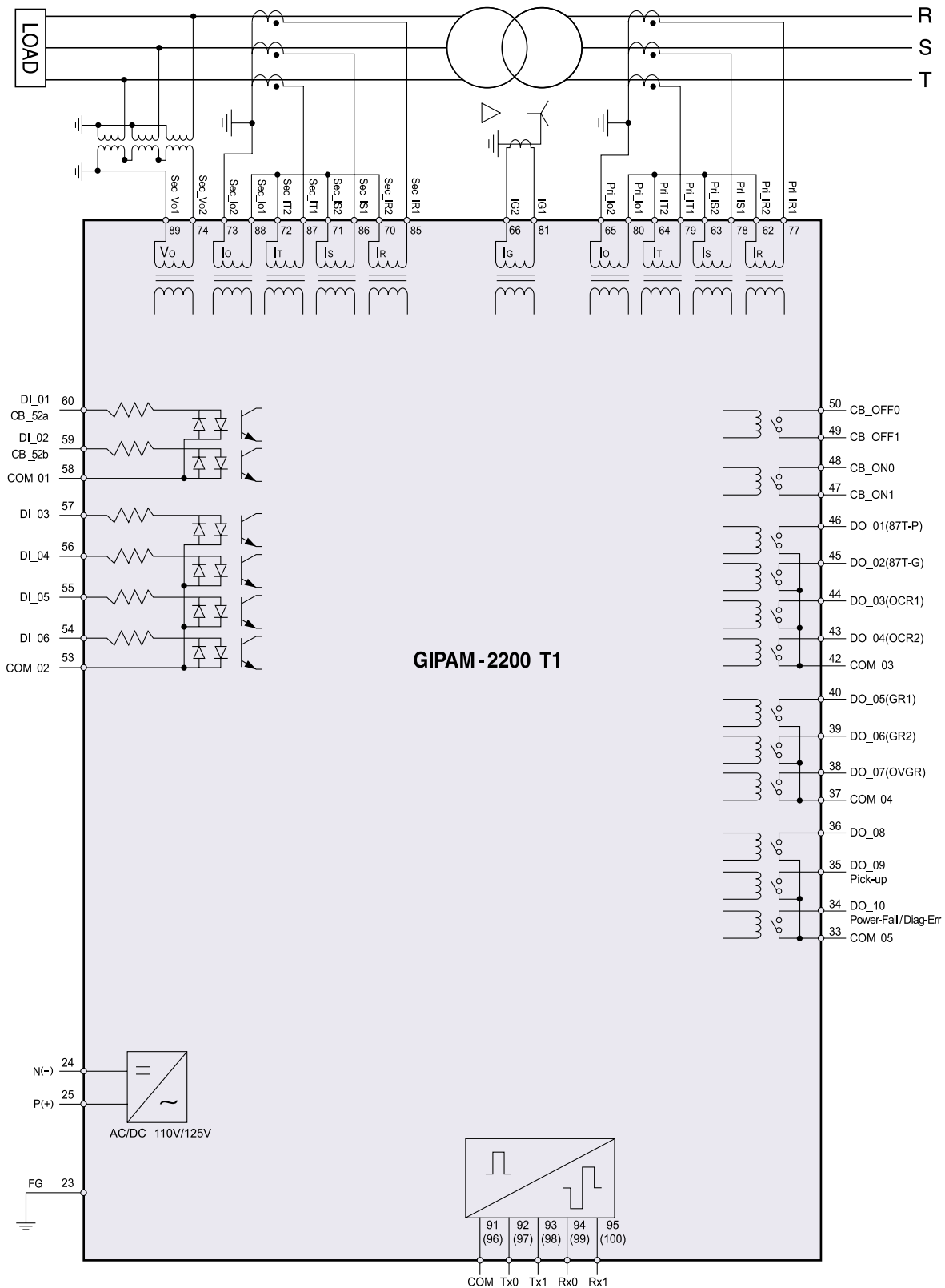

**N<sub>1</sub>**  
GIPAM-2000/2200

# Digital Integrated Protection & Monitoring Device

## Wirings

### GIPAM-2200 T2

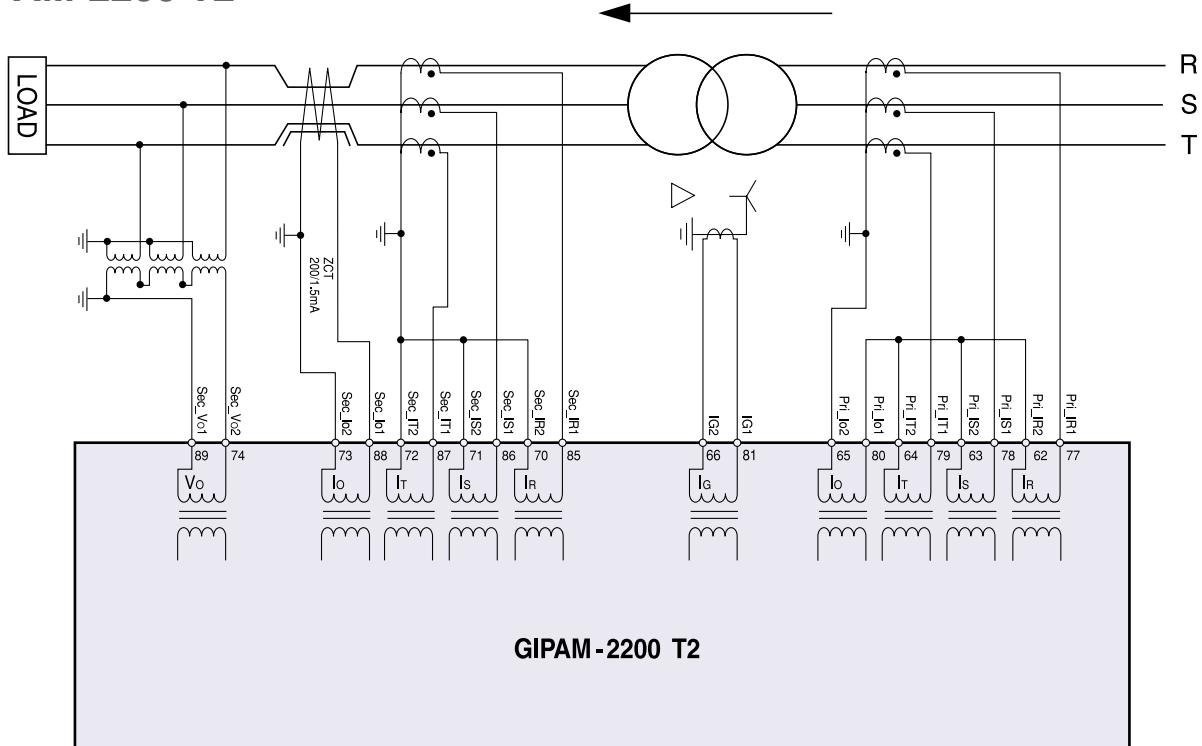

### GIPAM-2200 T3

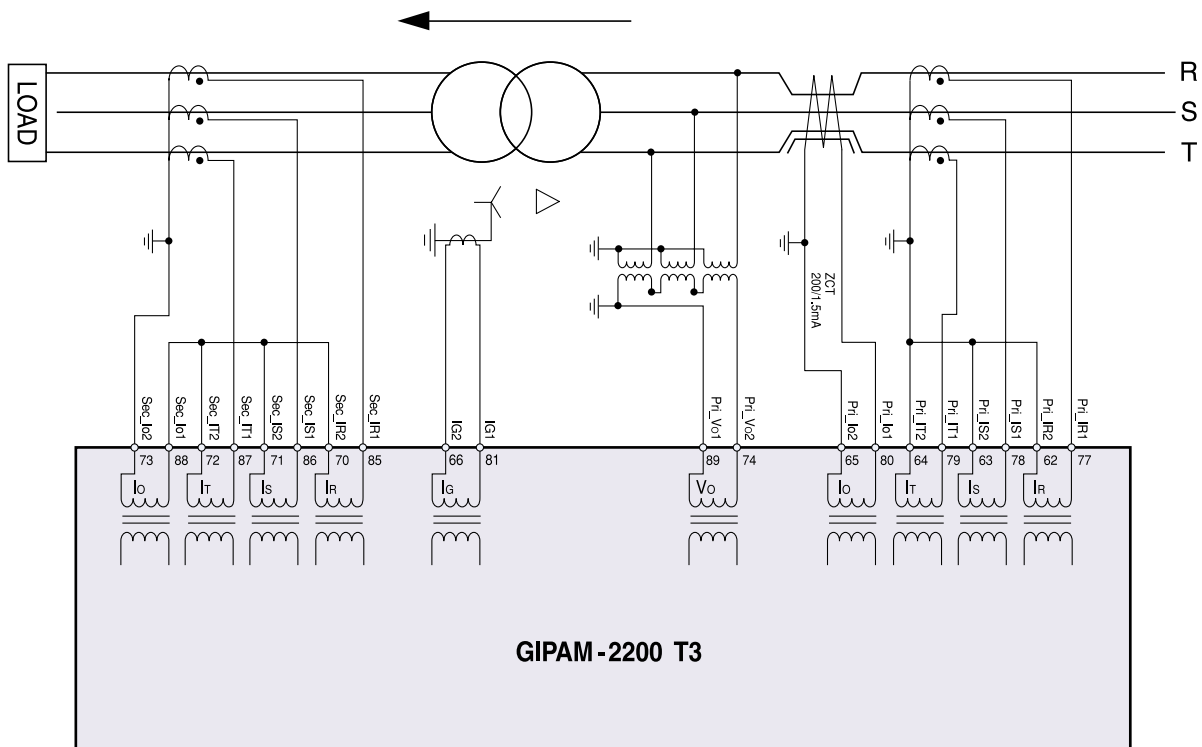

# Contact Usage

## GIPAM-2000FI/M

76	VR1	VR2	61
77	VS1	VS2	62
78	VT1	VT2	63
79	Vo1	Vo2	64
80	VB1	VB2	65
81	BLANK	BLANK	66
82	COM	COM	67
83	TX0	TX1	68
84	RX0	RX1	69
85	BLANK	BLANK	70
86	IR1	IR2	71
87	IS1	IS2	72
88	IT1	IT2	73
89	In1	In2	74
90	Io1	Io2	75

46	CB1_OFF0	CB1_OFF1	31
47	PO01+	PO01-	32
48	CB1_ON0	CB1_ON1	33
49	PO02+	PO02-	34
50	DO01	DO02	35
51	DO03	DO04	36
52	COM00	DO32	37
53	DO31	BLANK	38
54	ALM.COM	DO11	39
55	DO12	DO13	40
56	DO14	DO15	41
57	COM01	DO21	42
58	DO22	DO23	43
59	DO24	DO25	44
60	COM02	BLANK	45

16	DI02	DI01	1
17	DI04	DI03	2
18	DI11	COM00	3
19	DI13	DI12	4
20	COM01	DI14	5
21	DI22	DI21	6
22	DI24	DI23	7
23	DI31	COM02	8
24	DI33	DI32	9
25	DI35	DI34	10
26	DI37	DI36	11
27	COM03	DI38	12
28	BLANK	BLANK	13
29	POWER(-)	POWER(+)	14
30	FG	FG	15

## Input / Output

Terminal description	Terminal No.	Usage (default setting)	Usage (for change)	Remarks
DI01	1	CB1 status input (52a)	Unchangeable	
DI02	16	CB1 status input (52b)		
DI03	2	General DI	CB2 status input (52a)	Terminal No. Used as CB2 state input terminal when PO is set for TRIP in TRIP logic.
DI04	17	General DI	CB2 status input (52b)	
DI11	18	General DI	Input for 63CBI	Must be wired when selecting 79 (Reclosing)
DI12	4	General DI	Input for 43RC	
DI13	19	General DI	General DI	
DI14	5	General DI	Ext. Reclose Initiate output	79 sequence start at Logical High Input
DI21-DI38		General DI	General DI	Used as general Digital Input contact such as Switchgear Interlock Breaker Interlock, D / S state and E / S state,
CB1_OFF0	46	CB1 OFF output	Unchangeable	OVGR is not connected to the CB_OFF (TRIP circuit) . (Modify the LOGIC if necessary)
CB1_OFF1	31			
CB1_ON0	48	CB1 ON output	CB2 OFF output	Function as CB2 only when PO is set for TRIP in TRIP logic.
CB1_ON1	33			
PO01+	47	POWER OUT 1 output	CB2 ON output	
PO01 -	32			
PO02+	49	POWER OUT 2 output	CB2 OFF output	
PO02 -	34			
DO01	50	50/51 (OCR)	General DO	50/51 (OCR)
DO02	35	50/51N (OCGR)	General DO	50/51N (OCGR)
DO03	51	67G/N (SGR/DGR)	General DO	67G/N (SGR/DGR)
DO04	36	27 (UVR-Latch)	General DO	27 (UVR-Latch)
DO11	39	27R (R-UVR)	79 Ready	46 (NSOCR)
DO12	55	47P (POR)	79 Success	47P (POR)
DO13	40	47N (NSOVR)	79 Fail	47N (NSOVR)
DO14	56	General DO	79 Process	49 (THR)
DO15	41	General DO	79 Cancel	48/51LR
DO21	42	59 (OVR)	General DO	General DO
DO22	58	64 (OVGR)	General DO	General DO
DO23	43	27 (UVR-Pulse)	General DO	27 (UVR-Pulse)
DO24	59	86X (Lock-out)	General DO	86X (Lock-out)
DO25	44	BUZZER	General DO	BUZZER
DO31	53	DIAG_ERR	General DO	Terminal for self-diagnostic alarm
DO32	37	PWR_FAIL	General DO	Terminal for power supply problem alarm

\* M type output contacts (Default): can be used as General DO

# Digital Integrated Protection & Monitoring Device

## Contact Usage

### GIPAM-2000T

76	FG	FG	61
77	Pri_IR1	Pri_IR2	62
78	Pri_IS1	Pri_IS2	63
79	Pri_IT1	Pri_IT2	64
80	IN11	IN12	65
81	Sec_IR1	Sec_IR2	66
82	Sec_IS1	Sec_IS2	67
83	Sec_IT1	Sec_IT2	68
84	IN21	IN22	69
85	Ter_IR1	Ter_IR2	70
86	Ter_IS1	Ter_IS2	71
87	Ter_IT1	Ter_IT2	72
88	COM	COM	73
89	TX0	TX1	74
90	RX0	RX1	75

46	CB1_OFF0	CB1_OFF1	31
47	PO01+	PO01-	32
48	CB1_ON0	CB1_ON1	33
49	PO02+	PO02-	34
50	DO01	DO02	35
51	DO03	DO04	36
52	COM00	DO32	37
53	DO31	BLANK	38
54	ALM_COM	DO11	39
55	DO12	DO13	40
56	DO14	DO15	41
57	COM01	DO21	42
58	DO22	DO23	43
59	DO24	DO25	44
60	COM02	BLANK	45

16	DI02	DI01	1
17	DI04	DI03	2
18	DI11	COM00	3
19	DI13	DI12	4
20	COM01	DI14	5
21	DI22	DI21	6
22	DI24	DI23	7
23	DI31	COM02	8
24	DI33	DI32	9
25	DI35	DI34	10
26	DI37	DI36	11
27	COM03	DI38	12
28	BLANK	BLANK	13
29	POWER(-)	POWER(+)	14
30	FG	FG	15

Pri : Primary (for primary winding)  
 Sec : Secondary (for secondary winding)  
 Ter : Tertiary (for tertiary winding)

### Input / Output

Terminal description	Terminal No.	Usage (default setting)	Usage (for change)	Remarks
DI01	1	CB1 status input (52a)	Unchangeable	
DI02	16	CB1 status input (52b)		
DI03	2	General DI	CB2 status input (52a)	Terminal No. Used as CB2 state input terminal when PO is set for TRIP in TRIP logic
DI04	17	General DI	CB2 status input (52b)	
DI11-DI38		16 General DI	16 General DI	Used as general Digital Input contact such as Switchgear Interlock Breaker Interlock, D / S state and E / S state,
CB1_OFF0	46	CB1 OFF output	Unchangeable	
CB1_OFF1	31			
CB1_ON0	48	CB1 ON output		
CB1_ON1	33			
PO01+	47	POWER OUT 1 output	CB2 OFF output	Function as CB2 only when PO is set for TRIP
PO01 -	32			
PO02+	49	POWER OUT 2 output	CB2 ON output	
PO02 -	34			
DO01	50	OCR1 ALARM	General DO	
DO02	35	OCR2 ALARM	General DO	
DO03	51	OCR3 ALARM	General DO	
DO04	36	DFR ALARM	General DO	
DO11	39	General DO	General DO	
DO12	55	General DO	General DO	
DO13	40	OCGR1 ALARM	General DO	
DO14	56	OCGR2 ALARM	General DO	
DO15	41	General DO	General DO	
DO21	42	General DO	General DO	
DO22	58	General DO	General DO	
DO23	43	General DO	General DO	
DO24	59	86X (Lock-out)	General DO	
DO25	44	BUZZER	General DO	
DO31	53	DIAG_ERR	General DO	Terminal for self-diagnostic alarm
DO32	37	PWR_FAIL	General DO	Terminal for power supply problem alarm

# GIPAM-2200 FN/FZ

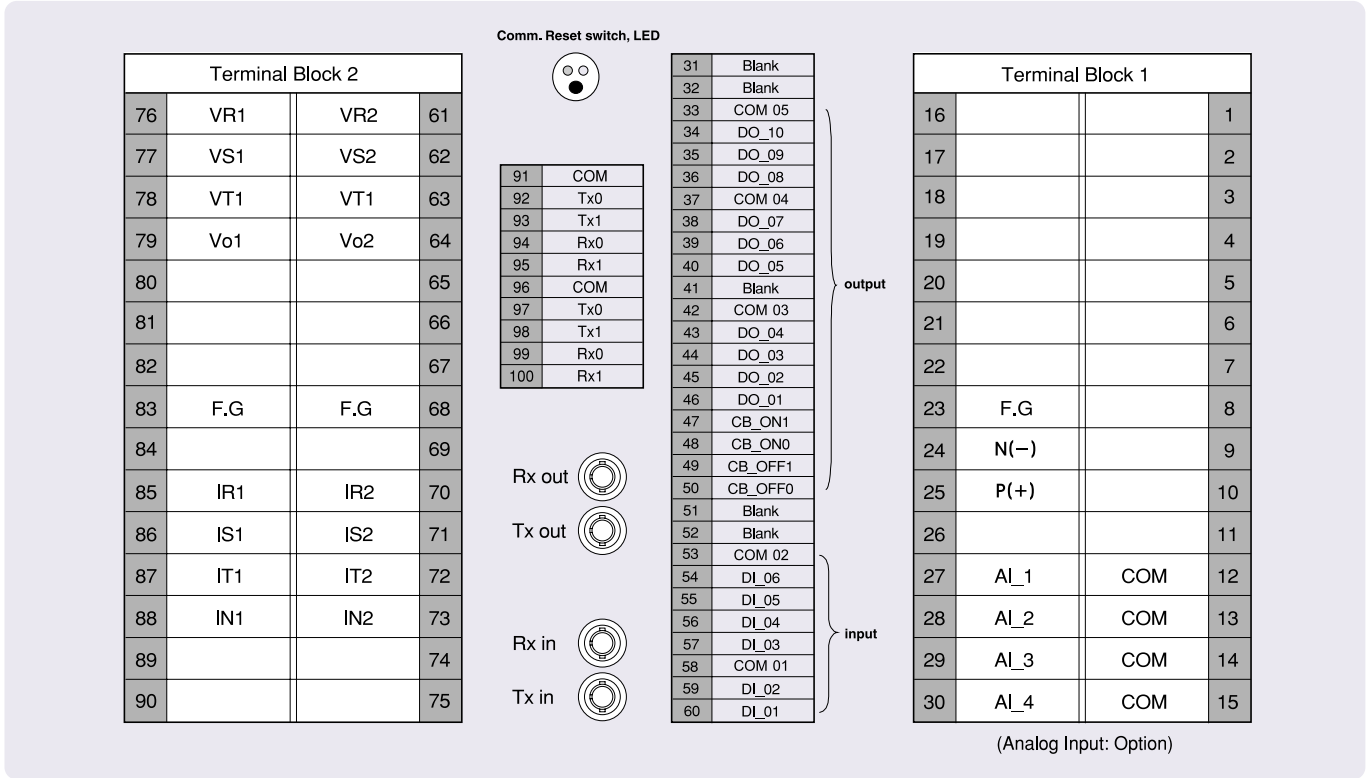

## Input / Output

Terminal No.	Usage	Default	Note
60	DI_01	CB_52a	Fixed
59	DI_02	CB_52b	
57	DI_03	General DI	General DI
56	DI_04	General DI	General DI
55	DI_05	General DI	General DI
54	DI_06	General DI	General DI
50	CB_OFF0	CB_OPEN output	Fixed
49	CB_OFF1		
48	CB_ON0	CB_CLOSE output	
47	CB_ON1		
46	DO_01	50/51 (OCR)	General DO (Normal/Pulse)
45	DO_02	50/51N, 67G/N (OCGR/SGR/DGR)	General DO (Normal/Pulse)
44	DO_03	27 (UVR)	General DO (Normal/Pulse)
43	DO_04	59 (OVR)	General DO (Normal/Pulse)
40	DO_05	64 (OVGR)*	General DO (Normal/Pulse)
39	DO_06	47 (NSOVR)	General DO (Normal/Pulse)
38	DO_07	49 (THR)	General DO (Normal/Pulse)
36	DO_08	48/51LR (Stall/Lock)	General DO (Normal/Pulse)
35	DO_09	Pick-up	Fixed
34	DO_10	Power_Fail/Diag_Err	

\* OVGR is not connected to the CB\_OFF. ( Modify the LOGIC if necessary )

# Digital Integrated Protection & Monitoring Device

## Contact Usage

### GIPAM-2200 T

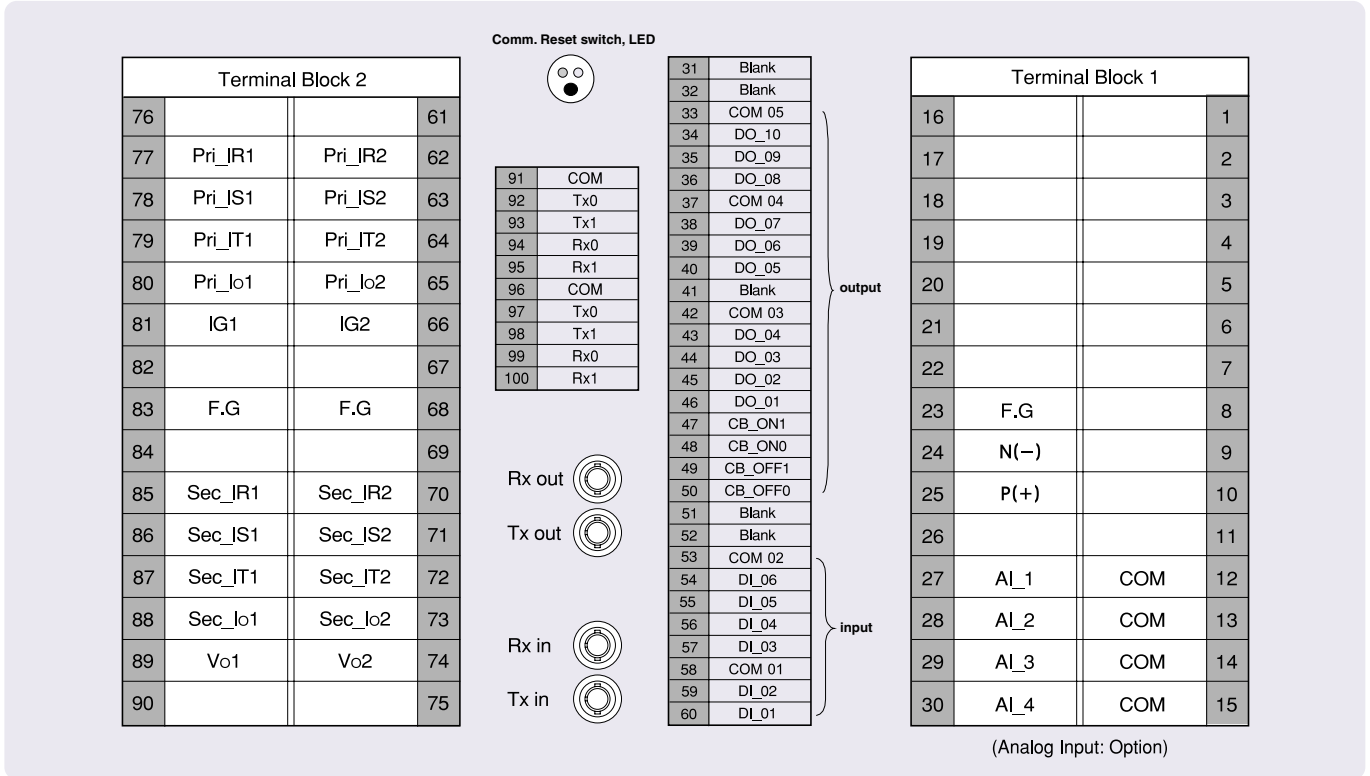

### Input / Output

Terminal No.	Usage	Default	Note
60	DI_01	CB_52a	Fixed
59	DI_02	CB_52b	
57	DI_03	General DI	General DI
56	DI_04	General DI	General DI
55	DI_05	General DI	General DI
54	DI_06	General DI	General DI
50	CB_OFF0	CB_OPEN output	Fixed
49	CB_OFF1		
48	CB_ON0	CB_CLOSE output	
47	CB_ON1		
46	DO_01	87T-P (DFR)	General DO (Normal/Pulse)
45	DO_02	87T-G (DFR)	General DO (Normal/Pulse)
44	DO_03	50/51 (OCR 1)	General DO (Normal/Pulse)
43	DO_04	50/51 (OCR 2)	General DO (Normal/Pulse)
40	DO_05	50/51N, 67G/N (OCGR/SGR/DGR 1)	General DO (Normal/Pulse)
39	DO_06	50/51N, 67G/N (OCGR/SGR/DGR 2)	General DO (Normal/Pulse)
38	DO_07	64 (OVGR)*	General DO (Normal/Pulse)
36	DO_08	General DO (Normal)	General DO (Normal/Pulse)
35	DO_09	Pick-up	Fixed
34	DO_10	Power_Fail/Diag_Err	

\* OVGR is not connected to the CB\_OFF. ( Modify the LOGIC if necessary )

# Dimension

## GIPAM-2000

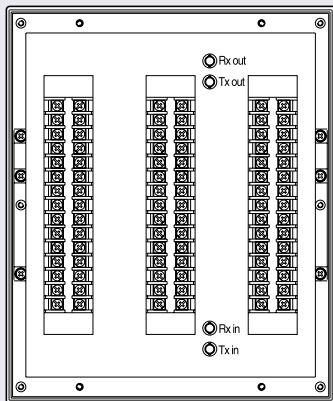
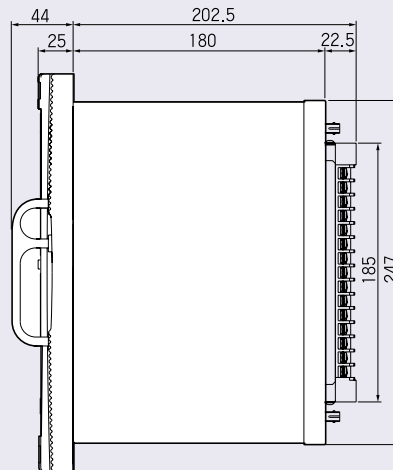
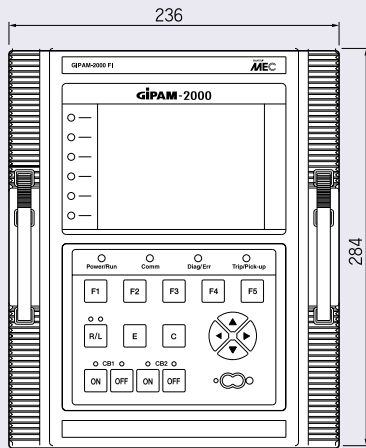
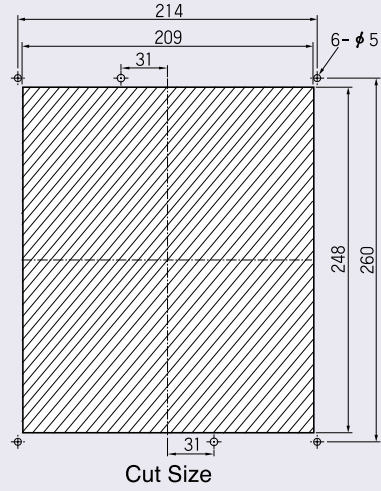
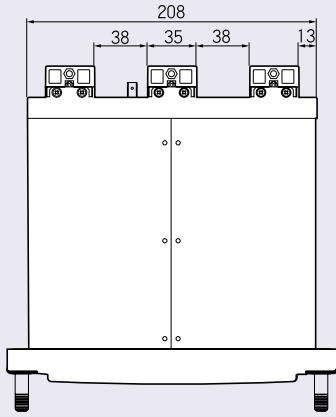

# Digital Integrated Protection & Monitoring Device

## Dimension

### GIPAM-2200

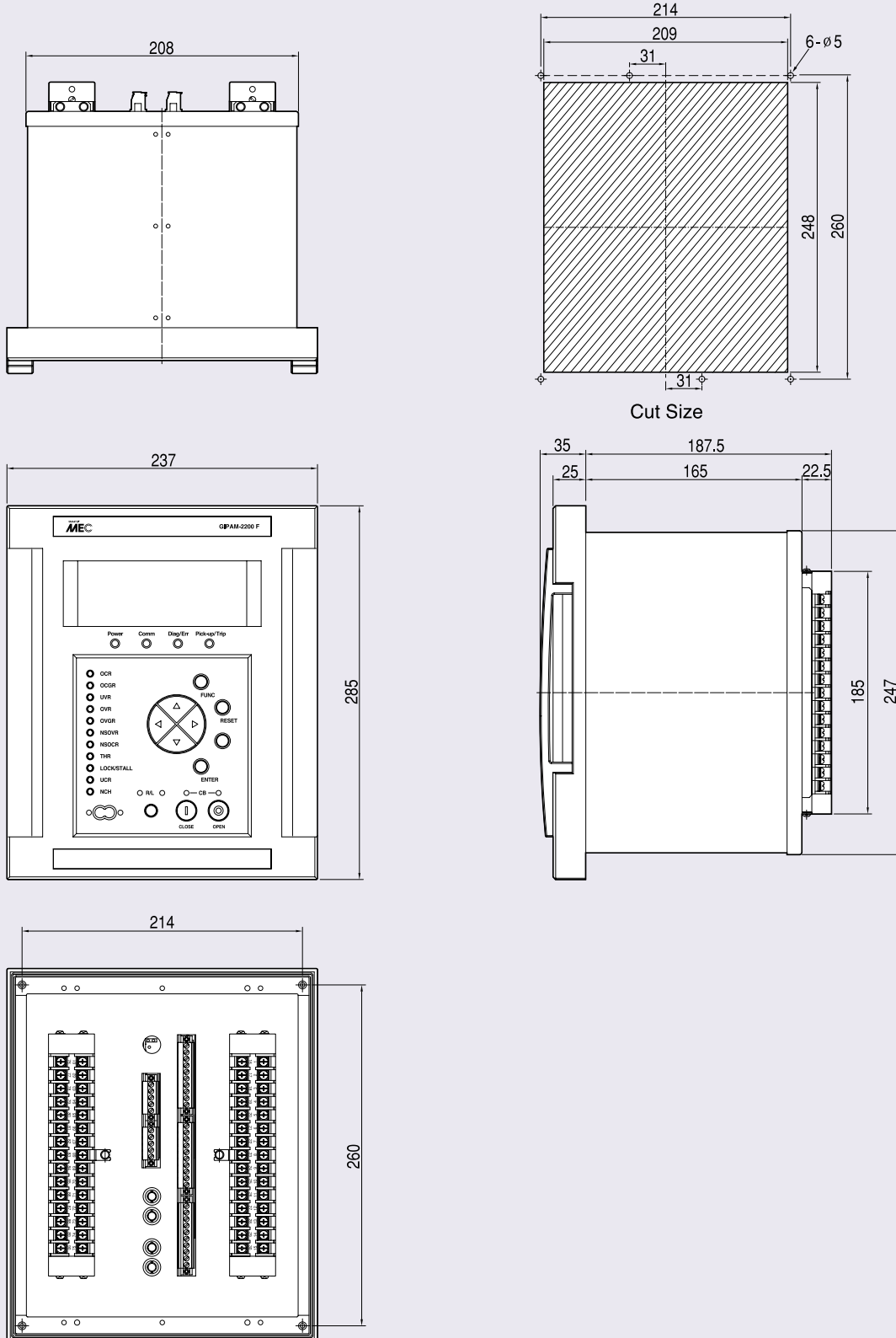

# Ordering

## GIPAM - 2000

Protection Usage		Communication		Protocol		Frequency		Input	
<b>FI</b>	Feeder/Incoming	<b>RS</b>	RS-485	<b>D</b>	DNP3.0	60Hz		5A	
<b>M</b>	Motor	<b>OP</b>	Fiber-Optic/RS-485	<b>M</b>	MODBUS	50Hz		1A*	
<b>T</b>	Transformer	<b>IN</b>	I-NET	<b>I</b>	I-NET				
		<b>TE</b>	100/10 Base-T Ethernet						
		-	Non						

## GIPAM-2200

Protection Usage		Communication		Protocol		Analog Input		Frequency	
<b>FN</b>	Feeder, Incoming, Motor / NCT	<b>RS</b>	RS-485	<b>D</b>	DNP3.0	<b>AI</b>	4~20mA	60Hz	
<b>FZ</b>	Feeder, Incoming, Motor / ZCT	<b>OP</b>	Fiber-Optic/RS-485	<b>E</b>	IEC60870	-	Non	50Hz	
<b>T1</b>	Transformer / Pri_NCT, Sec_NCT	<b>IN</b>	I-NET	<b>M</b>	MODBUS				
<b>T2</b>	Transformer / Pri_NCT, Sec_ZCT	-	Non	<b>I</b>	I-NET				
<b>T3</b>	Transformer / Pri_ZCT, Sec_NCT								

## GIPAM-OPTO MASTER —

IrDA Serial Port(Optional)  
PC Interface Software

\* Contact your LS sales representative for 1A specification.